

Department of Mechanical Engineering

Department of Mechanical Engineering

Course File

COMPUTER AIDED ENGINEERING GRAPHICS
(Course Code: EG203ES)

I B.Tech II Semester

2023-24

Mr.L.RAMESH
Assistant Professor



Anurag
ENGINEERING COLLEGE
(An Autonomous Institution)
Ananthagiri, Kodad, Telangana 508 206, India.

Department of Mechanical Engineering

COMPUTER AIDED ENGINEERING GRAPHICS

Check List

S.No	Name of the Format	Page No.
1	Syllabus	3
2	Timetable	4
3	Program Educational Objectives	6
4	Program Objectives	6
5	Course Objectives	7
6	Course Outcomes	7
7	Guidelines to study the course	8
8	Course Schedule	9
9	Course Plan	12
10	Unit Plan	12
11	Lesson Plan	12
12	Assignment Sheets	16
13	Tutorial Sheets	21
14	Evaluation Strategy	26
15	Assessment in relation to COb's and CO's	28
16	Mappings of CO's and PO's	28
17	Rubric for course	29
18	Mid-I and Mid-II question papers	30
19	Mid-I mark	32
20	Mid-II mark	33
21	Sample answer scripts and Assignments	36
22	Course materials like Notes, PPT's, etc.	37

Department of Mechanical Engineering

Int. Marks: 40 Ext. Marks: 60 Total Marks: 100

B.Tech ME I Year II-Semester

L T P C
1 4 0 3

(EG203ES)COMPUTER AIDED ENGINEERING GRAPHICS

UNIT – I: Introduction to Engineering Graphics: Principles of Engineering Graphics and their Significance, Scales – Plain & Diagonal, Conic Sections including the Rectangular Hyperbola – General method only. Cycloid, Epicycloid and Hypocycloid, Introduction to Computer aided drafting – views, commands and conics

UNIT- II: Orthographic Projections: Principles of Orthographic Projections – Conventions – Projections of Points and Lines, Projections of Plane regular geometric figures. Computer aided orthographic projections – points, lines and planes

UNIT – III: Projections of Regular Solids Sections or Sectional views of Right Regular Solids – Prism, Cylinder, Pyramid, Cone, and Computer aided projections of solids – sectional views

UNIT – IV: Development of Surfaces of Right Regular Solids – Prism, Cylinder, Pyramid and Cone, Development of surfaces using computer aided drafting

UNIT – V: Isometric Projections: Principles of Isometric Projection – Isometric Scale – Isometric Views – Conventions – Isometric Views of Lines, Plane Figures, Simple and Compound Solids – Isometric Projection of objects having non- isometric lines. Isometric Projection of Spherical Parts. Conversion of Isometric Views to Orthographic Views and Vice-versa –Conventions. Conversion of orthographic projection into isometric view using computer aided drafting.

Text Book:

1. Engineering Drawing N.D. Bhatt / Charotar
2. Engineering Drawing and graphics Using AutoCAD Third Edition, T. Jeyapoovan, Vikas: S. Chand and company Ltd.2009.

References:

1. Engineering Drawing, Basant Agrawal and C M Agrawal, Third Edition McGraw Hill
2. Engineering Graphics and Design, WILEY, Edition 2020.
3. Engineering Drawing, M. B. Shah, B.C. Rane / Pearson.
4. Engineering Drawing, N. S. Parthasarathy and Vela Murali, Oxford
5. Computer Aided Engineering Drawing – K Balaveera Reddy et al – CBS Publishers.

Department of Mechanical Engineering

Timetable

I B.Tech. II Semester – CAEG

Day/Hour	9.30-10.20	10.2-11.10	11.20-12.10	12.10-1.00	1.35-2.25	2.25-3.10	3.15-4.00
Monday							
Tuesday							
Wednesday							
Thursday							
Friday	CAEG						
Saturday					CAEG		

Department of Mechanical Engineering

Vision of the Institute

To be a premier Institute in the country and region for the study of Engineering, Technology and Management by maintaining high academic standards which promotes the analytical thinking and independent judgment among the prime stakeholders, enabling them to function responsibly in the globalized society.

Mission of the Institute

To be a world-class Institute, achieving excellence in teaching, research and consultancy in cutting-edge Technologies and be in the service of society in promoting continued education in Engineering, Technology and Management.

Quality Policy

To ensure high standards in imparting professional education by providing world-class infrastructure, top-quality-faculty and decent work culture to sculpt the students into Socially Responsible Professionals through creative team-work, innovation and research

Vision of the Department

To equip the Mechanical Engineering students with the best analytical skills in the state of the latest technologies and the best communication skills to meet the Mechanical Engineering manpower requirement both nationally and internationally to responds to the demands of the market which are dynamic in nature.

Mission of the Department

To equip the Mechanical Engineering students with the best analytical skills in the state of the latest technologies and the best communication skills to meet the Mechanical Engineering manpower requirement both nationally and internationally to responds to the demands of the market which are dynamic in nature.

Department of Mechanical Engineering

Program Educational Objectives (B.Tech. – ME)

Graduates will be able to

- PEO 1: To transcend in a professional career by acquiring knowledge in basic sciences, mathematics and mechanical engineering.
- PEO 2: To exhibit problem solving skills on par with global requirements in industry and R&D.
- PEO 3: To adopt the latest technologies, evolve as entrepreneurs, solving mechanical engineering problems, dealing with environmental society and ethical issues.

Program Outcomes (B.Tech. – ME)

At the end of the Program, a graduate will have the ability to

- PO 1: An ability to apply the knowledge of mathematics, science and engineering fundamentals.
- PO 2: An ability to conduct Investigations using design of experiments, analysis and interpretation of data to arrive at valid conclusions.
- PO 3: An ability to design mechanical engineering components and processes within economic, environmental, ethical and manufacturing constraints.
- PO 4: An ability to function effectively in multidisciplinary teams.
- PO 5: An ability to identify, formulate, analyze and solve Mechanical Engineering problems.
- PO 6: An ability to understand professional, ethical and social responsibility.
- PO 7: An ability to communicate effectively through written reports or oral presentations.
- PO 8: The broad education necessary to understand the impact of engineering solutions in a global, economic, environmental, and societal context.
- PO 9: An ability to recognize the need and to engage in independent and life-long learning.
- PO 10: A knowledge of contemporary issues.
- PO 11: An ability to use the appropriate techniques and modern engineering tools necessary for engineering practice.
- PO 12: An ability to demonstrate knowledge and understanding of engineering.

Department of Mechanical Engineering

COURSE OBJECTIVES

On completion of this Subject/Course the student shall be able to:

S.No	Objectives
1	To develop the ability of visualization of different objects through technical drawings.
2	To impart knowledge about standard principles of orthographic projection of objects
3	To draw the regular solids and sectional views of the objects.
4	To development the right regular solids surfaces of solids.
5	To draw Isometric views and modern engineering tools like Auto Cad software necessary for engineering practice

COURSE OUTCOMES

The expected outcomes of the Course/Subject are:

S.No	Outcomes
1	Apply computer aided drafting tools to create 2D and 3D objects.
2	Visualize the different aspects of Points, Lines and Planes.
3	Acquire knowledge on projections of solids.
4	Draw the Sectional views of solids and plan the drawing for development of surfaces.
5	Understand the isometric views and projections. Exposure to computer-aided geometric design and creating working drawings



Signature of faculty

Note: Please refer to Bloom's Taxonomy, to know the illustrative verbs that can be used to state the outcomes.

Department of Mechanical Engineering**GUIDELINES TO STUDY THE COURSE / SUBJECT****Course Design and Delivery System (CDD):**

- The Course syllabus is written into number of learning objectives and outcomes.
- Every student will be given an assessment plan, criteria for assessment, scheme of evaluation and grading method.
- The Learning Process will be carried out through assessments of Knowledge, Skills and Attitude by various methods and the students will be given guidance to refer to the text books, reference books, journals, etc.

The faculty be able to –

- Understand the principles of Learning
- Understand the psychology of students
- Develop instructional objectives for a given topic
- Prepare course, unit and lesson plans
- Understand different methods of teaching and learning
- Use appropriate teaching and learning aids
- Plan and deliver lectures effectively
- Provide feedback to students using various methods of Assessments and tools of Evaluation
- Act as a guide, advisor, counselor, facilitator, motivator and not just as a teacher alone



Signature of HOD

Date:

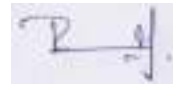

Signature of faculty

Date:

Department of Mechanical Engineering

COURSE SCHEDULE

The Schedule for the whole Course / Subject is:

S. No.	Description	Duration (Date)		Total No. of Periods
		From	To	
1.	UNIT – I: Introduction to Engineering Graphics: Principles of Engineering Graphics and their Significance, Scales – Plain & Diagonal, Conic Sections including the Rectangular Hyperbola – General method only. Cycloid, Epicycloid and Hypocycloid, Introduction to Computer aided drafting – views, commands and conics	09.02.2024	24.02.2024	15
2.	UNIT- II: Orthographic Projections: Principles of Orthographic Projections – Conventions – Projections of Points and Lines, Projections of Plane regular geometric figures. Computer aided orthographic projections – points, lines and planes	01.03.2024	16.03.2024	12
3.	UNIT – III: Projections of Regular Solids Sections or Sectional views of Right Regular Solids – Prism, Cylinder, Pyramid, Cone, and Computer aided projections of solids – sectional views	22.03.2024	20.04.2024	15
4.	UNIT – IV: Development of Surfaces of Right Regular Solids – Prism, Cylinder, Pyramid and Cone, Development of surfaces using computer aided drafting	26.04.2024	04.05.2024	12
5.	UNIT – V: Isometric Projections: Principles of Isometric Projection – Isometric Scale – Isometric Views – Conventions – Isometric Views of Lines, Plane Figures, Simple and Compound Solids – Isometric Projection of objects having non- isometric lines. Isometric Projection of Spherical Parts. Conversion of Isometric Views to Orthographic Views and Vice-versa –Conventions. Conversion of orthographic projection into isometric view using computer aided drafting.	10.05.2024	07.06.2024	12

Total No. of Instructional periods available for the course: 73 Hours

Department of Mechanical Engineering

SCHEDULE OF INSTRUCTIONS - COURSE PLAN

Unit No.	Lesson No.	Date	No. of Periods	Topics / Sub-Topics	Objectives & Outcomes Nos.	References (Textbook, Journal)
1.	1	09.02.2024	3	UNIT-1 Introduction to Engineering Drawing- Principles of Engineering Graphics	1 1	Engineering Drawing N.D. Bhatt / Charotar
	2	16.02.2024	3	Geometrical Constructions	1 1	Engineering Drawing N.D. Bhatt / Charotar
	3	17.02.2024	3	Conic sections Ellipse, Parabola , Hyperbola	1 1	Engineering Drawing N.D. Bhatt / Charotar
	4	23.02.2024	3	Rectangular hyperbola ,Cycloid and Epicycloid	1 1	Engineering Drawing N.D. Bhatt / Charotar
	5	24.02.2024	3	Hypocycloid and Scales	1 1	Engineering Drawing N.D. Bhatt / Charotar
2.	1	01.03.2024	3	UNIT-2 Orthographic Projections and projection of points	2 2	Engineering Drawing N.D. Bhatt / Charotar
	2	02.03.2024	3	Projections of lines	2 2	Engineering Drawing N.D. Bhatt / Charotar
	3	15.03.2024	3	Projections of Planes-I&II	2 2	Engineering Drawing N.D. Bhatt / Charotar
	4	16.03.2024	3	Projections of Planes-III	2 2	Engineering Drawing N.D. Bhatt / Charotar
3.	1	22.03.2024	3	UNIT-3 Projections of Regular Solids	3 3	Engineering Drawing N.D. Bhatt / Charotar
	2	23.03.2024	3	Projections of Regular Solids	3 3	Engineering Drawing N.D. Bhatt / Charotar
	3	30.03.2024	3	Projections of Regular Solids	3 3	Engineering Drawing N.D. Bhatt / Charotar
	4	19.04.2024	3	Sections of Solids	3 3	Engineering Drawing N.D. Bhatt / Charotar
	5	20.04.2024	3	Sections of Solids	3 3	Engineering Drawing N.D. Bhatt / Charotar
4	1	26.04.2024	3	UNIT-4 Development of surfaces of Right Regular Solids	4 4	Engineering Drawing N.D. Bhatt / Charotar
	2	27.04.2024	3	Traingulation Line Method	4 4	Engineering Drawing N.D. Bhatt / Charotar
	3	03.05.2024	3	Parallel Line Method-Problems	4 4	Engineering Drawing N.D. Bhatt / Charotar
	4	04.05.2024	3	Radial Line Method-Problems	4 4	Engineering Drawing N.D. Bhatt / Charotar
5	1	10.05.2024	3	UNIT-5 Isometric Projections- Principles of Isometric Projection	5 5	Engineering Drawing N.D. Bhatt / Charotar

Department of Mechanical Engineering

	2	17.05.2024	3	Isometric Projections-Pyramid and cone	5 5	Engineering Drawing N.D. Bhatt / Charotar
	3	18.05.2024	3	Conversion of Isometric Views to Orthographic Views and Vice-versa	5 5	Engineering Drawing N.D. Bhatt / Charotar
	4	07.06.2024	3	Practice	5 5	Engineering Drawing N.D. Bhatt / Charotar



Signature of HOD

Date:

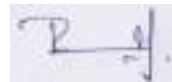

Signature of faculty

Date:

Department of Mechanical Engineering



ANURAG Engineering College

(An Autonomous Institution)

(Approved by AICTE, New Delhi, Affiliated to JNTUH, Hyderabad)

Ananthagiri (V&M), Kodad, Suryapet (Dt), Pin: 508 206.

DEPARTMENT OF HUMANITIES AND SCIENCES
A.Y. 2023-24 (Even Semester)
I B.Tech II Semester Teaching Plan

Branch/Section:		IT		Commence of Classwork: 05-02-2024	
Name of the Faculty:		L.RAMESH			
SUBJECT:		CAEG			
Date	Day	Week No	Classes per week	Topics to be covered	Topic covered Date
5-Feb-24	MON	1	3		
6-Feb-24	TUE				
7-Feb-24	WED				
8-Feb-24	THU				
9-Feb-24	FRI			UNIT-1 Introduction to Engineering Drawing-Principles of Engineering Graphics	
10-Feb-24	SAT	Second Saturday			
11-Feb-24	SUN	SUNDAY			
12-Feb-24	MON	2	6		
13-Feb-24	TUE				
14-Feb-24	WED				
15-Feb-24	THU				
16-Feb-24	FRI			GEOMETRICAL CONSTRUCTIONS	
17-Feb-24	SAT	Conic sections Ellipse, Parabola, Hyperbola			
18-Feb-24	SUN	SUNDAY			
19-Feb-24	MON	3	6		
20-Feb-24	TUE				
21-Feb-24	WED				
22-Feb-24	THU				
23-Feb-24	FRI			Rectangular hyperbola, Cycloid and Epicycloid	

Department of Mechanical Engineering

24-Feb-24	SAT			Hypocycloid and Scales		
25-Feb-24	SUN	SUNDAY				
26-Feb-24	MON	4	6			
27-Feb-24	TUE					
28-Feb-24	WED					
29-Feb-24	THU					
1-Mar-24	FRI			UNIT-2 Orthographic Projections and projection of points		
2-Mar-24	SAT			Projections of lines		
3-Mar-24	SUN	SUNDAY				
4-Mar-24	MON	5	0			
5-Mar-24	TUE					
6-Mar-24	WED					
7-Mar-24	THU					
8-Mar-24	FRI			Maha Shivaratri		
9-Mar-24	SAT			Second Saturday		
10-Mar-24	SUN	SUNDAY				
11-Mar-24	MON	6	6			
12-Mar-24	TUE					
13-Mar-24	WED					
14-Mar-24	THU					
15-Mar-24	FRI			Projections of Planes		
16-Mar-24	SAT			Projections of Planes		
17-Mar-24	SUN	SUNDAY				
18-Mar-24	MON	7	6			
19-Mar-24	TUE					
20-Mar-24	WED					
21-Mar-24	THU					
22-Mar-24	FRI			UNIT-3 Projections of Regular Solids		
23-Mar-24	SAT			Projections of Regular Solids		
24-Mar-24	SUN	SUNDAY				
25-Mar-24	MON	8	3	Holi		
26-Mar-24	TUE					
27-Mar-24	WED					
28-Mar-24	THU					
29-Mar-24	FRI			Good Friday		

Department of Mechanical Engineering

30-Mar-24	SAT			Projections of Regular Solids		
31-Mar-24	SUN	SUNDAY				
1-Apr-24	MON	9	0	I Mid Examinations		
2-Apr-24	TUE			I Mid Examinations		
3-Apr-24	WED			I Mid Examinations		
4-Apr-24	THU					
5-Apr-24	FRI			Babu Jagjivan Ram Jayanthi		
6-Apr-24	SAT			Sectional views of Right Regular solids		
7-Apr-24	SUN			SUNDAY		
8-Apr-24	MON	10	0			
9-Apr-24	TUE			Ugadi		
10-Apr-24	WED					
11-Apr-24	THU			Ramzan		
12-Apr-24	FRI			Ramzan		
13-Apr-24	SAT			Second Saturday		
14-Apr-24	SUN			SUNDAY		
15-Apr-24	MON	11	6			
16-Apr-24	TUE					
17-Apr-24	WED			Ram Navami		
18-Apr-24	THU					
19-Apr-24	FRI			Sections of Solids		
20-Apr-24	SAT			Sections of Solids		
21-Apr-24	SUN			SUNDAY		
22-Apr-24	MON	12	6			
23-Apr-24	TUE					
24-Apr-24	WED					
25-Apr-24	THU					
26-Apr-24	FRI			UNIT-4 Development of surfaces of Right Regular Solids		
27-Apr-24	SAT			Traingulation Line Method		
28-Apr-24	SUN			SUNDAY		
29-Apr-24	MON	13	6			
30-Apr-24	TUE					
1-May-24	WED					
2-May-24	THU					
3-May-24	FRI			Parallel Line Method-Problems		

Department of Mechanical Engineering

4-May-24	SAT			Radial Line Method-Problems	
5-May-24	SUN	SUNDAY			
6-May-24	MON	14	3		
7-May-24	TUE				
8-May-24	WED				
9-May-24	THU				
10-May-24	FRI			UNIT-5 Isometric Projections-Principles of Isometric Projection	
11-May-24	SAT			Second Saturday	
12-May-24	SUN	SUNDAY			
13-May-24	MON	15	6		
14-May-24	TUE				
15-May-24	WED				
16-May-24	THU				
17-May-24	FRI			Isometric Projections-Pyramid and cone	
18-May-24	SAT			Conversion of Isometric Views to Orthographic Views and Vice-versa	
19-May-24	SUN	SUNDAY			
20-May-24	MON	16	0		
21-May-24	TUE				
22-May-24	WED				
23-May-24	to 05-06-2024	Summer vacation			
6-Jun-24	THU	17	3		
7-Jun-24	FRI			Conversion of Isometric Views to Orthographic Views and Vice-versa	
8-Jun-24	SAT			Second Saturday	
9-Jun-24	SUN	SUNDAY			
10-Jun-24	MON	18	0		
11-Jun-24	TUE				
12-Jun-24	WED				
13-06-2024 to 15-06-2024				II Mid Examinations	
18-06-2024 to 24-06-2024				PREPARATION & PRACTICAL EXAMINATIONS	
25-06-2024 to 20.07.2024				END SEMESTER EXAMINATIONS	



Signature of HOD

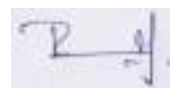

Signature of faculty

Department of Mechanical Engineering

ASSIGNMENT – 1

This Assignment corresponds to Unit No. 1

Question No.	Question	Objective No.	Outcome No.
1	Construct an ellipse, with distance of the focus from the directrix as 50 mm and eccentricity as $2/3$. also draw normal and tangent to the curve at a point 40 mm from the directrix.	1	1
2	A circle of 50 mm diameter rolls along a line for one revolution clockwise. Draw a locus of a point on the circle, which is in contact with the line.	1	1
3	Construct a parabola, with distance of the focus from the directrix as 60 mm. also draw normal and tangent to the curve at a point 70 mm from the focus.	1	1



Signature of HOD

Date:

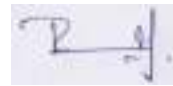

Signature of faculty

Date:

Department of Mechanical Engineering

ASSIGNMENT – 2

This Assignment corresponds to Unit No. 2

Question No.	Question	Objective No.	Outcome No.
1	A line AB measures 100mm is inclined at an angle of 30° to HP and 40° to VP. The point A is 20mm above HP and 30mm in front of VP. Draw the projections of the line.	2	2
2	A semi-circular lamina of 60mm diameter has its straight edge in VP and inclined at an angle of 45° to HP. The surface of the lamina makes an angle of 30° with VP. Draw the projections.	2	2
3	A Hexagonal plane of side 30mm its straight edge in HP and inclined at an angle of 45° to HP. The surface of the lamina makes an angle of 30° with VP. Draw the projections.	2	2



Signature of HOD

Date:

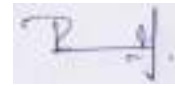

Signature of faculty

Date:

Department of Mechanical Engineering

ASSIGNMENT – 3

This Assignment corresponds to Unit No. 3

Question No.	Question	Objective No.	Outcome No.
1	A square prism side of base 30 mm and axis 50 mm long has its axis inclined at 45° to the H.P. It has an edge of its base in the H.P. Draw its projections.	3	3
2	A hexagonal prism side of base 35 mm and axis 60 mm long has its axis inclined at 45° to the H.P. It has an edge of its base in the H.P. Draw its projections.	3	3
3	A pentagonal pyramid side of base 35 mm and axis 60 mm long has its axis inclined at 45° to the H.P. It has an edge of its base in the H.P. Draw its projections.	3	3



Signature of HOD

Date:

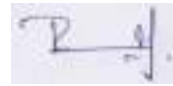

Signature of faculty

Date:

Department of Mechanical Engineering

ASSIGNMENT – 4

This Assignment corresponds to Unit No. 4

Question No.	Question	Objective No.	Outcome No.
1	A hexagonal prism edge of base 30mm and axis 70mm long, rest with its corner on the HP such that one of its rectangular face is parallel to VP. It is cut by a plane perpendicular to the VP, inclined at 45° to HP and passing through the 30mm from the base of axis. Draw the development of lateral surface of the truncated prism.	4	4
2	A cone of base diameter is 50mm and axis 60mm long is resting with its base on HP. It is cut by a section plane perpendicular to the VP and inclined at 45° to the HP and bisecting axis. Draw the development.	4	4
3	A pentagonal pyramid edge of base 30mm and axis 70mm long, rest with its corner on the HP such that one of its rectangular face is parallel to VP. It is cut by a plane perpendicular to the VP, inclined at 45° to HP and passing through the 30mm from the base of axis. Draw the development of lateral surface of the truncated prism.	4	4



Signature of HOD

Date:

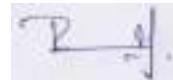

Signature of faculty

Date:

Department of Mechanical Engineering
ASSIGNMENT – 5

This Assignment corresponds to Unit No. 5

Question No.	Question	Objective No.	Outcome No.
1	Draw an isometric view of a Cylinder of base diameter 40mm and axis 60mm long, in the following position. (i) Vertical. (ii) Horizontal.	4	4
2	Draw an isometric projection of a hexagonal prism of side of base 25mm and axis 65mm long, in the following position. (i) Vertical. (ii) Horizontal.	4	4
3	Draw an isometric projection of a pentagonal pyramid of side of base 25mm and axis 65mm long, in the following position. (i) Vertical. (ii) Horizontal.	4	4



Signature of HOD

Date:

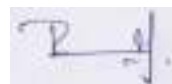

Signature of faculty

Date:

Department of Mechanical Engineering

TUTORIAL – 1

This tutorial corresponds to Unit No. 2 (Objective Nos.: 1, Outcome Nos.: 1)

1. The angle between the asymptotes of a rectangular hyperbola is
 - a) 30°
 - b) 45°
 - c) 60°
 - d) 90°
2. Eccentricity for an Ellipse?
 - a) Less than 1
 - b) Equal to 1
 - c) Greater than 1
 - d) None of the above
3. Application of cycloids is to produce
 - a) Gear Teeth
 - b) sprocket
 - c) Caliper
 - d) Compass



Signature of HOD

Date:

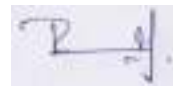

Signature of faculty

Date:

Department of Mechanical Engineering**TUTORIAL – 2**

This tutorial corresponds to Unit No. 1 (Objective Nos.: 2, Outcome Nos.: 2)

1. The line joining the front and top views of a point is called?

- a) reference line
- b) projector
- c) connector
- d) locus

2. If a line is parallel to both H.P and V.P., its true length will be seen in

- a) front view
- b) top view
- c) Side view
- d) Both front and top views

3. A hexagon is placed parallel to vertical plane which of the following projection is true?

- a) Frontview-line, topview-hexagon
- b) Frontview-hexagon, topview-line
- c) Frontview–line, topview-line
- d) Top view- hexagon, side view- line

4. A line AB is on the vertical plane of projection planes, which view from the following gives the actual length of the line AB?

- a) Front view
- b) Top view
- c) Side view
- d) Isometric view



Signature of HOD

Date:

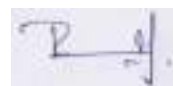

Signature of faculty

Date:

Department of Mechanical Engineering

:

TUTORIAL SHEET – 3

This tutorial corresponds to Unit No. 3 (Objective Nos.: 3, Outcome Nos.: 3)

1. When a solid is placed such that axis is inclined with both the H.P and V.P. Its projections are drawn in _____ stages.

- a) 1
- b) 4
- c) 2
- d) 3

2. When the axis of a solid is parallel to a plane, the projection of the solid shows the true shape and size of its base.

- a) False
- b) True

3. When the axis of a solid perpendicular to H.P _____ should be drawn first.

- a) Top view
- b) Front view
- c) Side view
- d) Rare view

4. When the axis of a solid perpendicular to V.P, _____ should be drawn first.

- a) Top view
- b) Front view
- c) Side view
- d) Rare view



Signature of HOD

Date:

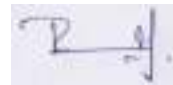

Signature of faculty

Date:

Department of Mechanical Engineering

TUTORIAL – 4

This tutorial corresponds to Unit No. 4 (Objective Nos.: 3, Outcome Nos.: 3)

1. What is the method of development of a cube?

- a) Parallel line method
- b) Radial line method
- c) Triangulation method
- d) Approximate method

2. When the development of the curved surface of a cone is a _____

- a) Sector of a circle
- b) Segment of a circle
- c) Segment of an ellipse
- d) None of the above

3. Approximate development is the method of developing of non-developable surfaces, by divided the surface of the object into _____

- a) Parallel parts
- b) Triangular parts
- c) Circular parts
- d) Zone and lune

4. In _____ development method, the surface is divided into parts of parallel lines to determine the surface.

- a) Approximate development
- b) Parallel line development
- c) Triangulation method
- d) Radial line development



Signature of HOD

Date:

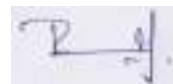

Signature of faculty

Date:

Department of Mechanical Engineering**TUTORIAL SHEET – 5**

This tutorial corresponds to Unit No. 5 (Objective Nos.: 5, Outcome Nos.: 5)

1.If isometric projection of an object is drawn with true lengths the shape would be same and size is how much larger than actual isometric projection?

- a) 25%
- b) 29.5%
- c) 22.5%
- d) 33.3%

2. If an isometric projection is drawn with true measurements but not with isometric scale then the drawings are called _____

- a) Isometric projection
- b) Isometric view
- c) Isometric perception
- d) Orthographic view

3.If an isometric drawing is made use of isometric scale then the drawings are called _____

- a) Isometric projection
- b) Isometric view
- c) Isometric perception
- d) Orthographic view

4. Isometric projection comes under which category of projections-----

- a) Axonometric projection
- b) Perspective projection
- c) Oblique projection
- d)None of the above



Signature of HOD

Date:

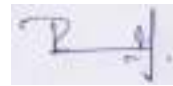

Signature of faculty

Date:

Department of Mechanical Engineering

EVALUATION STRATEGY

Target (s)

- a. Percentage of Pass : 95%

Assessment Method (s) (Maximum Marks for evaluation are defined in the Academic Regulations)

- a. Daily Attendance
- b. Assignments
- c. Online Quiz (or) Seminars
- d. Continuous Internal Assessment
- e. Semester / End Examination

List out any new topic(s) or any innovation you would like to introduce in teaching the subjects in this semester

Case Study of any one existing application



Signature of HOD

Date:

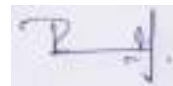

Signature of faculty

Date:

Department of Mechanical Engineering
COURSE COMPLETION STATUS

Actual Date of Completion & Remarks if any

Units	Remarks	Objective No. Achieved	Outcome No. Achieved
Unit 1	completed on 24.02.2024	1	1
Unit 2	completed on 16.03.2024	2	2
Unit 3	completed on 24.04.2024	3	3
Unit 4	completed on 04.05.2024	4	4
Unit 5	completed on 07.06.24	5	5



Signature of HOD

Date:

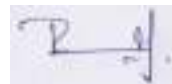

Signature of faculty

Date:

Department of Mechanical Engineering

Mappings

1. Course Objectives-Course Outcomes Relationship Matrix

(Indicate the relationships by mark "X")

Course-Objectives \ Course-Outcomes	1	2	3	4	5
1	H			M	
2		L			
3			H		
4		M			
5					M

2. Course Outcomes-Program Outcomes (POs) & PSOs Relationship Matrix

(Indicate the relationships by mark "X")

P-Outcomes \ C-Outcomes	a	b	c	d	e	f	g	h	i	j	k	l	PSO 1	PSO 2
1	L		M		M									
2	L		M		H						H	M	M	
3	M		M		H						H	M		L
4	H		M		H								M	
5	H						M				H	L		

Department of Mechanical Engineering

Rubric for Evaluation

Performance Criteria	Unsatisfactory	Developing	Satisfactory	Exemplary
	1	2	3	4
<i>Research & Gather Information</i>	Does not collect any information that relates to the topic	Collects very little information some relates to the topic	Collects some basic Information most relates to the topic	Collects a great deal of Information all relates to the topic
<i>Fulfill team role's duty</i>	Does not perform any duties of assigned team role.	Performs very little duties.	Performs nearly all duties.	Performs all duties of assigned team role.
<i>Share Equally</i>	Always relies on others to do the work.	Rarely does the assigned work - often needs reminding.	Usually does the assigned work - rarely needs reminding.	Always does the assigned work without having to be reminded
<i>Listen to other team mates</i>	Is always talking— never allows anyone else to speak.	Usually doing most of the talking-- rarely allows others to speak	Listens, but sometimes talks too much.	Listens and speaks a fair amount.

Department of Mechanical Engineering



I B.TECH II SEMESTER I MID EXAMINATIONS - APRIL 2024

Branch : B.Tech. (ECE & IT)

Max. Marks: 30

Date : 03 - Apr - 2024 FN

Time: 120 Minutes

Subject : Computer Aided Engineering Graphics, EG203ES

PART - A

ANSWER ALL QUESTIONS

10 X 1 M = 10 M

Q.No	Question	CO	BTL
1.	The angle between the asymptotes of a rectangular hyperbola is () (A). 30 0 (B). 45 0 (C). 60 0 (D). 90 0	CO1	1
2.	Eccentricity for an Ellipse? () (A). Less than 1 (B). Equal to 1 (C). Greater than 1 (D). None of the above	CO1	1
3.	If the plane cuts at an angle to the axis but does not cut all the generators then what is the name of the conics formed? (A). Ellipse (B). Hyperbola (C). Circle (D). Parabola	CO1	1
4.	In general method of drawing an ellipse, a vertical line called as _____ is drawn first. (A). Tangent (B). Normal (C). Major axis (D). Directrix	CO1	2
5.	The line joining the front and top views of a point is called? (A). reference line (B). projector (C). connector (D). locus	CO2	1
6.	If a line is parallel to both H.P and V.P., its true length will be seen in () (A). front view (B). top view (C). Side view (D). Both front and top views	CO2	1
7.	If a line is in profile plane making an angle of 30 degrees with vertical plane. In which angle the line makes with the horizontal plane? (A). 30 0 (B). 90 0 (C). 0 0 (D). 60 0	CO2	1
8.	A square of side is resting on the H.P. What is the top view of object? (A). Circle (B). Ellipse (C). square (D). Line	CO2	2
9.	A solid is an object having _____ () (A). one dimension (B). two dimension (C). three dimension (D). four dimension	CO3	1
10.	When a solid is placed such that axis is inclined with both the H.P and V.P. Its projections are drawn in _____ stages. (A). 1 (B). 2 (C). 3 (D). 4	CO3	2

Department of Mechanical Engineering

PART - B

ANSWER ANY FOUR

4 X 5 M = 20 M

Q.No	Question	CO	BTL
11.	Construct a parabola, with the distance between the focus and the directrix as 60 mm. Also, draw normal and tangent to the curve at a point 30 mm from the directrix.	CO1	3
12.	Construct a hyperbola, with the distance between the focus and the directrix as 50 mm and eccentricity as 3/2. Also, draw normal and tangent to the curve at a point 30 mm from the directrix.	CO1	2
<hr/>			
13.	A line AB measures 100mm is inclined at an angle of 30° to HP and 40° to VP. The point A is 20mm above HP and 30mm in front of VP. Draw the projections of the line.	CO2	3
14.	A line CD measures 80mm is inclined at an angle of 30° to HP and 45° to VP. The point C is 20mm above HP and 30mm in front of VP. Draw the projections of the line.	CO2	3
15.	A Pentagonal pyramid, side of base 25 mm and axis 60 mm long, rests with one of the edge of its base on HP and its axis is inclined at 45° to HP and parallel to VP. Draw its projections.	CO3	4
16.	A cone of base diameter 50 mm and axis 60 mm long, rests with its base on HP and its axis is inclined at 45° to HP and parallel to VP. Draw its projections.	CO3	3

Department of Mechanical Engineering



I B.TECH II SEMESTER II MID EXAMINATIONS - JUNE 2024

Branch : B.Tech. ECE & IT

Max. Marks : 30M

Date : 20-Jun-2024 Session : Morning

Time : 120 Min

Subject : Computer Aided Engineering Graphics,EG203ES

PART - A

ANSWER ALL THE QUESTIONS

10 X 1M= 10M

Q.No	Question	CO	BTL
1.	When the axis of a solid perpendicular to H.P _____ should be drawn first. (A). Top view (B). Front view (C). Side view (D). Rare view	CO3	1
2.	When a solid is placed such that axis is inclined with both the H.P and V.P. Its projections are drawn in _____ stages. (A). 1 (B). 4 (C). 2 (D). 3	CO3	1
3.	The development of the lateral surface of a cylinder is a rectangle having one side equal to the _____ of its base-circle and the other equal to its length. (A). circumference (B). area (C). diameter (D). radius	CO4	2
4.	What will be the value of the radius of the arc in the development of the pyramids? (A). Height of the pyramid (B). The slant height of the pyramid (C). 4*Side of the pyramid (D). 0.5*Height of the pyramid	CO4	1
5.	Approximate development is the method of developing of non-developable surfaces, by divided the surface of the object into _____ (A). Parallel parts (B). Triangular parts (C). Circular parts (D). Zone and lune	CO4	2
6.	In _____ development method, the surface is divided into parts of parallel lines to determine the surface. (A). Approximate development (B). Parallel line development (C). Triangulation method (D). Radial line development	CO4	1
7.	Which of the projection is mainly used in engineering practice _____ (A). Perspective projection (B). Isometric projection (C). Orthographic projection (D). Oblique projection	CO5	1
8.	The isometric projection of a sphere is _____ (A). Ellipse (B). circle (C). Sphere (D). None of the above	CO5	1
9.	If an isometric projection is drawn with true measurements but not with isometric scale then the drawings are called _____ (A). Isometric projection (B). Isometric view (C). Isometric perception (D). Orthographic view	CO5	1
10.	Isometric projection comes under which category of projections----- (A). Axonometric projection (B). Perspective projection (C). Oblique projection (D). None of the above	CO5	1

Department of Mechanical Engineering

PART - B

ANSWER ANY FOUR

4 X 5M = 20M

Q.No Question

CO BTL

Page : 1

- | | | | |
|-----|---|-----|---|
| 11. | A square pyramid, side of base 40 mm and axis height 60 mm is resting on its base edge on the HP. With a side of base parallel to VP. Draw its sectional view and true shape of the section, if it cut by a section plane perpendicular to the VP, bisecting the axis and inclined at angle 45° to the H.P. | CO3 | 3 |
| 12. | A pentagonal pyramid, side of base 30 mm and axis height 60 mm is resting on its base edge on the HP. With a side of base parallel to VP. Draw its sectional view and true shape of the section, if it cut by a section plane perpendicular to the VP, bisecting the axis and inclined at angle 45° to the H.P. | CO3 | 3 |
| 13. | A cone of base diameter is 50mm and axis 60mm long is resting with its base on HP. It is cut by a section plane perpendicular to the VP and inclined at 45° to the HP and bisecting axis. Draw the development. | CO4 | 3 |
| 14. | A Pentagonal prism edge of base 20mm and axis 50mm long, rest with its corner on the HP such that one of its rectangular face is parallel to VP. It is cut by a plane perpendicular to the VP, inclined at 45° HP and passing through the right corner of top face of the prism. Draw the development of lateral surface of the truncated prism. | CO4 | 4 |
| 15. | Draw front view, top view and side view of given figure. | CO5 | 4 |

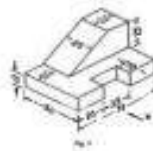

Department of Mechanical Engineering

Continuous Internal Assessment (R-22)

Programme: **B.Tech**Year: **I**Course: **Theory**A.Y: **2023-24**Course: **CAEG**Section: **IT**Faculty Name: **L.RAMESH**

S. No	Roll No	MID-I (35M)	MID-II (35M)	Avg. of MID I & II	Viva- Voce/Poster Presentation (5M)	Total Marks (40)
1	23C11A1201	16	23	20	5	25
2	23C11A1202	15	0	8	5	13
3	23C11A1203	32	35	34	5	39
4	23C11A1204	6	31	19	5	24
5	23C11A1205	29	31	30	5	36
6	23C11A1206	33	33	33	5	38
7	23C11A1207	27	33	30	5	35
8	23C11A1208	13	0	7	5	12
9	23C11A1209	30	33	32	5	37
10	23C11A1210	33	34	34	5	39
11	23C11A1211	30	34	32	5	37
12	23C11A1212	26	30	28	5	33
13	23C11A1213	34	34	34	5	39
14	23C11A1214	22	20	21	5	27
15	23C11A1215	30	31	31	5	36
16	23C11A1216	8	21	15	5	20

Department of Mechanical Engineering

17	23C11A1217	7	0	4	5	9
18	23C11A1218	7	15	11	5	16
19	23C11A1219	14	16	15	5	21
20	23C11A1220	29	24	27	5	32
21	23C11A1221	30	31	31	5	36
22	23C11A1222	22	33	28	5	33
23	23C11A1223	28	27	28	5	33
24	23C11A1224	0	0	0	AB	0
25	23C11A1225	30	33	32	5	37
26	23C11A1226	22	11	17	5	22
27	23C11A1227	34	32	33	5	38
28	23C11A1228	22	21	22	5	27
29	23C11A1229	9	14	12	5	17
30	23C11A1230	21	20	21	5	26
31	23C11A1231	25	30	28	5	33
32	23C11A1232	26	25	26	5	31
33	23C11A1233	13	20	17	5	22
34	23C11A1234	15	20	18	5	23
35	23C11A1235	9	0	5	5	10
36	23C11A1236	19	17	18	5	24
37	23C11A1237	28	29	29	5	34
38	23C11A1239	33	32	33	5	38
39	23C11A1242	25	23	24	5	29
40	23C11A1243	11	15	13	5	19

Department of Mechanical Engineering

41	23C11A1244	23	32	28	5	33
42	23C11A1245	30	24	27	5	32
43	23C11A1246	21	30	26	5	31
44	23C11A1247	24	29	27	5	32
45	23C11A1248	19	11	15	5	21
46	23C11A1249	13	7	10	5	15
47	23C11A1250	22	20	21	5	26
48	23C11A1251	26	28	27	5	32
49	23C11A1252	20	18	19	5	24
50	23C11A1253	31	33	32	5	37
51	23C11A1254	34	32	33	5	38
52	23C11A1255	35	34	35	5	40
53	23C11A1256	20	24	22	5	28
54	23C11A1257	7	22	15	5	20
55	23C11A1259	19	22	21	5	26

No. of Absentees: 01

Total Strength: 55

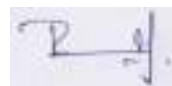

Signature of Faculty



Signature of HoD

Department of Mechanical Engineering

COURSE MATERIAL

I Year B. Tech II- Semester

MECHANICAL

ENGINEERING

**COMPUTR AIDED ENGINEERING
GRAPHICS**

Department of Mechanical Engineering

Engineering Graphics is the principal method of communication in the field of engineering and science. The graphics of engineering design and construction is one among the most important courses of all studies for engineering. It is the language used by the designer, technician and engineer to communicate, design and construct details to others.

The Graphic Language

Engineering drawing is the graphic language used by engineers and technologists globally. The graphic language may be defined as the graphic representation of physical objects and their relationships. This language is written in the form of drawings using straight and curved lines which represent the shape, size and specifications of physical objects. The language is read by interpreting the drawings so that the physical objects can be constructed exactly as conceived by the designer. An engineer, should have proper understanding of the theory of projection, dimensioning and conventions related to working drawings, in order to become professionally efficient.

Traditional Drafting

Engineering drawings are made up of straight and curved lines to represent the surfaces, edges and centres of objects. Symbols, dimensional values and word-notes are added to these lines so that they collectively make the complete description. The traditional drafting is the presentation of these drawings manually, by freehand sketching or with the help of drawing instruments.

Computer Aided Drafting

Computer Aided Drafting is a process of preparing a drawing of an object on the screen of a computer. There are various types of drawings in different fields of engineering and sciences. In the fields of mechanical or aeronautical engineering, the drawings of machine components and the layouts of them are prepared. In the field of civil engineering, plans and layouts of the buildings are prepared. In the field of electrical engineering, the layouts of power distribution system are prepared. In all fields of engineering use of computer is made for drawing and drafting.

The use of CAD process provides enhanced graphics capabilities which allows any designer to

- Conceptualize his ideas
- Modify the design very easily
- Perform animation
- Make design calculations
- Use colors, fonts and other aesthetic features

Benefits of CAD

The implementation of the CAD system provides variety of benefits to the industries in design and production as given below:

1. Improved productivity in drafting
2. Shorter preparation time for drawing
3. Reduced man power requirement
4. Customer modifications in drawing are easier
5. More efficient operation in drafting
6. Low wastage in drafting

Department of Mechanical Engineering

7. Minimized transcription errors in drawing
8. Improved accuracy of drawing
9. Assistance in preparation of documentation
10. Better designs can be evolved
11. Revisions are possible
12. Colours can be used to customize the product
13. Production of orthographic projections with dimensions and tolerances
14. Hatching of all sections with different filling patterns
15. Preparation of assembly or sub assembly drawings
16. Preparation of part list
17. Machining and tolerance symbols at the required surfaces
18. Hydraulic and pneumatic circuit diagrams with symbols
19. Printing can be done to any scale

CAD SOFTWARES

The software is an interpreter or translator which allows the user to perform specific type of application or job related to CAD. The following software's are available for drafting

1. AUTOCAD
2. CREO
3. CATIA
4. SOLID WORKS
5. NX Unigraphics
6. FUSION 360
7. INVENTOR
8. SOLID EDGE

Drawing Instruments and aids:

Drawing Instruments are used to prepare drawings easily and accurately. A neat and clean drawing is prepared by the help of good quality drawing instruments and other aids. The following are the drawing aids commonly used in industries:

- Drawing board
- Setsquares
- French curves
- Templates
- Mini drafter
- Instrument box
- Protractor
- Set of scales
- Drawing sheets
- Pencils

Department of Mechanical Engineering

UNIT 1

INTRODUCTION TO COMPUTER AIDED ENGINEERING GRAPHICS

Department of Mechanical Engineering

Engineering Graphics

Engineering Graphics is the principal method of communication in the field of engineering and science. The graphics of engineering design and construction is one among the most important courses of all studies for engineering. It is the language used by the designer, technician and engineer to communicate, design and construct details to others.

The Graphic Language

Engineering drawing is the graphic language used by engineers and technologists globally. The graphic language may be defined as the graphic representation of physical objects and their relationships. This language is written in the form of drawings using straight and curved lines which represent the shape, size and specifications of physical objects. The language is read by interpreting the drawings so that the physical objects can be constructed exactly as conceived by the designer. An engineer, should have proper understanding of the theory of projection, dimensioning and conventions related to working drawings, in order to become professionally efficient.

Traditional Drafting

Engineering drawings are made up of straight and curved lines to represent the surfaces, edges and centres of objects. Symbols, dimensional values and word-notes are added to these lines so that they collectively make the complete description. The traditional drafting is the presentation of these drawings manually, by freehand sketching or with the help of drawing instruments.

Computer Aided Drafting

Computer Aided Drafting is a process of preparing a drawing of an object on the screen of a computer. There are various types of drawings in different fields of engineering and sciences. In the fields of mechanical or aeronautical engineering, the drawings of machine components and the layouts of them are prepared. In the field of civil engineering, plans and layouts of the buildings are prepared. In the field of electrical engineering, the layouts of power distribution system are prepared. In all fields of engineering use of computer is made for drawing and drafting.

The use of CAD process provides enhanced graphics capabilities which allows any designer to

- Conceptualize his ideas
- Modify the design very easily
- Perform animation
- Make design calculations
- Use colors, fonts and other aesthetic features.

Department of Mechanical Engineering

Benefits of CAD

The implementation of the CAD system provides variety of benefits to the industries in design and production as given below:

1. Improved productivity in drafting
2. Shorter preparation time for drawing
3. Reduced man power requirement
4. Customer modifications in drawing are easier
5. More efficient operation in drafting
6. Low wastage in drafting
7. Minimized transcription errors in drawing
8. Improved accuracy of drawing
9. Assistance in preparation of documentation
10. Better designs can be evolved
11. Revisions are possible
12. Colours can be used to customize the product
13. Production of orthographic projections with dimensions and tolerances
14. Hatching of all sections with different filling patterns
15. Preparation of assembly or sub assembly drawings
16. Preparation of part list
17. Machining and tolerance symbols at the required surfaces
18. Hydraulic and pneumatic circuit diagrams with symbols
19. Printing can be done to any scale

CAD SOFTWARES

The software is an interpreter or translator which allows the user to perform specific type of application or job related to CAD. The following softwares are available for drafting

1. AUTOCAD
2. CREO
3. CATIA
4. SOLID WORKS
5. NX Unigraphics
6. FUSION 360
7. INVENTOR
8. SOLID EDGE

The above software's are used depending upon their application

Department of Mechanical Engineering

Drawing Instruments and aids:

Drawing Instruments are used to prepare drawings easily and accurately. A neat and clean drawing is prepared by the help of good quality drawing instruments and other aids. The following are the drawing aids commonly used in industries:

- Drawing board
- Setsquares
- French curves
- Templates
- Mini drafter
- Instrument box
- Protractor
- Set of scales
- Drawing sheets
- Pencils

Drawing Sheet:

Engineering drawings are prepared on standard size drawing sheet. The correct shape and size of the object can be visualized from the understanding of not only its views but also from the various types of lines used, dimensions, notes, scales etc., The standard drawing sheet sizes are arrived at on the basic Principal of $X:Y = 1: \sqrt{2}$ and $XY=1$ where x and y are the sides of the sheet. For example, A0, having a surface area of 1Sq.m; $X=841\text{mm}$ and $Y=1189\text{mm}$. The successive sizes are obtained by either by halving along the length or doubling the width, the area being in the ratio 1:2. Designation of sizes is given in the fig. For class work use of A2 size drawing sheet is preferred.

Designation	Trimmed Sizes in mm (width x length)
A0	841 x 1189
A1	594 x 841
A2	420 x 594
A3	297 x 420
A4	210 x 297

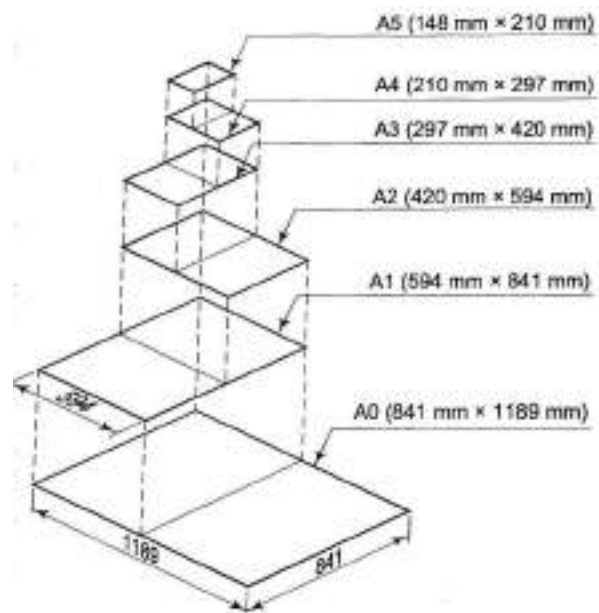

Department of Mechanical Engineering

Drawing Sheet Layout

It is an important function of engineering drawing. Also, it is very important to understand the standard for the selection of suitable scale, margin space, title block and part list etc., on the sheet. The below mentioned details in the drawing sheet is according to IS 46:2003

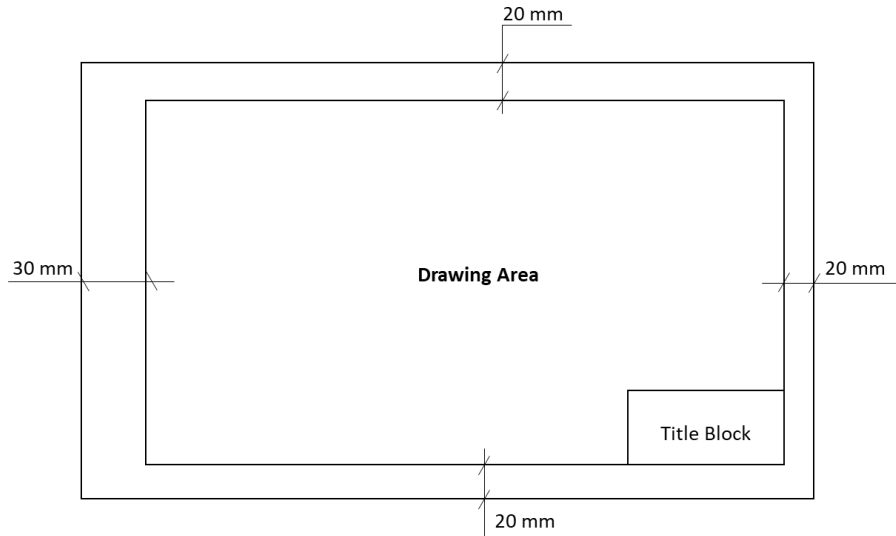

Title Block

Title block is to be placed within the drawing space at the bottom right hand corner of the drawing sheet and it should be visible when prints are folded. It should consist of one or more adjoining rectangles. These rectangles may be divided further into boxes for inserting specific information. The size of the title block as recommended by the B.I.S. is 185 mm x 65 mm for all designations of the drawing sheets. All the title blocks should contain at least the particulars mentioned below.

SN	Particulars
1	Name of the firm
2	Title of the Drawing
3	Scale
4	Symbol denoting the method of projection
5	Drawing number
6	Initials with dates of persons who have designed, drawn, checked, standards, and approved
7	No. of sheet and total number of sheets of the drawing of the object

The Title blocks used in industries and for class work purpose are shown below.

Department of Mechanical Engineering

	NAME	DATE	MATERIAL	TOLERANCE	FINISH
DRN					
CHD					
APPD					
PROJECTION	LEGAL OWNER	TITLE			
SCALE		IDENTIFICATION NUMBER			

Title Block for Industry

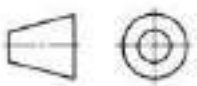
Name:	Title:	
Class	Sheet No.:	Date:
Roll No.	Projection:	
College:		

Title Block for Class Work

Types of Lines:







1. Outlines (A): Continuous thick or wide lines drawn to represent the visible edges and surface boundaries of the objects are called Outlines or Principal Lines.
2. Margin Lines (A): They are continuous thick or wide lines along which the prints are trimmed
3. Dimension lines (B): these lines are continuous thin lines that are terminated at the outer ends by pointed arrowheads touching the outlines, extension lines or centre lines.
4. Extension or Projection Lines (B): These are also continuous thin lines that extend by about 3mm beyond the dimension lines.
5. Construction Lines (B): These continuous thin light lines used for constructing figures.
6. Hatching or Section Lines (B): These are the continuous thin lines generally drawn at an angle of 45° to the main outline of the section and are uniformly spaced about 1mm to 2 mm apart. These are used to make the section evident.
7. Leader or pointer lines (B): It is a continuous thin line drawn to connect a note with the feature to which it applies.
8. Border Lines (B): Perfectly rectangular working space is determined by drawing the border lines.

Department of Mechanical Engineering

9. Short- break lines (C): These are continuous, thin and wavy lines drawn freehand and are used to show a short break or irregular boundaries.

Department of Mechanical Engineering

10. Long-break lines (D): These are thin ruled lines with short zigzags within them and are drawn to show the long breaks.
11. Hidden or dotted lines (E/F): Interior or hidden edges and surfaces are shown by hidden lines. They are also called as dotted lines.
12. Centre lines (G): These are thin, long, chain lines composed of alternately long and dot lines drawn to indicate the axes of cylindrical, conical or spherical objects or details and also to show the centres of circles and arcs.
13. Cutting-plane lines (H): The location of cutting plane is shown by this line. It is a long, thin, chain line, thick at ends only.

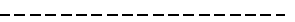
Line Type		Description	General Applications
A		Continuous thick or Continuous wide	Visible outlines, Visible edges, Main representations in diagrams, flow charts etc.,
B		Continuous thin (narrow)	Imaginary lines of intersection, Dimensions, Extension, Projection, Leader lines, Reference lines, Hatching, Construction lines, Outlines of revolved sections
C		Continuous thin (narrow) freehand	Limits of partial or interrupted views and sections, if the limit is not a chain thin line
D		Continuous thin (narrow) with zigzags	Long-break line
E		Dashed thick (wide)	Line showing permissible of surface treatment
F		Dashed thin (narrow)	Hidden outlines, hidden edges
G		Chain thin Long – dashed dotted	Centre lines, lines of symmetry, trajectories, Pitch circle of holes, Axes
H		Chain thin (narrow) with thick (wide) at the ends and at changing of the position	Cutting planes

Department of Mechanical Engineering

LETTERING

Lettering is defined as writing of titles, sub-titles, dimensions, and other important particulars on a drawing.

To undertake production work of an engineering component as per the drawing, the size and other details are indicated on the drawing. This is done in the form of notes and dimensions. Main features of lettering consume more time. Lettering should be done freehand with speed. Practice accompanied by continuous efforts would improve the lettering skill and style.

Size of Letters:

- Size of Letters is measured by the height h of the Capital Letters as well as numerals.
- Standard heights for Capital letters and numerals recommended by BIS are given below:
1.8, 2.5, 3.5, 5, 6, 10, 14, 20 mm

Note: Size of the letters may be selected based upon the size of the drawing.

Guide lines:

In order to obtain correct and uniform height of letters and numerals, guide lines are drawn using 2H pencil with light pressure. HB grade conical end pencil is used for lettering.

The following are some of the guidelines for lettering

- Drawing numbers, title block and letters denoting cutting planes, sections are written in 10mm size.
- Drawing title is written in 7 mm size.
- Hatching, subtitles, materials, dimensions, notes, etc., are written in 3.5mm size.
- Space between lines = $3/4h$
- Space between words may be

$$d = \frac{h}{10}$$

Characteristic	Ratio	Dimensions (mm)							
Lettering height Height of Capitals	h		2.5	3.5	5	7	10	14	20
Height of Lower-case letters	$\frac{5}{7}h$	-	2.5	3.5	5	7	10	14	
Spacing between characters	$\frac{2}{14}h$	0.35	0.5	0.7	1	1.4	2	2.8	
Minimum spacing of base lines	$\frac{10}{7}h$	3.5	5	7	10	14	20	2.8	
Minimum spacing between words	$\frac{3}{7}h$	1.05	1.5	2.1	3	4.2	6	8.4	
Thickness of lines	$\frac{1}{14}h$	0.18	0.25	0.35	0.5	0.7	1	1.4	

Characteristics of lettering as per BIS

Department of Mechanical Engineering

DIMENSIONING

A drawing describes the shape of an object. For complete details of an object, its size description is also required. The information like distance between surfaces and edges with tolerance, location of holes, machining symbols, surface finish, type of material, quantity, etc., is indicated on the drawing by means of lines symbols, and holes. The process of furnishing this information on a technical drawing as per a code of practice is called dimensioning.

Principles of dimensioning

1. Dimensioning should be done so completely that further calculation or assumption of anydimension or direct measurement from the drawing is not necessary
2. Every dimension must be given, but none should be given more than once.
3. A dimension should be placed on the view where its use is shown more clearly.
4. Dimensions should be placed outside the views, unless they are clearer and more easilyread inside.
5. Mutual crossing of dimension lines and dimensioning between hidden lines should beavoided. Dimension lines should not cross any other line of the drawing.
6. An outline or a centre line should never be used as a dimension line. A centre line mayextend to serve as an extension line
7. Aligned system of dimensioning is recommended.

Elements of dimensioning

1. Projection or extension Line

It is a thin continuous line drawn in extension of an outline. It extends by 3mm beyond the dimension line.

2. Dimension Line

It is a thin continuous line terminated by arrowheads touching the outlines, extension lines or centre lines.

3. Leader line

A leader line is a thin continuous line connecting a note or a dimension figure with the feature to which it applies. One end of the leader line terminated either in an arrowhead or a dot. The other end of the leader line is terminated in a horizontal line at a bottom level of the first or the last letter of the note. It is always drawn at a convenient angle of not less than 30° to the line which it touches.

4. Arrow head or Termination of dimension line

Department of Mechanical Engineering

An arrow head is placed at each end of a dimensional line. Its pointed end touches an outline, an extension line or a centre line. The size of an arrow head should be proportional to the

Department of Mechanical Engineering

thickness of the outlines. The length of the arrowhead should be three times its maximum width. Different types of arrowheads can be observed, but closed and filled type of arrowheads is widely used in engineering drawing.

Methods of indicating Dimensions

The two methods of indicating dimensions are:

1. Aligned
2. Unidirectional

1. Aligned method

In this method, the dimension is placed perpendicular to the dimension line such a way that it may be read from the bottom edge of the right-hand edge of the drawing sheet. The dimensions must be placed in the middle and above the dimension line.

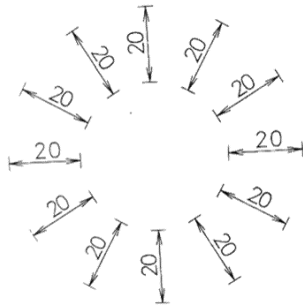

2. Unidirectional method

In unidirectional method, all the dimensions are placed in such a way that they can be read from the bottom edge of the drawing sheet. The dimension lines are broken near the middle for inserting the dimensions. This method is generally used on large drawings.

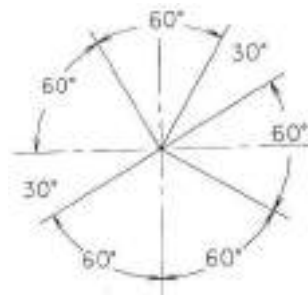
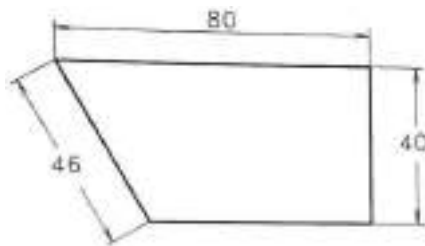

Arrangement of Dimension lines

The dimensions of an object can be placed according to either Aligned or Unidirectional methods, but they are arranged in the following ways and the selection depends on the design and the construction requirements.

1. Chain dimensioning

Department of Mechanical Engineering

This type of dimensioning is used only where the possible accumulation of tolerances does not endanger the functional requirements of the part.(fig.)

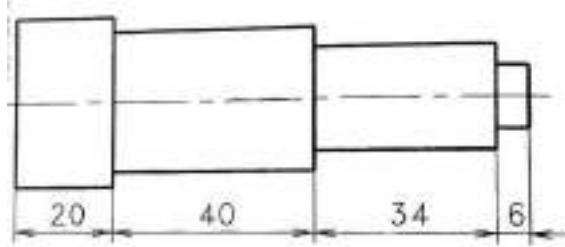

2. Parallel dimensioning

This type of dimensioning is used only where a number of dimensions of a part have common datum feature.

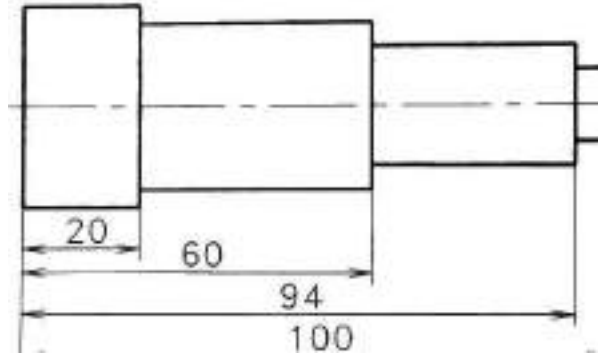

3. Combined dimensioning

In this a combination of both chain and parallel dimensioning are applied. But, the distance of dimension line from the object boundary or nearby dimensions line should be at least 5mm to 6mm.

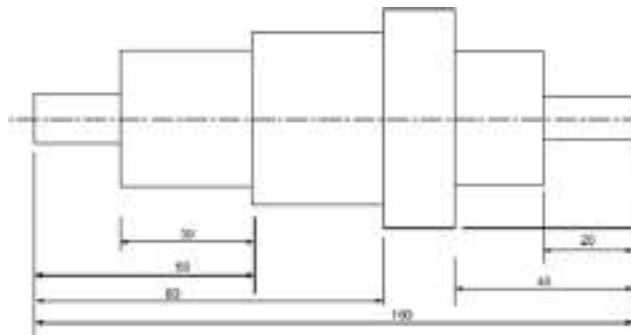

Department of Mechanical Engineering

4. Superimposed running dimensioning

This type of dimensioning is a simple parallel dimensioning and may be used where there are space limitations and where no legibility problems will arise. In this, origin is to be indicated appropriately and the opposite end of each dimension line should be terminated only with arrow head.

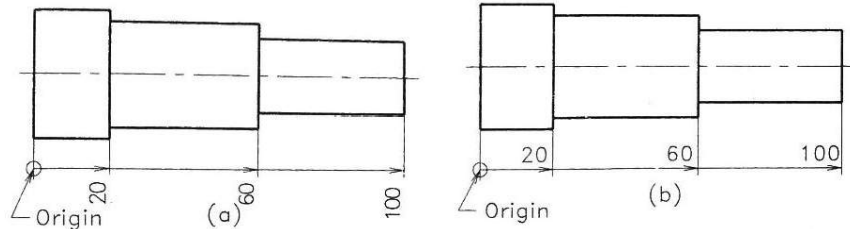

5. Dimensioning by coordinates

This type of dimensioning follows the principle of coordinate system of identifying the points.

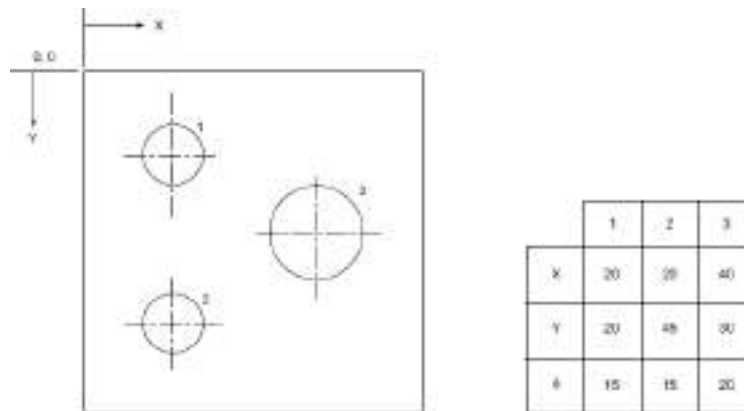

This type of dimensioning follows the principle of coordinate system of identifying the points. There are three ways of indicating this type of dimensioning.

Department of Mechanical Engineering

AutoCAD Installation Process

1. Go to the following website: <https://www.autodesk.com/education/free-software/all>
2. Click **AutoCAD**
3. Create your login account using the MRCET mail id. xyz@mrcet.ac.in (you can access the software for 3 Years).
4. After you create your account, sign in and choose
 - a. Version: AutoCAD 2020
 - b. Operating System: 32 or 64 bit
(To find the information, Right click on **My Computer or My PC** and select properties.)
 - c. Language: English (so you can have more effective technical support)
5. Serial number and Product key will be displayed. This information is required at the time of activation after installing the software.
6. Download can be carried in two ways:
 - a. Download Now (Recommended)
 - b. Browser Download
7. After downloading the file, double click on the installation file, and then click **Yes** to complete the installation.
8. Now click on **Install**
9. Check the box **I accept** the click **next**
10. For the standalone License type default option, enter the serial key & product key details found on the software database for this software version.
11. Click **Install** and the Click **Finish** to complete the installation.

System Requirements

- Operating System : 32 or 64-bit Microsoft Windows/ XP-professional/vista or more
- Processor : Pentium 4 or later
- RAM : 4GB or more
- Graphics Card : 1GB or more/ integrated graphics
- Hard Disk : 20GB free hard disk space available including installation
- Pointing devices : Mouse, digitizer with win tab drive, Keyboard
- DVD ROM : Any Speed (not mandatory)

Department of Mechanical Engineering

Function Keys

The keyboard function keys F1-F12 control settings that are commonly turned on and off as we work in the product.

Key	Feature	Description
F1	Help	Displays Help for the active tooltip, command, Palette or dialog box.
F2	Expanded History	Displays an expanded command history in the Command window
F3	Object Snap	Turns object snap ON and OFF
F4	3D Object Snap	Turns additional object snaps for 3D ON and OFF
F5	Isoplane	Cycles through 2D isoplane settings (Top, Right and Left)
F6	Dynamic UCS	Turns automatic UCS alignment with planar surfaces ON and OFF
F7	Grid display	Turns the grid display ON and OFF
F8	Ortho	Locks cursor movement to horizontal or vertical
F9	Grid Snap	Restricts cursor movement to specified grid intervals
F10	Polar Tracking	Guides cursor movement to specified angles
F11	Object Snap Tracking	Tracks the cursor horizontally and vertically from object snap locations
F12	Dynamic input	Displays distances and angles near the cursor and accepts input as we use Tab between fields

Note: F8 and F10 are mutually exclusive -turning one On will turn the other OFF.

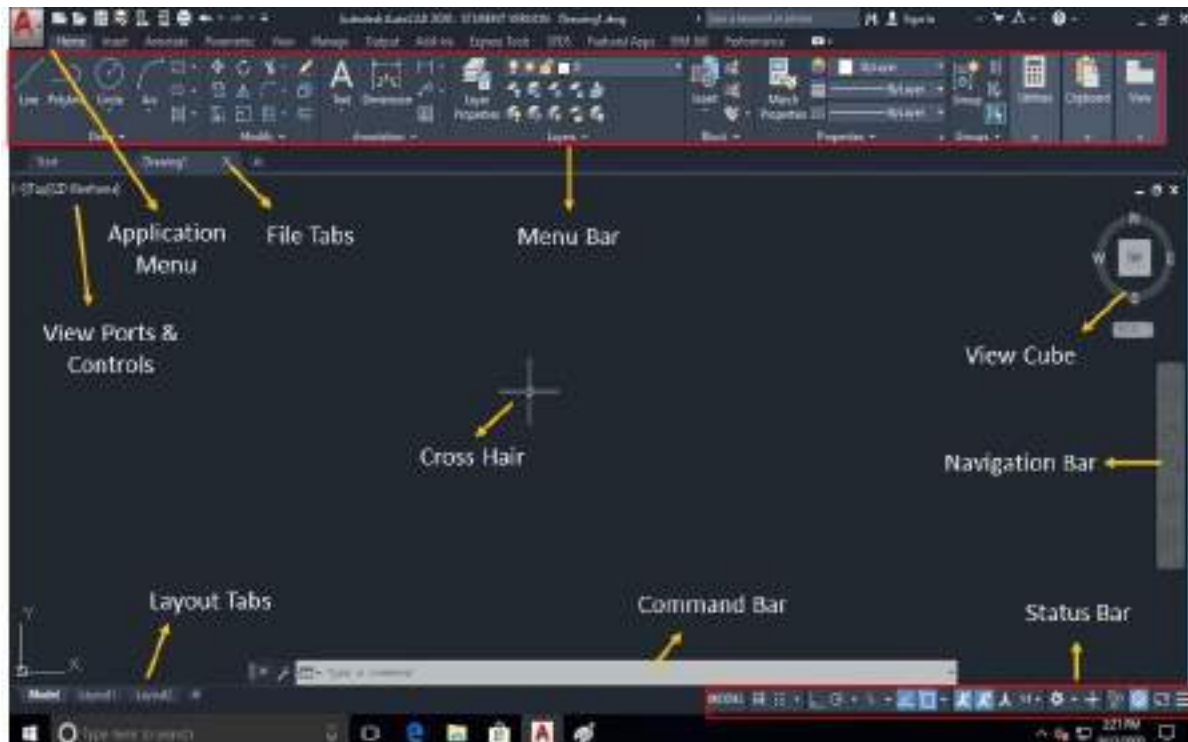
Department of Mechanical Engineering**User Interface****Application Menu**

Menus are available through the application button in the upper left corner of the drawing window. This menu contains the commands used to create, save, print, and manage your drawing.

Department of Mechanical Engineering

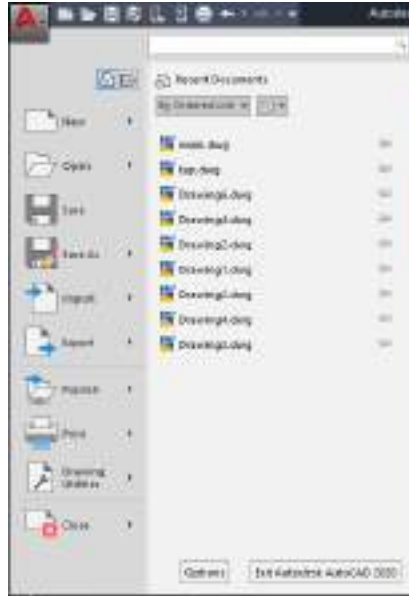

Department of Mechanical Engineering

Command prompt

The rectangular horizontal window at lower side of the screen is called the command area. The instructions given to the computer through keyboard is shown in this area. It important to read the command prompt when working with an unfamiliar command.

To enter a command using the keyboard, type the command name on the command line and press Enter or the Spacebar.

Navigation Bar

The navigation bar is a user interface element where you can access both unified and product-specific navigation tools. Unified navigation tools are those that can be found across many Autodesk products. Product-specific navigation tools are unique to a product.



Quick access toolbar

The Quick Access toolbar, displayed in the Drafting & Annotation workspace, is located at the very top of the drawing window next to the Application button. The Quick Access toolbar may be customized by adding or removing commands. This is done by right clicking on the toolbar and selecting Customize Quick Access toolbar or selecting the arrow at the end of the toolbar.



The Quick Access toolbar contains the following commands:

- QNew: Opens a new drawing.
- Open: Opens an existing drawing. (Ctrl+O)
- Save: Saves the current drawing. (Ctrl+S)
- Save as: Allows you to save the current drawing under a different name. (Ctrl+Shift+S)
- Plot: Plots or prints the current drawing. (Ctrl+P)
- Undo: Used to undo previous command or actions.
- Redo: Used to redo commands that have been undone.

Drawing area & Cross Hair

The rectangular large space between the pull-down menu bar and the command window is the drawing area. The cursor moves moves in this area in the form of a cross hair as mouse is moved by the user. The cross hair position is indicated by coordinate values shown at the left end of the status bar.

View Cube

The View Cube is a navigation tool that allows you to switch between viewing directions. While this is very useful in 3D space, it is not very useful in 2D space. It is located in the upper right corner of the drawing area.

Department of Mechanical Engineering

Status bar

The status bar displays the cursor location, drawing tools, and the tools that affect the drawing environment. It also provides quick access to some of the most commonly used drawing tools, Coordinates of the cross hair (Cursor) and we can toggle the settings such as grid, snap, polar tracking and object snap.



Draw Commands

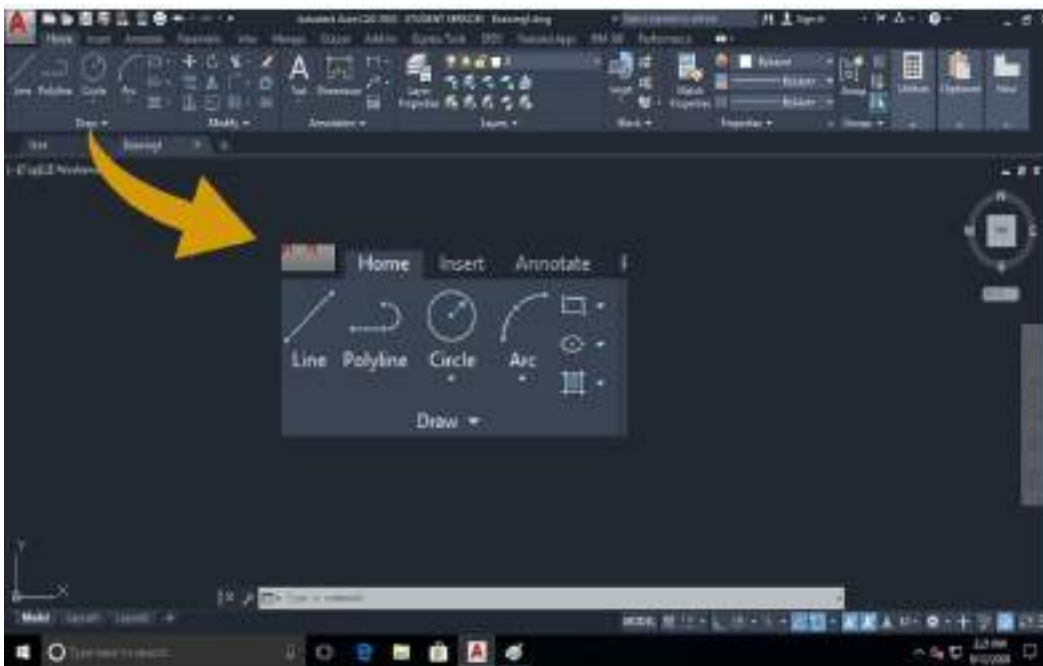

1. Point:

The Point command will insert a point marker in your drawing at a position which you pick or at any coordinate location which you enter in the Command window. Other ways of defining a point can be accessed through the fly-out menu. The default point style is a simple dot, which

Department of Mechanical Engineering

is often difficult to see but you can change the point style to something more easily visible or elaborate using the point style dialogue box.

Tool Bar: Menu → Draw → Point

Command: Point (PO)

2. Line:

Creates a straight line segment. It is used to draw lines continuously. Each segment is a line object that can be edited separately.

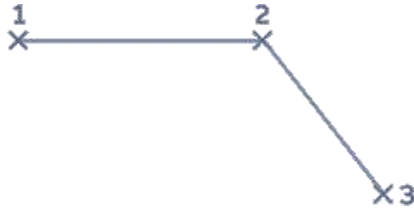

Continue: Continues a line from the endpoint of the most recently drawn line.

Close: End the line segment at the beginning of the first line segment, which forms a closed loop of line segment.

Undo: Erases the most recent segment of a line sequence.

Tool Bar: Menu → Draw → Line

Command: Line (L)

3. Construction Line (XL):

The construction line (XLINE) command creates a line of infinite length which passes through two picked points. Construction lines are very useful for creating construction frameworks or grids. Construction lines are not normally used as objects in finished drawings. Therefore, it is usual to draw all your construction lines on a separate layer which will be turned off or frozen prior to printing.

Construction line options

- **Hor:** Creates a horizontal construction line.
- **Ver:** Creates a vertical construction line.
- **Ang:** Creates a construction line at a specified angle.
- **Bisect:** Create a construction line that bisects an angle defined by 3 points.
- **Offset:** Creates a construction line that is offset from an existing line by a specified distance.

Tool Bar: Menu → Draw → Xline

Command: Xline (xl)

Department of Mechanical Engineering

4. Polyline (Pline):

The PLINE command differs from the LINE command in that the segments of the PLINE are connected. When using the LINE command, each segment is its own object. When using PLINE, all line segments are one object.

Tool Bar: **Menu** → **Draw** → **Polyline**

Command: **Pline (PL)**

5. Polygon

A polygon of sides ranging from 3 to any number can be drawn using Polygon command. It creates an equilateral closed polyline.

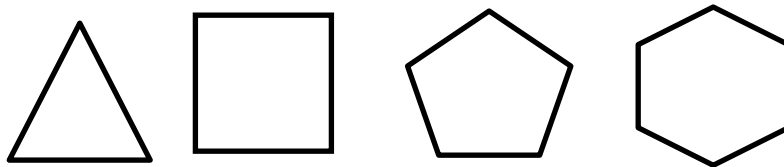

Centre of Polygon: Defines the center of the polygon.

Inscribed in Circle: Specifies the radius of a circle on which all vertices of the polygon line.

Circumscribe about circle: Specifies the distance from the centre of the polygon to the midpoints of the edges of the polygons.

Edge: Defines a polygon by specifying the endpoints of the first edge.

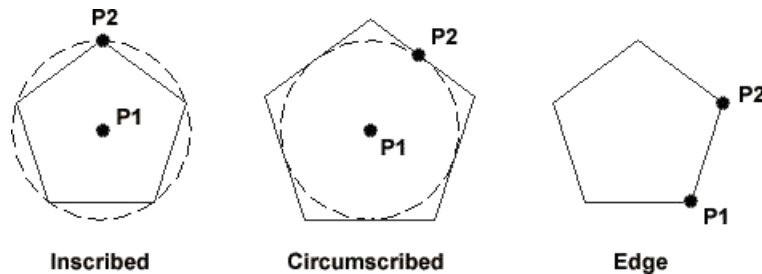

Specifying the radius with your pointing device determines the rotation and size of the polygon. Specifying the radius with a value draws the bottom edge of the polygon at the current snap rotation angle.

Tool Bar: **Menu** → **Draw** → **Polygon**

Command: **Polygon**

6. Arc

This command is used to draw an arc accurately. To create an arc, a combination of centre,

Department of Mechanical Engineering

endpoint, start point, radius, angle, chord length, and direction values can be specified. Arcs are drawn in a counter clockwise direction by default.

Start Point: Draws an arc

Department of Mechanical Engineering

Tool Bar: **Menu** → **Draw** → **Arc**

Command: **Arc**

7. Circle

There are many ways to draw a circle, the default being the centre point of circle and radius. Below are the possible ways of drawing the circle.

- i. **Centre point and Radius:** Defines the radius of the circle.

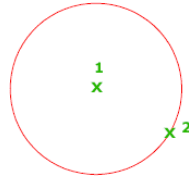

- ii. **Centre point and Diameter:** Defines the diameter of the circle.

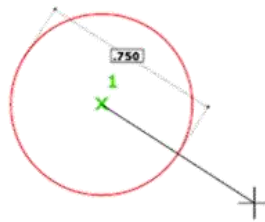

- iii. **3P (Three Points):** Draws a circle based on three points on circumference.

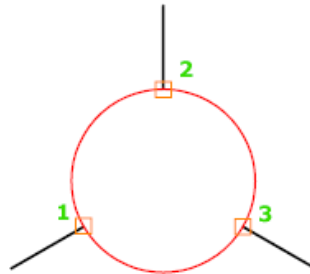

- iv. **2P (Two Points):** Draws a circle based on two endpoints of the diameter.

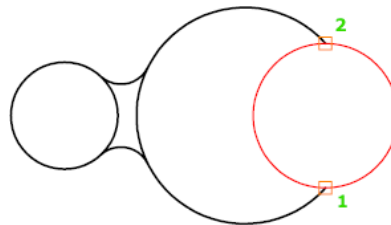

- v. **Tan, Tan, Tan:** Creates a circle tangent to three objects.

Department of Mechanical Engineering

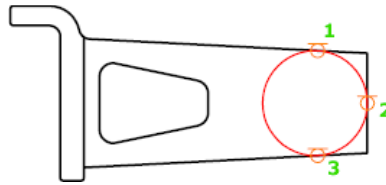

- vi. **Tan, Tan, Radius:** Creates a circle with a specified radius and tangent to two objects. Sometimes more than one circle matches the specified criteria. The program draws the circle of the specified radius whose tangent points are closest to the selected

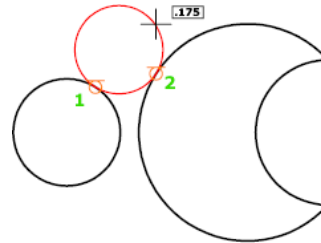

points.

Tool Bar: **Menu** → **Draw** → **Circle**

Command: **Circle (C)**

Ellipse

The Ellipse command gives you a number of different creation options. The default option is to pick the two end points of an axis and then a third point to define the eccentricity of the ellipse.

Tool Bar: **Menu** → **Draw** → **Ellipse**

Command: **Ellipse (E)**

8. Donut

The DONUT is a special type of polyline which is made up of arc segments. A DONUT has two properties: it has width, and it is closed. The width of DONUT is set by specifying inside and outside diameters. The inside diameter may be zero thereby making it a filled circle.

9. Hatch patterns

The HATCH command is used to fill up the area using a suitable pattern. The type of pattern and pattern variables can be chosen from a library of patterns available. The hatching will be carried out inside a closed defined area.

Tool Bar: **Menu** → **Draw** → **Hatch**

Command: **Hatch (H)**

Department of Mechanical Engineering

10. Text

Words, messages and numbers can be inserted as required on an engineering drawing. The alphanumeric keyboard is used extensively for non-graphical input such as text. The text style, height, text angle, aspect ratio, colour, etc. are some of the attributes associated with text. These attributes can be changed as per requirements.

11. Rectangle

Creates a rectangular polyline. With this command, the parameters (length, width, rotation) can be specified control the type of corners (fillet, chamfer, square).

Tool Bar: **Menu** → **Draw** → **Rectangle**

Command: **Rectang (R)**

Drafting Aids

1. Limits

Drawing limits are used to set the boundaries of the drawing. The drawing boundaries are usually set to match the size of a sheet of drawing paper. This means that when the drawing is plotted and a hard copy is made, it will fit on the drawing paper.

Fig : Page 67 : Engineering Graphics with AutoCAD 2020

Command: Limits

Specify lower left corner or [ON/OFF] <0,0>: Specify a point

Specify upper right corner or <12,9>: Specify a point

Note: Limits has no limit, it can be infinity with respect to paper size

2. Layers

A layer is like a clear piece of paper that can be laid directly over the drawing. We can draw on the layer and see through it to the original drawing. Layers can be made invisible, and information can be transferred between layers. Layers are used to control the visibility of objects and to assign properties such as color and linetype. Objects on a layer normally assume the properties of that layer.

Department of Mechanical Engineering

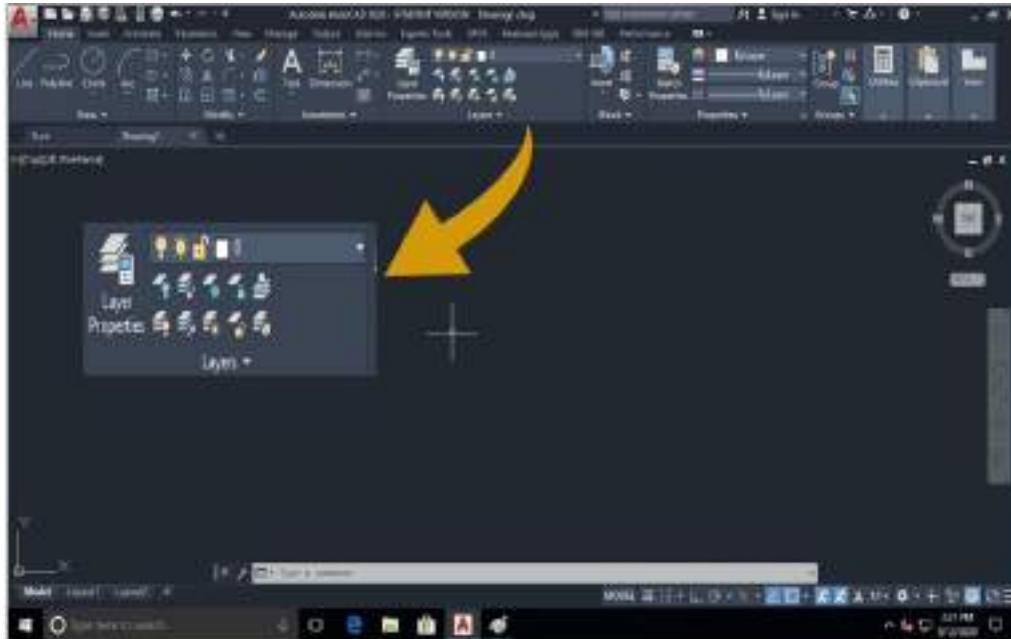

3. Dimensioning

Create several types of dimensions and save dimension settings by name.

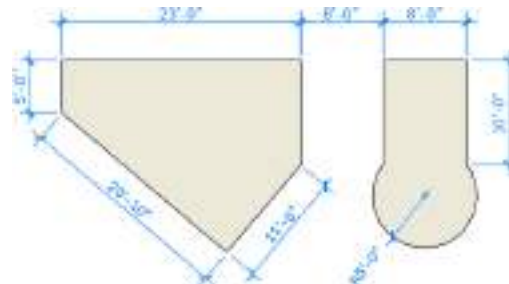

Linear Dimensions

horizontal, vertical, aligned, and radial dimensions can be created with the DIM command. The type of dimension depends on the object that is selected and the direction of dimension line.

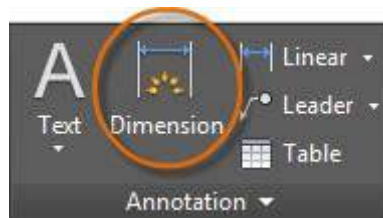

Dimension Styles

Dimension styles help establish and enforce drafting standards. There are many dimension variables that can be set with the DIMSTYLE command to control virtually every nuance of the appearance and behavior of dimensions. All these settings are stored in each dimension style. The

Department of Mechanical Engineering

default dimension style is named either Standard (imperial) or ISO-25 (metric). It is assigned to all dimensions until you set another style as the current dimension style.

The current dimension style name, Hitchhiker in this case, is displayed in the drop-down list of the Annotation panel.

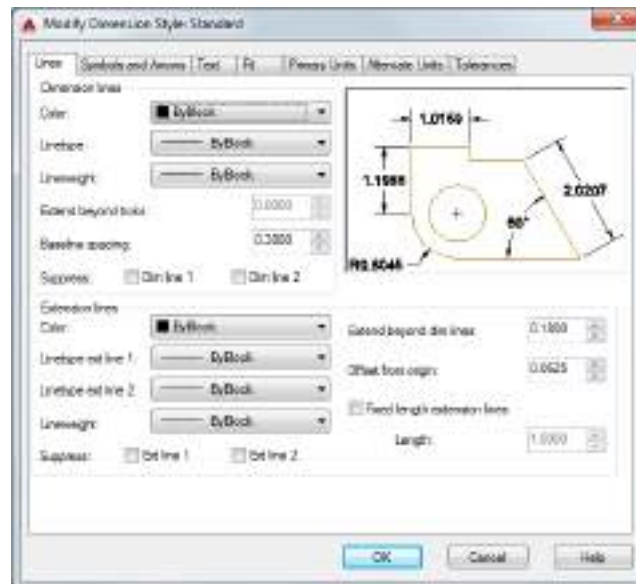

4. Object snap

Object snap provide a way to specify precise locations on objects whenever you are prompted for a point within a command. With running object snap(Osnap) settings, a snap point at an exact location on an object can be specified. When more than one option is selected, the selected snap modes are applied to return a point closest to the center of the aperture box.



Department of Mechanical Engineering

Object Snap ON (F3)

Turns running object snaps ON and OFF. The object snaps selected under Object Snap Modes are active while the Osnap mode is ON.

Object Snap Tracking On (F11)

Turns object snap tracking ON and OFF. With object snap tracking, the cursor can track along alignment paths based on other object snap points when specifying points in a command.

Object Snap Modes:

End Point

Snaps to the closest endpoint of an arc, elliptical arc, line, multiline, polyline segment, spline, region or to the closest corner of a trace. Solid or 3D face.

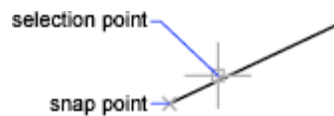

Midpoint

Snaps to the midpoint of an arc, ellipse, elliptical arc, line, multiline, polyline segment, region, solid, spline or xline.



Center

Snaps to the center of an arc, circle, ellipse, or elliptical arc.



Node

Snaps to a point object, dimension definition point, or dimension text origin.



Quadrant

Snaps to a quadrant point of an arc, circle, ellipse, or elliptical arc.



Intersection

Snaps to the intersection of an arc, circle, ellipse, line, multiline, polyline, spline, or xline and other geometrical objects. Extended intersections are not available as a running object snap.

Department of Mechanical Engineering



Extension

It causes a temporary extension line or arc to be displayed when the cursor is passed over the endpoint of objects, so that points can be specified on the extension.

Insertion

Snaps to the insertion point of an attribute, a block, a shape, or text.

Perpendicular

Snaps to a point perpendicular to the selected geometric object.

Deferred Perpendicular snap mode is automatically turned on when the object you are drawing requires that more than one perpendicular snap can be completed. An object such as a line, arc, circle, polyline, ray, xline, multiline, or 3D solid edge as an object from which to draw a perpendicular line can be used.



Tangent

Snaps to the tangent of an arc, circle, ellipse, elliptical arc, polyline arc, or spline. Deferred Tangent snap mode is automatically turned on when the object that is being drawn requires and complete more than one tangent snap. It can be used to draw a line or xline that is tangent to arcs, polyline arcs, or circles. When the cursor passes over a Deferred Tangent snap point, a marker and an AutoSnap tooltip are displayed.

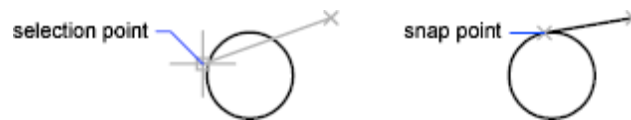

Apparent Intersection

Snaps to the visual intersection of two objects that do not intersect in 3D space but may appear to intersect in the current view.

Nearest

Snaps to the nearest point on an arc, circle, ellipse, elliptical arc, line, multiline, point, polyline, ray, spline or xline.

Parallel

Constraints a line segment, polyline segment, ray or xline to be parallel to another linear object. The parallel object snap is to be specified, after specifying the first point of a linear object. Unlike other object snap modes, the cursor must be moved and *hover* over another linear object until the angle is acquired. Then, move the cursor back toward the object that is to be created. When the path of the object is parallel to the previous linear object, an alignment path is displayed, which you can use to create the parallel object.

Department of Mechanical Engineering

Select All

Turns on all running object snap modes.

Clear All

Turns off all running object snap modes.

5. Zoom

The objects viewed in the drawing area can be zoomed in or out, and moved to see different portions of the sheet in detail by using the following commands:

The zoom flyout of standard tool bars has nine icons to opt.

- a) Zoom window: This command enlarges a rectangular area of a drawing based on a defined window using the cross hair
- b) Zoom all: This command displays the are of the drawing limits or extent whichever are greater.
- c) Zoom dynamic: Pans and zooms using a rectangular view box.
- d) Zoom scale: Zooms to change the magnification of a view using a scale factor.
- e) Zoom center: Zooms to display a view defined by a center point and a magnification value or a height.
- f) Zoom Object: Zooms to display one or more selected objects as large as possible and in the center of the view.
- g) Real Time: Zooms interactively to change the magnification of the view.
- h) Zoom extends: Zooms to display the maximum extents of all objects.
- i) Zoom Previous: Zooms to display the previous view. You can restore up to 10 previous views.

Out of these “Zoom window” and “Zoom all” command are more useful. Similarly, “Zoom real time”, “Pan real time” and “Zoom previous” commands are also frequently applied for drafting.

Department of Mechanical Engineering

Editing Commands (Modify Commands)

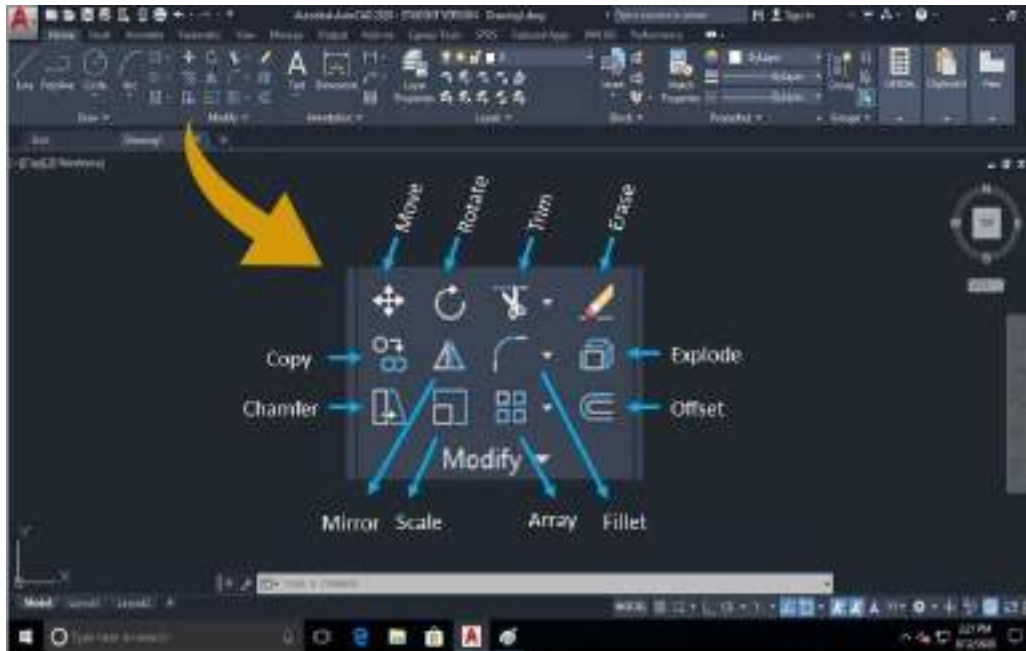

1. Move

The Move command works in a similar way to the COPY command except that no copy is made; the selected object(s) is simply moved from one location to another

Tool Bar: **Menu** → **Modify** →



Command: **explode**

2. Rotate

The Rotate command allows an object or objects to be rotated about a base point selected and the angle can be typed in the command prompt by the user.

Tool Bar: **Menu** → **Modify** →



Command: **explode**

3. Copy

The Copy command can be used to create one or more duplicates of any object(s) which have been previously created.

Tool Bar: **Menu** → **Modify** →



Command: **explode**

Department of Mechanical Engineering

4. Mirror

The Mirror command allows you to mirror selected objects in your drawing by picking them and then defining the position of an imaginary mirror line using two points. To create perfectly horizontal or vertical mirror lines turn the ORTHO command on.

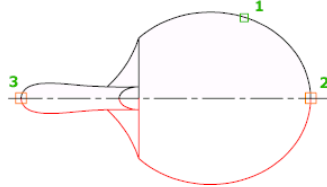

Tool Bar: **Menu** → **Modify** →



Command: **explode**

5. Array

The Array command makes multiple copies of a selected objects in a rectangular pattern (columns and rows) or a polar (circular) pattern or a along a path that is defined.

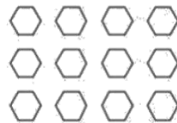

Rectangular

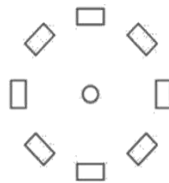

Polar

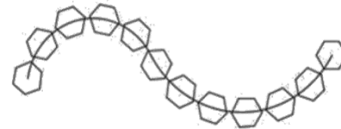

Path

Tool Bar: **Menu** → **Modify** →



Command: **explode**

6. Erase

The Erase command is one of the simplest AutoCAD commands and is one of the most used. The command erases or deletes any selected object(s) from the drawing.

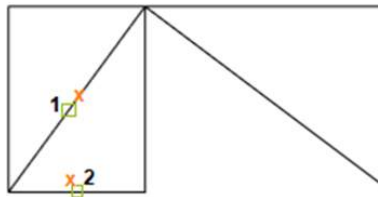

Selected lines before erasing

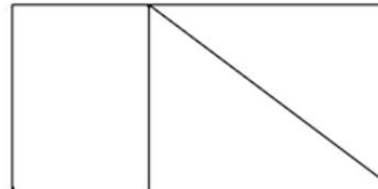

Removed lines after erasing

Tool Bar: **Menu** → **Modify** →



Command: **explode**

Department of Mechanical Engineering

7. Break

The Break command helps to break (remove a part of) an object by defining two break points.

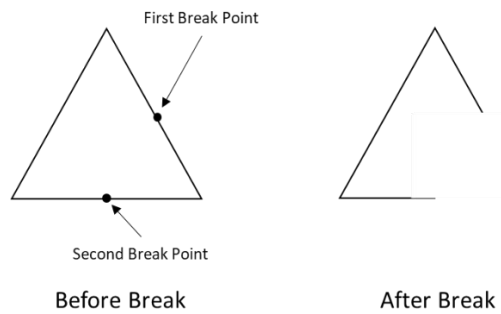

Tool Bar: **Menu** → **Modify** →



Command: **explode**

8. Fillet

The Fillet command is a very useful tool which allows to draw a tangent arc between two objects. The objects are usually intersecting. The objects do not have to intersect, but their separation cannot be more than the fillet radius.

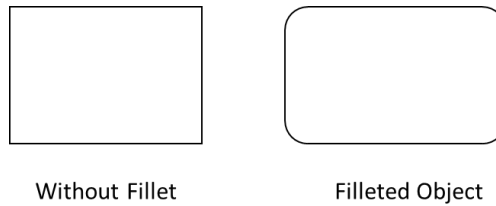

Tool Bar: **Menu** → **Modify** →



Command: **explode**

9. Chamfer

The Chamfer command creates an angled corner (Chamfer) between any two non-parallel lines or any two adjacent polyline segments. A chamfer is usually applied to intersecting lines.

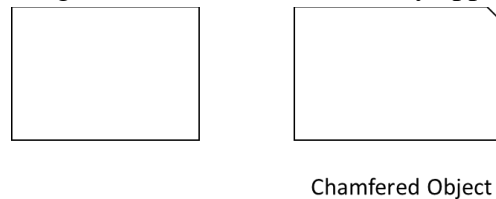

Tool Bar: **Menu** → **Modify** → **Fillet**



Command: **explode**

Department of Mechanical Engineering

10. Extend

The Extend command is used to extend a line, polyline or arc to meet an already existing object.

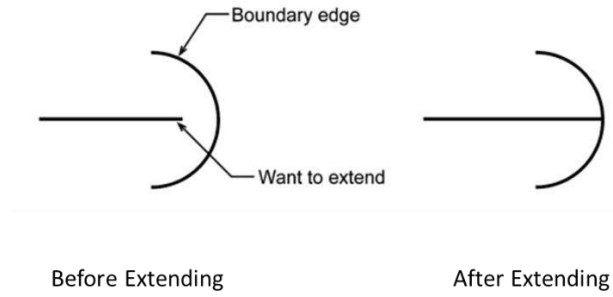

Before Extending Tool Bar: Menu → Modify → 	After Extending Command: explode
---	--

11. Offset

The OFFSET command creates a new object parallel to or concentric with a selected object. The new object is drawn at a user defined distance (the offset) from the original and in a direction chosen. The OFFSET command may only be used on one object or entity at a time.

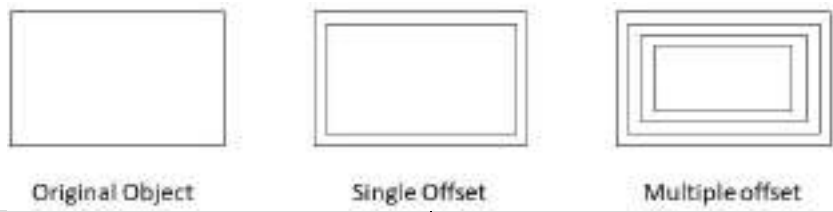

Original Object Tool Bar: Menu → Modify → 	Single Offset Command: explode
--	--

12. Stretch

The STRETCH command can be used to move one or more vertices of an object while leaving the rest of the object unchanged

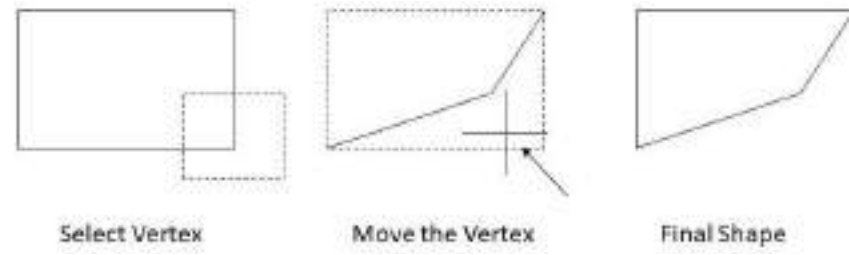

Select Vertex Tool Bar: Menu → Modify → 	Move the Vertex Command: explode
--	--

Department of Mechanical Engineering

13. Trim

The Trim command is used to trim off the part of an object that is not necessary. In order to trim an object, a second object which forms the cutting edge must be drawn. Cutting edges can be lines, xlines, rays, polylines, circles, arcs or ellipses.

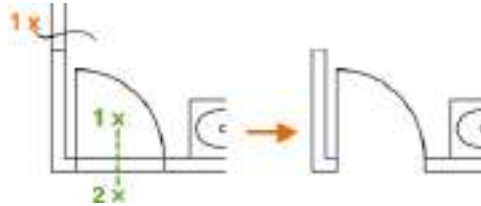

Tool Bar: **Menu** → **Modify** →



Command: **explode**

14. Scale

The Scale command can be used to change the size of an object or group of objects. It allows to shrink or enlarge the already existing drawing objects about a base point on specifying the scale factor.

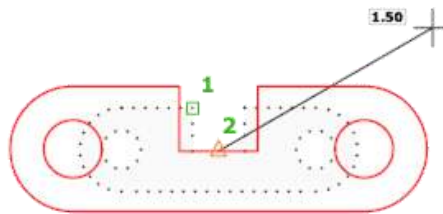

Tool Bar: **Menu** → **Modify** →



Command: **explode**

15. Explode

This command is used to break a single compound object into their constituent parts. In other words, a compound object explodes when the components to be modified separately. the command is used to return blocks, polylines, rectangles, etc.,

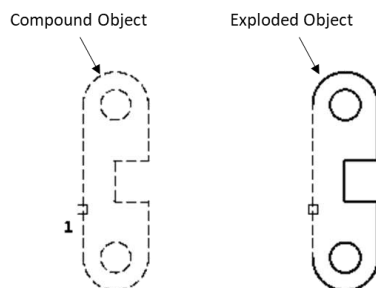

Department of Mechanical Engineering

Tool Bar: **Menu** → **Modify** → 

Command: **explode**

Department of Mechanical Engineering

Quick access toolbar

The Quick Access toolbar, displayed in the Drafting & Annotation workspace, is located at the very top of the drawing window next to the Application button. The Quick Access toolbar may be customized by adding or removing commands. This is done by right clicking on the toolbar and selecting Customize Quick Access toolbar or selecting the arrow at the end of the toolbar.

The Quick Access toolbar contains the following commands (reading left to right):

- QNew: Opens a new drawing.
- Open...: Opens an existing drawing. (Ctrl+O)
- Save: Saves the current drawing. (Ctrl+S)
- Save as: Allows you to save the current drawing under a different name. (Ctrl+Shift+S)
- Plot...: Plots or prints the current drawing. (Ctrl+P)
- Undo: Used to undo previous command or actions.
- Redo: Used to redo commands that have been undone

Starting a new Drawing

When starting a new drawing (QNEW), you have a choice of either starting from the *Create New Drawing* window or the *Select Template* window. The *Create New Drawing* window allows you to set up a drawing to your preferences. You may set parameters such as the units (Imperial or Metric), the size of the drawing, and the degree of precision. The *Select Template* window allows you to choose from predefined templates. Figure 2.5-1 shows both startup windows. The **STARTUP** variable is used to choose what is displayed when the application is started, or which window will appear when you start a new drawing. It has 4 values that may be set (i.e., 0, 1, 2, and 3). However, for starting a new drawing, only 0 and 1 are of interest. If **STARTUP** = 0, then the *Select Template* window will appear. If **STARTUP** = 1, then the *Create New Drawing* window will appear.

Template drawings store all the settings for a drawing and may also include predefined layers, dimension styles, and views. Template drawings are distinguished from other drawing files by the .dwt file extension. Several template drawings are included in AutoCAD®. You can make additional template drawings by changing the extensions of drawing file names to .dwt.

Department of Mechanical Engineering

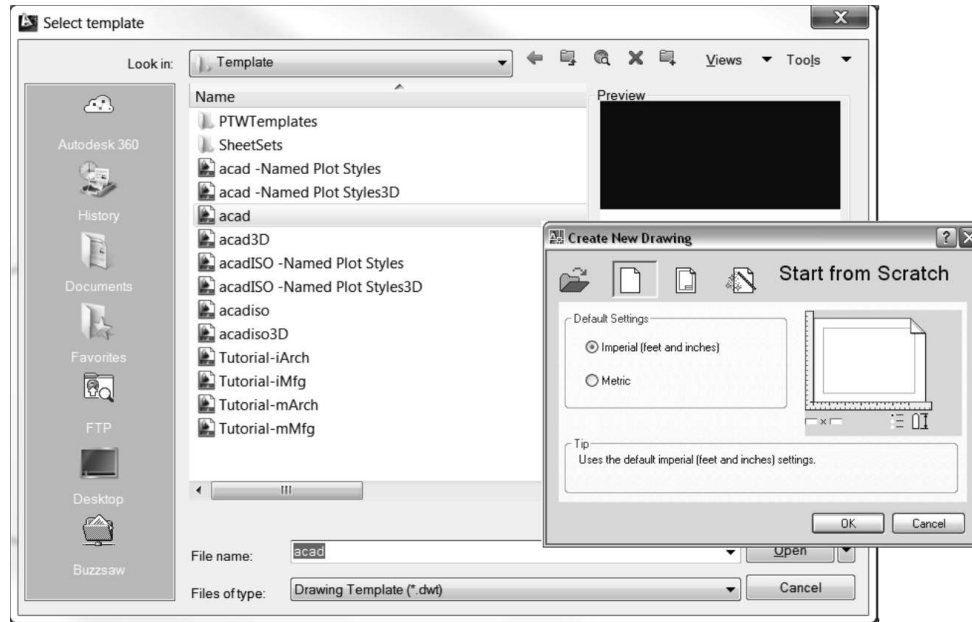

Starting a new drawing using the Create New Drawing window

Command: **startup**

Enter new value for STARTUP <0>: **1**

Quick Access toolbar or Application button: **File – New... (Ctrl+N)**. The Create New Drawing window will appear.

4) Create New Drawing window: Activate the **Start from Scratch** button, activate either Imperial

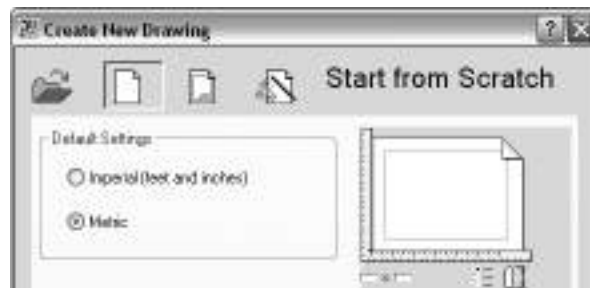

or Metric toggle, and then select OK

5) Quick Access toolbar:

6) Create New Drawing window:

- a. Activate the **Use a Wizard** button.
- b. Select a Wizard field: Select **Advanced Setup** and then **OK**.

Department of Mechanical Engineering



7) The wizard will take you through a setup which will allow you to choose your drawings nits, angle, angle measure, angle direction and drawing area.

Saving and opening a drawing

When saving (or open) a drawing (**Application** button - **Save** or **Saveas** or **Open**), you have the option of saving (or opening) the following file types.

- **DWG** (DraWinG) is a binary file format used for storing two- and three-dimensional design data and metadata. Most of what you draw will be saved in this format.
- **DWT** is a template file. These files are used as a starting point when starting a new drawing. They may contain drawing preferences, settings, and title blocks that you do not want to create over and over again for every new drawing.
- **DXF** (Drawing Interchange Format, or Drawing Exchange Format) is a CAD data file format developed by Autodesk® for enabling data interoperability between AutoCAD® and other programs.
- **DWS** is a standards file. To set standards, you create a file that defines properties for layers, dimension styles, linetypes, and text styles, and you save it as a standards file with the .dws file name extension.

Department of Mechanical Engineering

Plotting of Drawings

To print a drawing, click on the icon 'Plot'. This opens a dialogue box having two pages, namely 'Plot device and Plot Settings'.

The plotter configuration or its equivalent has to be selected in the Plot Device page. And the following options to be set in the Plot setting page

Page Size : A4 (210x297 mm) or A3 or etc.,

Units : Mm

Drawing Orientation : Portrait / Landscape

Plot Area : Limits

Plot Scale : 1:1

By clicking on the Full preview button, the area of the figure to printed will be projected. Click OK if it has a suitable orientation to start printing.

Department of Mechanical Engineering

Geometrical Constructions

Introduction:

Engineering drawing consists of a number of geometrical Constructions. A few methods are illustrated here without mathematical proofs.

1. To divide a straight line 65 mm into a given number of equal parts say 5.

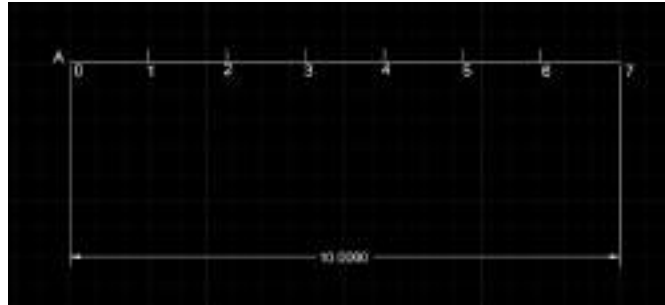

Solution

1. Draw a line of 65 mm with Command **L**
 2. Name the Line With Text Command **A,B**
 3. To Divide line Type Command **DIV** Enter
 4. Select Object To Divide Select Line
 5. Enter the Number Of Segment of 5 Enter
 6. Select Point Style from utilities to show divisions.
2. To bisect a given angle 90°

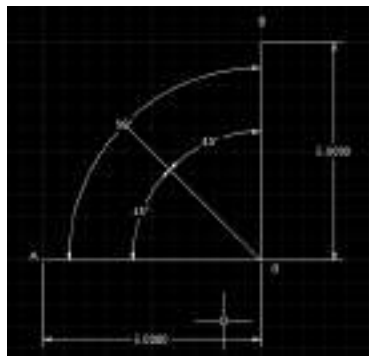

Solution

1. Draw a line of 50 mm with Command **L** Name the Line With Text Command **A,B**
2. Draw another Line 50 mm From the End of Previous Line with 90° Angle with Command **L** name the Line With Text Command **B,C**
3. To Bisect Line Type Command **XL** press enter
4. Select Bisect Option or Enter **B** and specify angle vertex point at End Point.

Department of Mechanical Engineering

5. Specify Angle Starting Point
6. Specify angle end point enter
7. Mention Angle After Bisection

Department of Mechanical Engineering**Polygons**

1. To construct a regular polygon (say a pentagon) given the length of the side 5 (EDGE METHOD)

Solution

1. To construct any polygon Enter Command **POL**
2. Enter No of Sides **5**
3. Specify Center of Polygon or Edge enter Command **E**
4. Specify First End Point of Edge & Specify second End Point of Edge by entering specific Distance **5**
5. Name the Edges With text Command **TEXT**

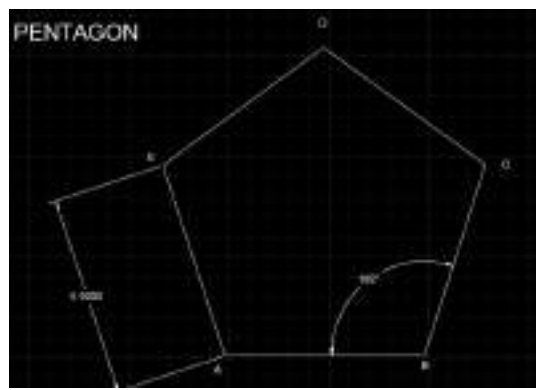

2. Inscribe a hexagon in a given circle of 50 mm Diameter (Inscribe Circle Method)

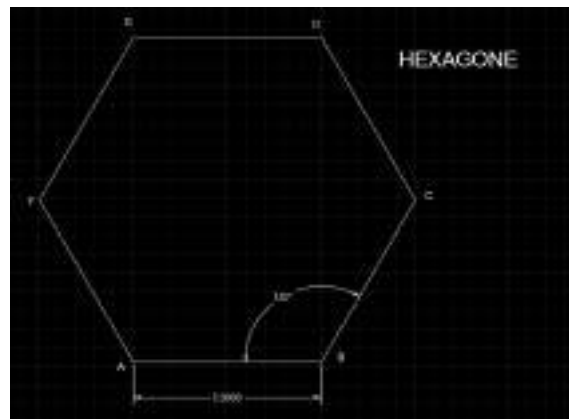

Department of Mechanical Engineering

Solution

1. To construct any polygon Enter Command **POL**
2. Enter No of Sides **6**
3. Specify Center pf Polygon or Edge enter select Center
4. Enter an option with Inscribed in Circle with command **I**
5. Specify radius Of Circle with 50
6. Name the Edges With text Command **TEXT**

Practice Exercises

1. Divide an 80 mm long straight line into five equal parts.
2. Divide a 90 mm long straight line into parts that are in proportion to 2:3:5.
3. Draw a perpendicular to a 100 mm long line AB, at a point P lying on the line at a distance of 40 mm from the end A.
4. Draw a 120 mm long line AB inclined at 60° to the horizontal. Erect a perpendicular to AB from point P, lying at a distance 30 mm from end A.
5. Draw perpendicular to a 100 mm long line AB, from a point P lying at a distance 60 mm from end A and 70 mm from end B.
6. Draw a line AB inclined at 30° to the horizontal. Draw another line CD parallel to and 50 mm away from AB.
7. Draw tangent to a circle of 40 mm diameter from any point P which is at a distance of 65 mm from the centre of the circle.
8. Two circles of radii 20 mm and 30 mm have their centres 65 mm apart. How many common tangents to both the circles are possible? Draw an internal and an external common tangent to these circles.
9. Two circles of radii 20 mm and 30 mm have their centres 50 mm apart. Draw all the possible common tangents to both the circles.
10. Two circles of radii 20 mm and 30 mm have their centres 40 mm apart. Draw a pair of common tangents to both the circles.
11. Draw a tangent to connect two circles of radii 25 mm and 40 mm. The centres of the circles are 15 mm apart.
12. Draw an arc of 30 mm radius connecting two straight lines inclined at 135° to each other.
13. Draw arc of 20 mm radius to connect a straight line AB and a circle of 30 mm radius, tangentially. The centre of the circle is at a distance 25 mm from AB. Consider the centres of the arc lies (a) within the circle (b) outside the circle.
14. Two circles have their centres 70 mm apart and radii 20 mm and 30 mm, respectively. Draw a circle of radius 25 lying internal to and connect both the circles tangentially.
15. Two circles have their centres 70 mm apart and radii 20 mm and 30 mm, respectively. Draw a circle of radius 65 lying external to and connect both the circles tangentially.

Department of Mechanical Engineering

16. Two circles have their centres 70 mm apart and radii 20 mm and 30 mm, respectively. Draw a circle of radius 55 which connects tangentially both the circles and (a) include 20 mm circle
(b) include 30 mm circle.
17. A point P is 40 mm from a line AB. Another point Q is in the AB and is 50 mm from the point P. Draw a circle passing through point P and tangential to the line AB at point Q.
18. Draw two possible circles to connect a given circle of 50 mm diameter AB and a point P, lying at a distance 70 mm and 25 mm from the ends of the diameter AB.
19. Inscribe a circle in a triangle of 75 mm, 65 mm and 55 mm long sides.
20. Draw a square of 60 mm long diagonals. Circumscribe another square on the square.
21. Draw regular pentagon, hexagon and a heptagon on a common edge of side 30 mm.
22. Draw a pentagon of 30 mm side with a side vertical. Attach a non-overlapping hexagon of same side length with common vertical edge.
23. Construct a heptagon of edge length 30 mm. Construct a pentagon of same edge length inside the heptagon with one edge of the polygons being common.
24. Draw an octagon of 25 mm side keeping one of the sides vertical.
25. Draw five circles in a given circle of 80 mm diameter, each touching the given circle and the other two circles.
26. Draw five circles inside the pentagon of 30 mm side, such that each circle touches one side of the pentagon and two other circles.
27. Draw five circles inside the pentagon of 30 mm side, such that each circle touches two sides of the pentagon and two other circles.
28. Draw three circles inside a hexagon of 30 mm side, such that each circle touches one side of the hexagon and two other circles.
29. Draw five circles outside the pentagon of 20 mm side, such that each circle touches one side of the pentagon and two other circles.
30. Draw six circles outside a given circle of 30 mm diameter, such that each circle touches the given and two other circles.

Department of Mechanical Engineering



UNIT 2

ORTHOGRAPHIC PROJECTIONS



Projections

Projection

As per the optical physics, projection is a process of causing an image by rays of light taken in a particular direction from an object to a picture plane. The imaginary ray of light between the object and the projection plane is called line of sight or projector.

Orthographic Projection

In orthographic projection, the projectors are parallel and perpendicular to the plane of projection. Orthographic projections on mutually perpendicular projection planes will fully describe the object in its shape and size. Hence, all design and manufacturing drawings are made with orthographic projections.

Projectors \perp to the Projection plane

Vertical Plane and Front Elevation

A view looking from the front is projected onto the vertical plane. This view is called front view or front elevation and shows the width and height dimensions. A vertical plane of projection, which is behind the object in relation to the observer, is shown in figure below.

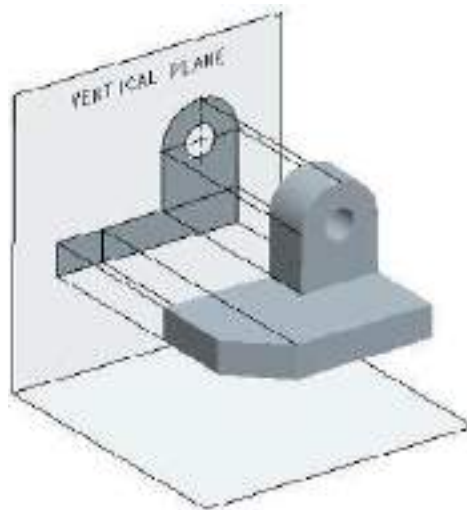

Horizontal Plane and Top View

A view looking from the top is projected onto the horizontal plane placed below the object. This view is called top view or plan. Top view shows the width and depth dimensions of an object. A horizontal plane with a top view is shown in figure below.

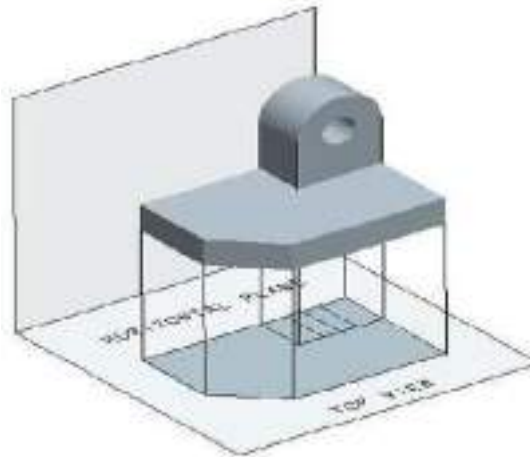

Profile Plane and End View

A view looking from the side of an object is projected onto the profile plane. The observer and the projection plane are on different sides of the object (i.e.) the object is between the observer and the projection plane. The viewing can be from the right or the left side of the object. The view drawn looking the object from the right is called right side view or right end elevation. The view looking the object from the left is called left side view or left end elevation. Side view of an object shows the depth and height dimensions. A profile plane with a left side view is shown in figure below.

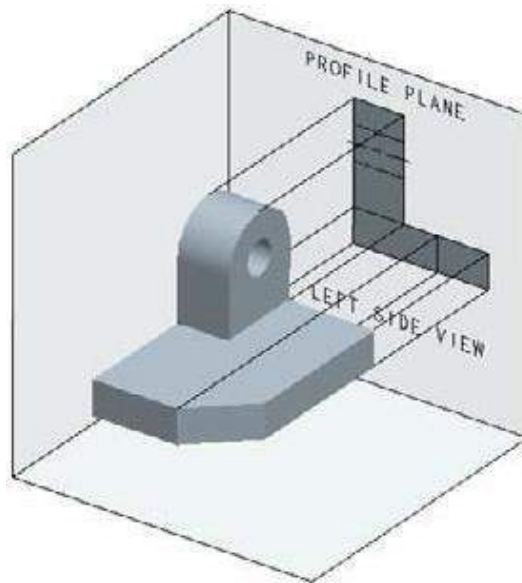

First Angle Projection

An arrangement of vertical, horizontal, and profile planes and quadrants used to draw first angle projections is shown below. Front view is projected onto the vertical plane, top view onto the horizontal plane, and side view onto the profile plane.

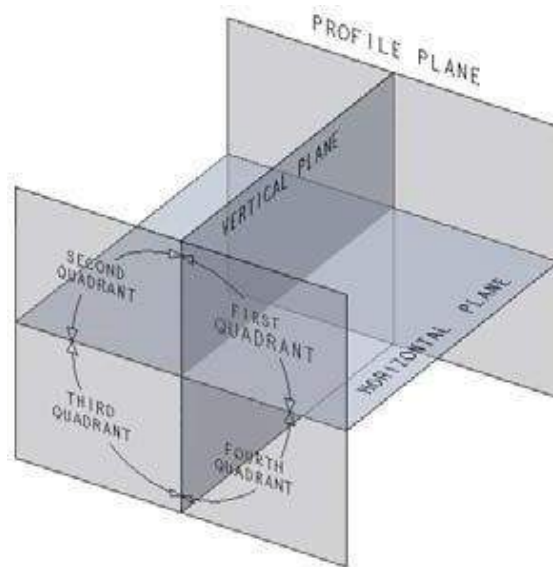

Projection in First Angle

An object placed in the first quadrant. The vertical plane is behind the object, horizontal plane below the object, and profile plane to right of the object. The views with the corresponding planes are shown in figure. The top view is seen below the elevation and left side view is seen on the right of front view. This is the arrangement of views in the first angle projection.

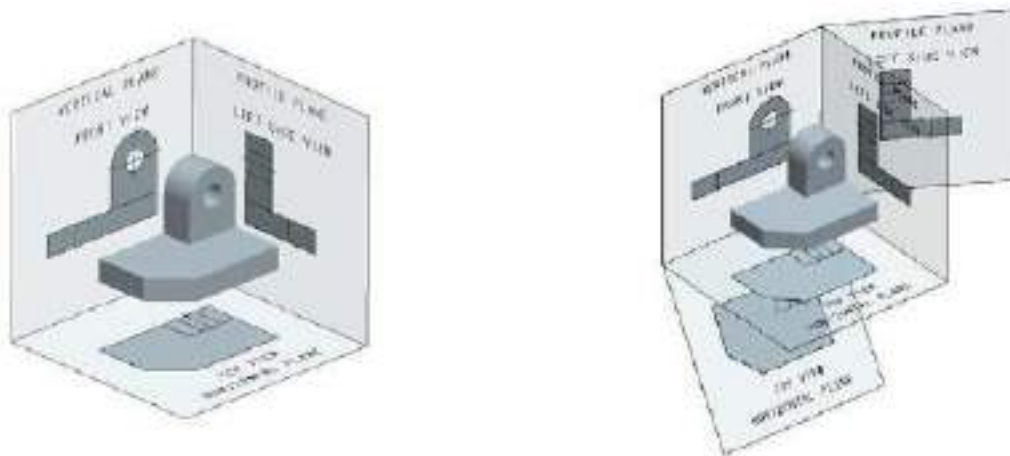

Projection in Third Angle:

An object placed in the third quadrant. The vertical plane is in front of the object, horizontal plane above the object and profile plane to the left of the object. The views with corresponding planes are shown in figure. Top view is above the front view and left side view is to the left of the front view. This is the arrangement of the views in third angle projection.

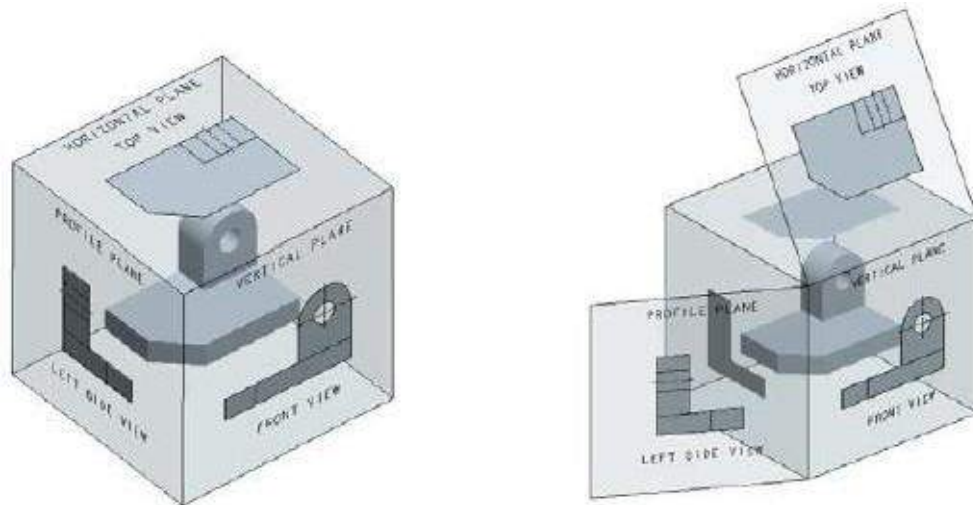

Multiview Projection

It consists of a set of two or more orthographic views of an object taken from different directions, which are mutually perpendicular. These views are arranged relative to each other in a particular way. Each of these views shows the shape of the object for a particular view direction. Multiple views collectively describe the object completely and exactly. Hence, multiview projections are used in engineering to describe the true shape of any object.

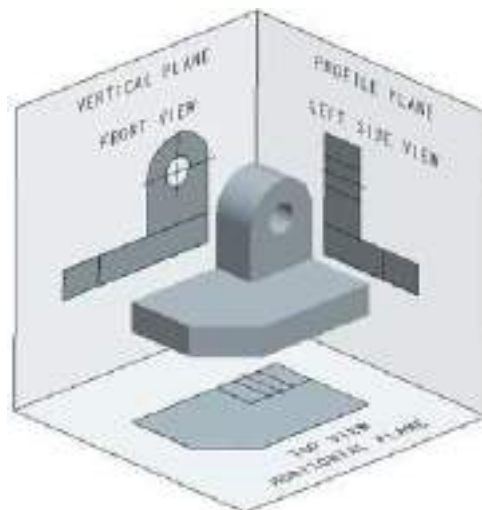

Projections of Points

Point

A point usually represented by a dot is a dimensionless geometrical entity that has a position but no magnitude. Whereas in computer aided engineering drawing the point has dimension but it is not considered or neglected. A point is obtained wherever two straight or curved lines intersect each other.

Projection of Points

Projection of points in various quadrants is the basis for projection of lines, projection of planes and projection of solids. In a conventional coordinate system, the position of a point in space is denoted by its three coordinates i.e., x, y and z.

In projections, two principal planes are used to get the projection of an object that is vertical plane and horizontal plane, the vertical plane denoted by (V.P.) and horizontal plane denoted by (H.P.) as shown in Fig. They intersect each other at right angles and the line of intersection is known as axis of the plane. The vertical plane of projection is always in front of the observer and the projection on this plane is known as front view or elevation. The other plane is the horizontal plane of projection and the projection on this plane is called the top view or plan.

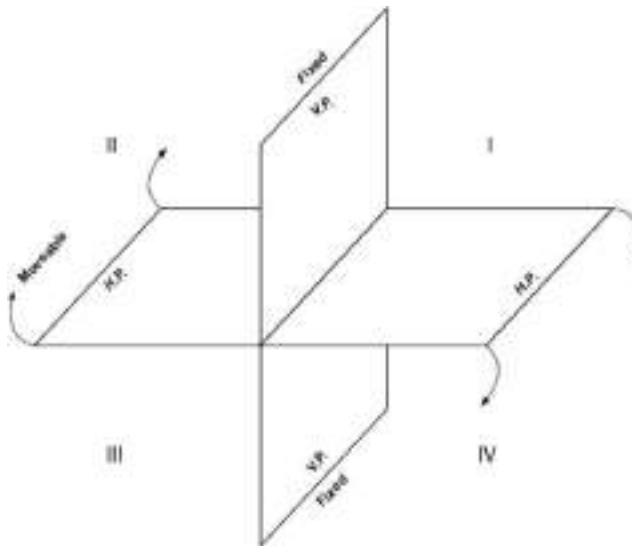

Pictorial view of Principal Planes

The view obtained by viewing object from right side is called right side view or right end view. A plane perpendicular to both H.P. and V.P. is called profile plane (P.P). The right side view is always on the right to the front view. If the object is viewed from left on profile plane then the view is known as left side view or left end view.

Position of Points in Various Quadrants

1. When point is in First Quadrant

When a Point P is situated in I quadrant i.e., above H.P. and in front of V.P. , Its front view (p') will be above XY line and its top view (p) will be below the XY line.

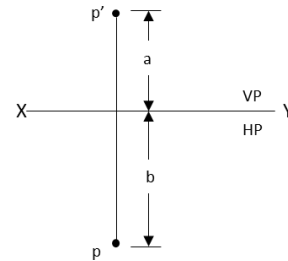
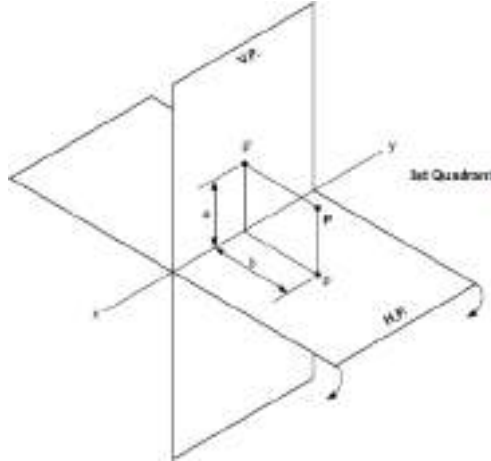

2. When point is in Second Quadrant

When a Point P is situated in II quadrant i.e., above H.P. and behind V.P. , Its front view (p') will be above XY line and its top view (p) will also be above the XY line.

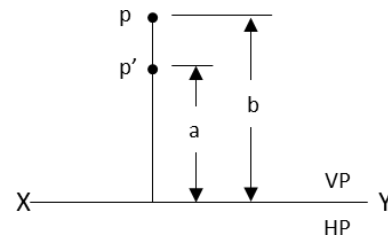
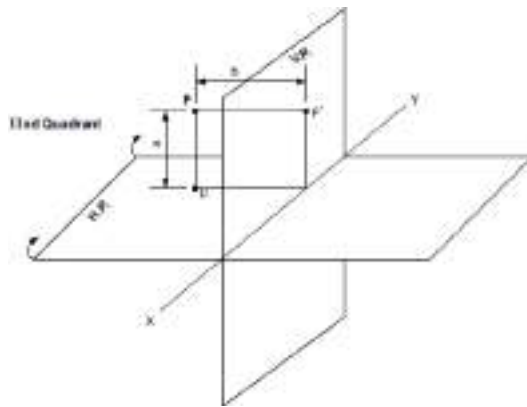

3. When point is in Third Quadrant

When a Point P is situated in III quadrant i.e., below H.P. and behind of V.P. , Its front view (p') will be below XY line and its top view (p) will be above the XY line.

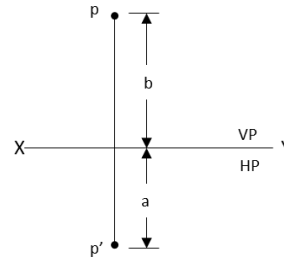
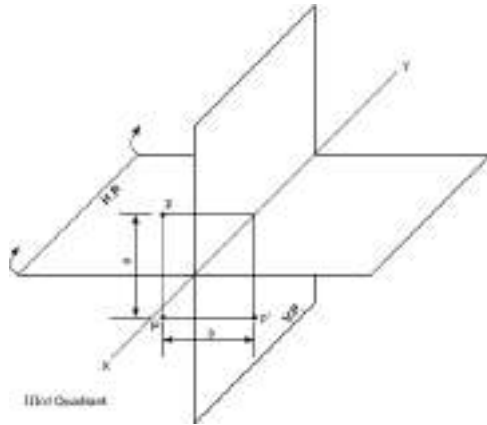

4. When point is in Fourth Quadrant

When a Point P is situated in IV quadrant i.e., below H.P. and in front V.P. , Its front view (p') will be below XY line and also its top view (p).

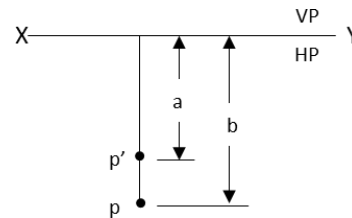
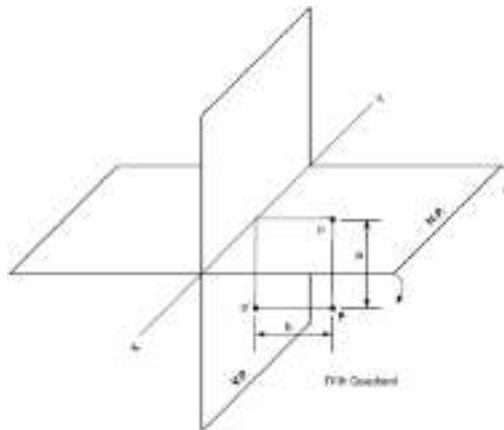

Positions of geometrical entities in various quadrants of the projections

When	Position		Quadrant	Front View	Top View
	VP	HP			
Point is	Infront	Above	I	Above XY	Below XY
Point is	Behind	Above	II	Above XY	Above XY
Point is	Behind	Below	III	Below XY	Above XY
Point is	Infront	Below	IV	Below XY	Below XY
Point is	Infront	In or on	I or IV	On XY	Below XY
Point is	In or on	Above	I or II	Above XY	On XY
Point is	Behind	In or on	II or III	On XY	Above XY
Point is	In or on	Below	III or IV	Below XY	On XY
Point is	In or on	In or on	I, II, III, or IV	On XY	On XY

System of Notation

1. The actual points in space are denoted by capital letters A, B, C etc.
2. The front view (FV) of the points are denoted by their corresponding lower-case letters withdashes as a', b', c', etc.
3. The top view (TV) of the points are denoted by their corresponding lower-case letters withoutdashes as a, b, c etc.
4. The side view (SV) of the points are denoted by their corresponding lower-case letters withdouble dashes as a", b", c" etc.
5. Projectors are always drawn as continuous thin lines and Points with Dot.

In Computer Aided Engineering Graphics for projection of points following commands are used other than evoking software, opening file, saving file and giving print command. Using these minimum nine commands any type of projection of point problem can be solved they are as follows:

1. Select tool Command.
2. Point command.
3. Poly-line command.
4. Two point line command.
5. Parallel line command.
6. Bisector command.
7. Smart dimension command.
8. Line width command.
9. Insert text command.

Solved Problem:

1. Draw the projections of the following points on the same ground line, keeping the projectors 25 mm apart.
 - i. A is in the H.P. and 20 mm behind the V.P.
 - ii. B is 40 mm above the H.P. and 25 mm in front of the V.P.
 - iii. C is in the V.P. and 40 mm above the H.P.
 - iv. D is 25 mm below the H.P. and 25 mm behind the V.P.
 - v. E is 15 mm above the H.P. and 50 mm behind the V.P.
 - vi. F is 40 mm below the H.P. and 25 mm in front of the V.P.
 - vii. G is in both the H.P. and the V.P.

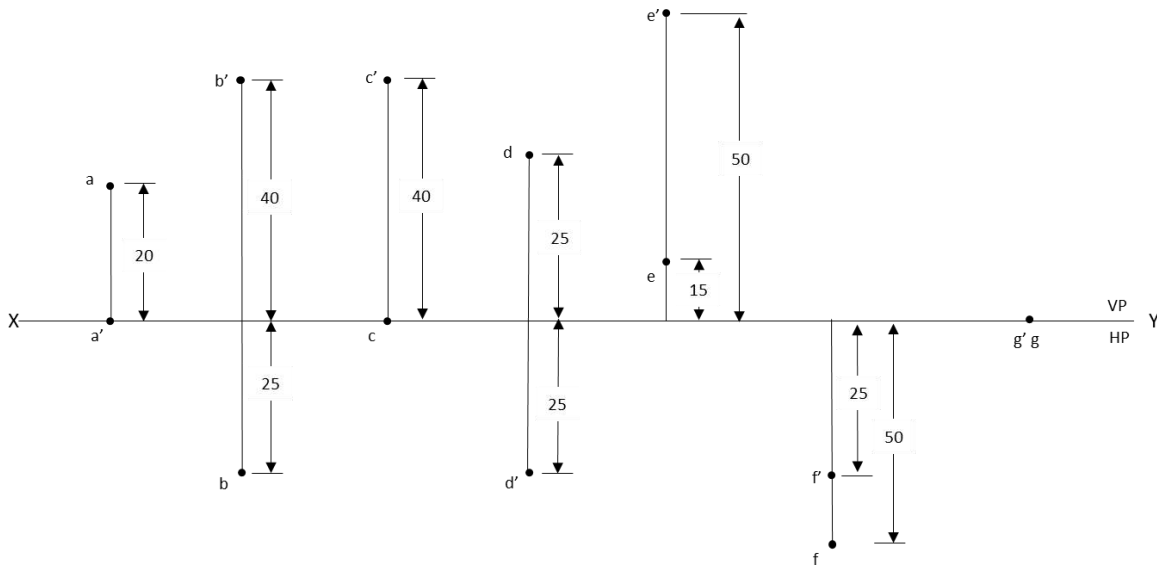
**Solution**

1. Open the Software. Click on the Application Menu and click on New and select “acad” in the open dialog box and click Open.
2. Enter the command “UNITS” in command bar and Select units as “Millimeters and click ok.
3. Enter the command “LIMITS” in command bar and enter 0,0 click enter and enter upper right corner as 120,90 and click enter
4. Enter the command “ZOOM” in command bar and enter A and click enter
5. As per the problem ,draw a XY line by using Xline command. Mark VP and HP above and below it by using “XTEXT” command in command bar
6. Divide the line into some equal parts depend upon how many points given.
7. Draw the lines representing the Projectors as per the dimensions mentioned in the problem and mark the front and top views of the points using **Point** command.
8. Mention the dimensions for all points from the XY line using **dimlinear** command

Practice Problems

1. Draw the orthographic projections of the following points.
 - i. Point P is 30 mm. above H.P and 40 mm. in front of VP.
 - ii. Point Q is 25 mm. Above H.P and 35 mm. behind VP.
 - iii. Point R is 32 mm. below H.P and 45 mm behind VP.
 - iv. Point S is 35 mm. below H.P and 42 mm in front to VP.
 - v. Point T is in H.P and 30 mm behind VP.
 - vi. Point U is in V.P and 40 mm. below HP.
 - vii. Point V is in V.P and 35 mm. above H.P.
 - viii. Point W is in H.P and 48 mm. in front of VP.

2. Draw the projections of the following points on the same XY line, keeping convenient distance between each projectors. Name the quadrants in which they lie.
 - i. Point A is 30 mm above HP and 35 mm in front of VP.
 - ii. Point B is 35 mm above HP and 40 mm behind VP.
 - iii. Point C is 40 mm above HP and on VP.
 - iv. Point D is 35 mm below HP and 30 mm in front of VP.

3. Draw the projections of the following points on the same XY line, keeping convenient distance between each projectors. Name the Quadrants in which they lie.
 - i. Point E is 30 mm below HP and 25 mm behind VP.
 - ii. Point F is 35 mm below HP and 30 mm in front of VP.
 - iii. Point G is on HP and 30 mm in front of VP.
 - iv. Point H is on HP and 35 mm behind VP.

Projection of Straight Lines

Introduction

A line may be defined as the locus of a point moving along a fixed path. A line consists of a number of points; its projections are drawn by joining the projection of its extreme (end) points. Hence, the projections of a straight line may be drawn by joining the respective projections of its ends, which are points. In a conventional drawing, a line has only length but no thickness. Whereas in computer aided engineering graphics the line has length and thickness.

The position of a straight line may have different orientations in space. As per first angle projection, it may be parallel, perpendicular or inclined to either or both the Reference planes (horizontal or vertical planes) as mentioned in the below classification.

Classification of Line Positions

A line may be placed in infinite number of positions with respect to the reference planes. These positions may be classified according to the inclination of the line to reference planes and the quadrants in which it is placed.

1. Line parallel to both the reference planes (HP & VP)
 - (a) Line away from both HP and VP.
 - (b) Line in HP and away from VP.
 - (c) Line in VP and above HP.
 - (d) Line on both HP and VP.

2. Line perpendicular to either of reference planes (HP or VP)
 - (a) Line perpendicular to HP and away from VP.
 - (b) Line perpendicular to HP and on VP.
 - (c) Line perpendicular to VP and above HP.
 - (d) Line perpendicular to VP and on HP.

3. Line inclined to HP and parallel to VP
 - (a) Line inclined to HP, parallel to VP and away from VP.
 - (b) Line inclined to HP, parallel to VP and in VP.

4. Line inclined to VP and parallel to HP
 - (a) Line inclined to VP, parallel to HP and away from HP.
 - (b) Line inclined to VP, parallel to HP and in HP.

5. Line inclined to both HP and VP
 - (a) One end of line in HP and the other end away from VP.
 - (b) One end of line in VP and the other end away from HP.

- (c) One end above HP and the other end away from VP.
- (d) One end away from VP and the other end above HP.
- (e) One end in HP and VP and other end away from HP and VP.
- (f) Both ends on HP and VP.

System of Notation

1. The actual line in space is denoted by capital letters A and B, or C and D etc.
2. The front view (FV) of a line is denoted by their corresponding lower letters with dashes as a' and b', c' and d' etc.
3. The top view (TV) of a line is denoted by their corresponding lower case letters without dashes as a and b, c and d etc.
4. The side view (SV) of a line are denoted by their corresponding lower case letters with double dashes as a'' and b'', c'' and d'' etc.
5. Projectors are always drawn as continuous thin lines.
6. Line with specific thickness for a particular type of line.

Solved Problems

1. Draw the projections of a 75 mm long straight line, in the following positions:
 - i. Parallel to both the H.P. and the V.P. and 25 mm from each.
 - ii. Perpendicular to the H.P., 20 mm in front of the V.P. and its one end 15 mm above the H.P.
 - iii. Inclined at 30° to the H.P. and its one end 20 mm above it; parallel to and 30 mm in front of the V.P.

- i. Parallel to both the H.P. and the V.P. and 25 mm from each.

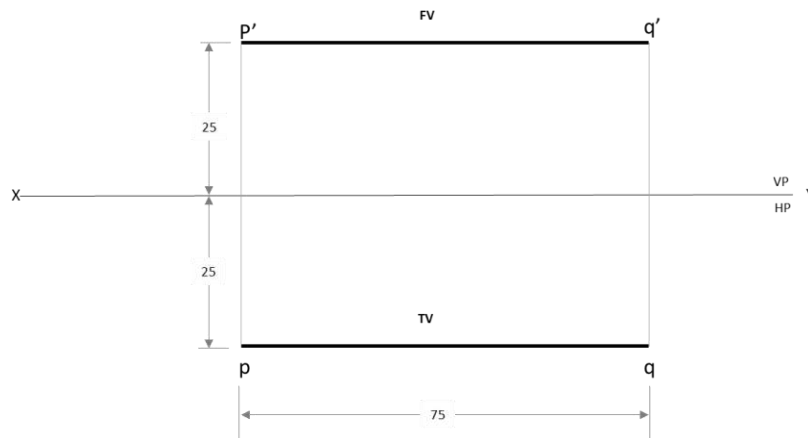

Solution:

1. Draw XY line Using Xline Command.
 2. Mark the annotations X, Y, VP, HP to the line drawn by using INSERT TEXT command from drafting tool bar. This must be done just by typing and inserting at the required positions using the left click of the mouse.
 3. According to question 75 mm line Parallel and 25 mm from HP put the Point 25 mm from above XY line by Using Point Command Name the Point with p'
 4. As per the problem, mark points p, q, p' and q' according to the dimensions given on both side of XY line.
 5. Draw a line of 75 mm that is parallel and above XY from point p' to q' by using Text command.
 6. Draw another line of 75 mm parallel line and below XY from point p to q by using Text command
 7. Mention the Dimensions by using **DIMLINEAR** Command.
- ii. Perpendicular to the H.P., 20 mm in front of the V.P. and its one end 15 mm above the H.P.

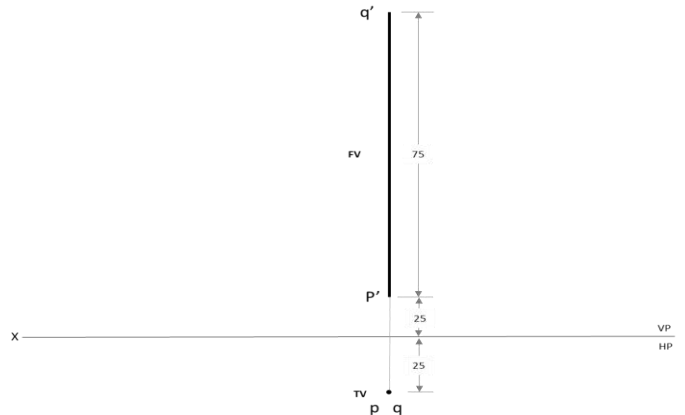
**Solution:**

1. Draw XY line By Using Line Command **L** and Name with X,Y at two ends By Using Text Command
2. According to question 75 mm line perpendicular to HP and 15 mm above HP. put the Point 15 mm from above XY line by Using Point Command Name the Point with p'
3. Line Parallel to and 25 mm in front of VP Put the point 25 mm below the XY line by using Point Command. Name the Point with p.
4. Draw 75 mm perpendicular line from p'. Name the end point q' by using Text command
5. When line Perpendicular to HP & Parallel to VP in top view Line Like Point its two end points on the same point then mention q on the same point 25 below XY line
6. Mention the Dimensions by using **DIMSTYLE** Command.

- iii. Inclined at 30° to the H.P. and its one end 20 mm above it; parallel to and 30 mm in front of the V.P.

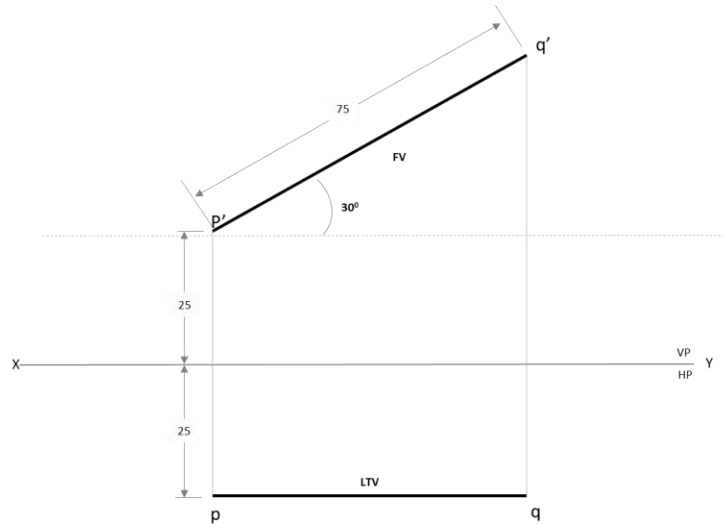

Solution:

1. Draw XY line By Using Line Command **L** and Name with X,Y at two ends By UsingText Command
2. According to question 75 mm line 30° inclined and 20 mm above the H.P put the Point 20 mm from above XY line by Using Point Command Name the Point with p'
3. Line Parallel to and 30 mm in front of VP Put the point 30 mm below the XY line by using Point Command. Name the Point with p.
4. Draw 75 mm linen from p' with inclination of 30° . Name the end point q' by using Text command Name it F.V
5. When line Inclined to HP & Parallel to VP in top view Line will be reduced Draw Perpendicular line from q' to locus of p name the intersection point as q & Name the reduced line as Length of Top View (LTV).
6. Mention the Dimensions by using **DIMLINEAR** Command.

2. A line AB 80 mm long has its end A 20 mm above the HP and 30 mm in front of VP. It is inclined at 30° to HP and 45° to VP. Draw the projections of the line.

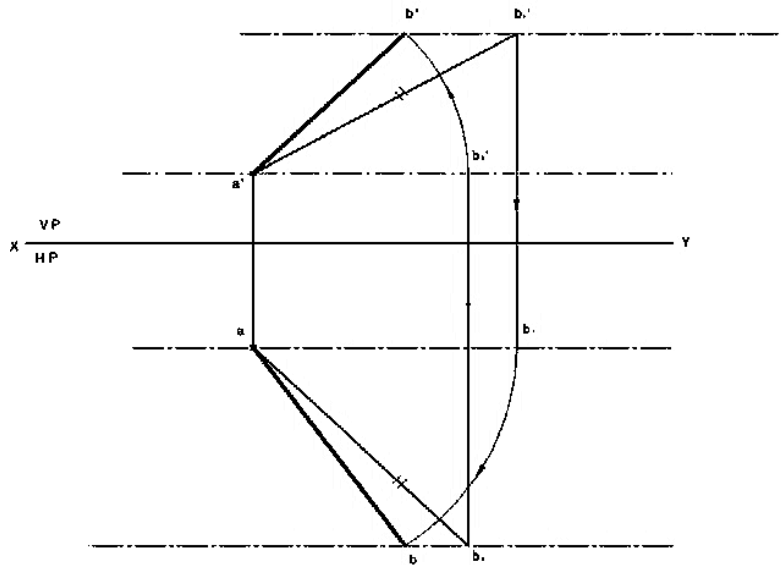

Solution:

1. Draw XY line By Using Line Command **L** and Name with X,Y at two ends By Using Text Command
2. According to question 80 mm line 30° inclined and 20 mm above the H.P put the Point 20 mm from above XY line by Using Point Command Name the Point with p'
3. Draw 80 mm line from p' with inclination of 30° . Name the end point q1' by using Text command
4. According to question 80 mm line 45° inclined and 30 mm in front of V.P put the Point 30 mm from above XY line by Using Point Command Name the Point with p
5. Draw 80 mm line from p with inclination of 45° . Name the end point q2 by using Text command
6. Draw perpendicular line from q1' to locus of p name it As q1. Draw another Perpendicular line from q2 to locus of p1 name the intersection point as q2'
7. Name p'q2' Line as LFV and Name pq1 line as LTV.
8. For Final front View take P' as center p'q2' line as radius draw arc which will intersect Locus of P' at q' Join p'q' LINE it as FFV
9. For Final Top View take P as center p'q1' line as radius draw arc which will intersect Locus of P at q Join p q line it as FTV
10. Mention the Dimensions by using **DIMLINEAR** Command.

Practice Problems:

1. The top view of a line AB, 80 mm long measures 65 mm and the length of the front view is 50 mm. The end A is on HP and 15 mm in front of VP. Draw the projections
2. Line AB has its end A 20 mm above the HP and 15 mm in front of the VP. The other end B is 60 mm above the HP and 45 mm in front of VP. The distance between end projectors is 70 mm. Draw its projections. Determine the apparent lengths and true inclinations.
3. A line has its end A 10 mm above HP and 15 mm in front of VP. The end B is 55 mm above HP and line is inclined at 30° to HP and 35° to VP. The distance between the end projectors is 50 mm. Draw the projections of the line. Determine the true length of the line and its inclination with VP.
4. A line CD 60mm long has its end 'C' in both H.P. and V.P. It is inclined at 30° to H.P. and 45° to V.P. Draw the projections.
5. A point C is 40mm below H.P. and 20mm behind V.P. another points D and E are 60mm above H.P. and in front V.P., 90mm below H.P. and 45mm in front of V.P. respectively. Draw the projections of all points on same reference line.
6. The end P of a straight line PQ is 20 mm above the H.P. and 30mm in from V.P. The end Q is 15mm below the H.P. and 45mm behind the V.P. If the end Projectors are 50mm apart, Draw the Projection of PQ and determine the true length, traces and inclination with the reference planes.
7. The front view of line inclined at 30° to V.P. is 65mm long. Draw the projections of a line, when it is parallel to and 40mm above H.P. and one end being 20mm in front of V.P.
8. Line PQ has 72mm length in the front view and 66mm length in the top view. The end P is 48mm below HP and 40mm behind VP, while the end Q is 12mm below HP. Draw the projection of the line, locate the traces and determine the true length and inclinations of the line with the reference planes.



UNIT 3

PROJECTIONS OF PLANES & SOLIDS



Projection of Planes

Introduction

A plane is a two-dimensional geometrical entity. It has length and width but no thickness. For practical purposes, a flat face of an object may be treated as a plane. A plane which has limited extent is termed as a lamina.

A plane can be located by:

- (i) Three non-collinear points,
- (ii) A straight line and a point outside it,
- (iii) Two parallel or intersecting straight lines, or
- (iv) Traces of the lines.

This chapter deals with the projections of laminas of pre-defined shapes, e.g., triangular plane, square plane, rectangular plane, pentagonal plane, hexagonal plane, circular plane, semicircular plane, etc. Sometimes, a given plane is composed of two or more planes mentioned above. Such planes are called composite planes, e.g., plane composed of a half hexagon and a semicircle, circular plane with hexagonal hole, etc.

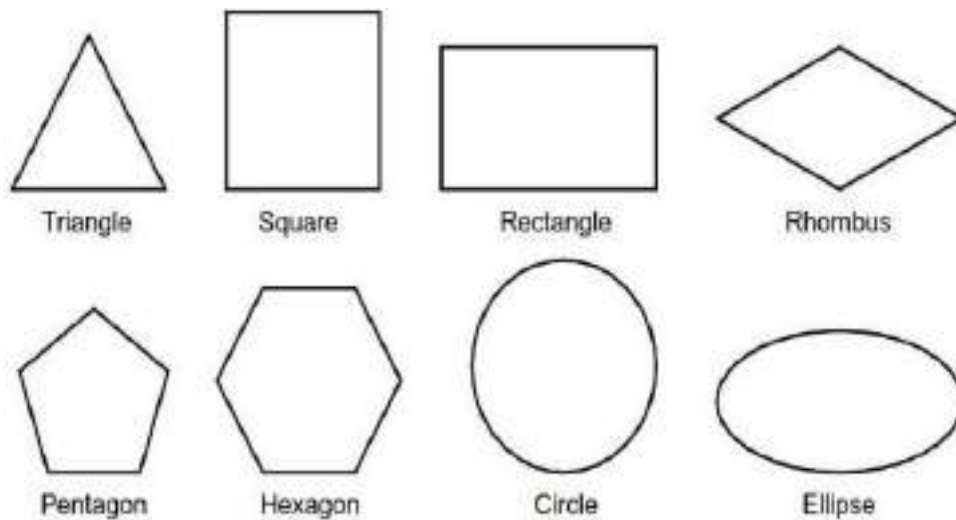

Planes

Positions of Planes

1. Plane parallel and perpendicular to reference planes (HP & VP)
 - A. Plane parallel to HP and perpendicular to VP.
 - B. Plane parallel to VP and perpendicular to HP.
2. Plane perpendicular and inclined to reference planes (HP & VP)
 - A. Plane perpendicular to HP and inclined to VP.
 - B. Plane perpendicular to VP and inclined to HP.
3. Plane perpendicular to both HP & VP.
4. Plane inclined to both HP & VP
 - A. Inclination to HP and VP is not equal to 90° .
 - B. Inclination to HP and VP is equal to 90° .

Terms Used in Projections of Planes

The following terms must be understood before we proceed for the step-by-step procedure of obtaining the projections of a plane.

True Shape: The actual shape of a plane is called its true shape.

Inclination with the RPs: The inclination of a plane with an RP is the acute angle the plane makes with that RP. It is always measured in a plane perpendicular to the given plane and the RP.

Inclination with the HP (θ_p) It is the acute angle the plane makes with the HP.

Inclination with the VP (ϕ_p) It is the acute angle the plane makes with the VP.

Traces of the Plane: Just like a line, a plane also has traces. The traces of a plane are the lines of intersections of the plane with the RPs. A plane may have a horizontal trace or vertical trace or both.

Horizontal Trace (HT) The real or imaginary line of intersection of a plane with the HP is called horizontal trace of the plane. HT is always located in the TV.

Vertical Trace (VT) The real or imaginary line of intersection of a plane with the VP is called vertical trace of the plane. VT is always located in the FV.

It should be noted that the plane has no trace on the RP to which it is parallel. For example, a plane parallel to the HP will have no HT. Similarly, a plane parallel to the VP will have no VT. HT and VT of a plane (produced if necessary) meet at a point on the XY.

Perpendicular Planes: The planes perpendicular to one or both the RPs are called perpendicular planes. The first three positions of the planes mentioned in the previous section represent perpendicular planes.

Oblique Planes: The planes inclined to both the RPs are called oblique planes. The fourth position of the planes mentioned in the previous section represents oblique planes.

Line View or Edge View: The view of a plane seen as a line is called line view or edge view of the plane. One view of a perpendicular plane is always an edge view. The edge view always represents the trace of the plane. For example, if a plane is perpendicular to the VP, then its FV will be an edge view representing VT of the plane. Similarly, TV of a plane perpendicular to the HP Will be an edge view representing HT.

System of Notation

1. The actual plane in space is denoted by capital letters A, B, C and D etc.
2. The front view (FV) of a plane is denoted by their corresponding lower-case letters withdashes as a', b', c' and d' etc.
3. The top view (TV) of a plane is denoted by their corresponding lower-case letters withoutdashes as a, b, c and d etc.
4. The side view (SV) of a plane are denoted by their corresponding lower-case letters withdouble dashes as a", b", c" and d" etc.
5. Projectors are always drawn as continuous thin lines.
6. Line with specific thickness for a particular type of line.

In Computer Aided Engineering Graphics for projection of plane following commands are used other than evoking software, opening file, saving file and giving print command. Using these minimum12 commands any type of projection of line problem can be solved they are as follows:

1. Select tool Command.
2. Point command.
3. Poly-Line command.
4. Two Point Line command.
5. Parallel line command.
6. Center Circle command
7. Bisector command.

8. Smart Dimension command.
9. Line Width command.
10. Insert Text command.
11. Move Copy command.
12. Rectangle command.

Plane parallel and perpendicular to reference planes (HP & VP)

If the given plane is parallel to an RP, it remains perpendicular to the other RP. In such a case, the view of the plane on the RP to which it is parallel gives the true shape. Another view is always an edge view parallel to XY.

Plane parallel to HP and perpendicular to VP.

If a plane is parallel to the HP, its TV gives the true shape. Therefore, TV should be drawn first. FV will be an edge view parallel to XY. SV will be perpendicular to XY.

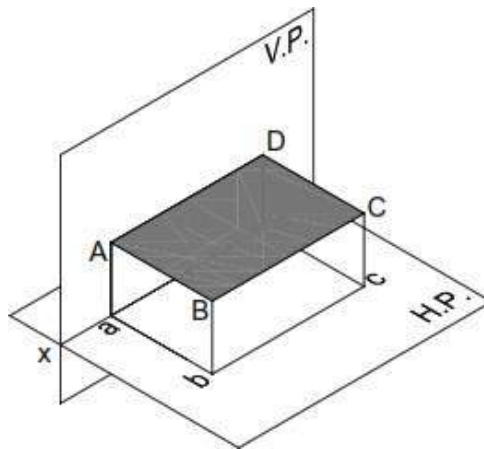

Plane parallel to HP and perpendicular to VP.

Plane parallel to VP and perpendicular to HP.

If a plane is parallel to the VP, its FV gives the true shape. Therefore, FV should be drawn first. TV will be an edge view parallel to XY. SV will be perpendicular to XY.

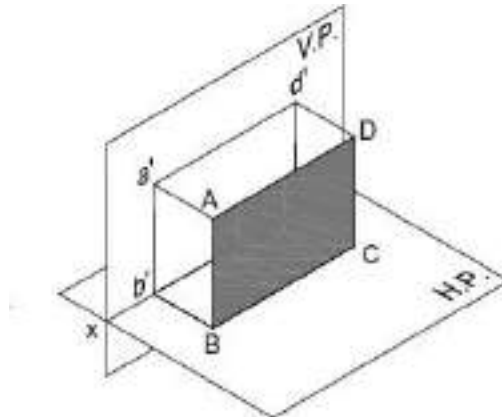

Plane parallel to VP and perpendicular to HP.

Plane Inclined to one RP and Perpendicular to the other RP

If a plane is inclined to one RP and perpendicular to the other RP, none of its views will give the true shape. The view on the RP to which the plane is inclined will be smaller than the actual size of the plane. The view on the RP to which the plane is perpendicular will be a line view. Such problems can be solved in two stages. In the first stage, the given plane is assumed to be parallel to the RP to which it is finally inclined. The true shape can thus be obtained in one view. In the second stage, another view (which is an edge view parallel to XY) is tilted so as to make desired inclination with the first RP.

Plane Inclined to the HP and Perpendicular to the VP

When the surface of the plane is inclined at θ to the H.P. and perpendicular to the V.P., the projections are obtained in two stages. In the first stage, the plane is assumed to lie on the H.P. The true shape of the plane is viewed in the top view and a straight line lying on xy in the front view. In the second stage, the plane is tilted at θ to the H.P. The front view is redrawn inclined at θ to the xy. The final top view is obtained by joining the points of intersection of the vertical projectors of the corners from the front view with the horizontal projectors of the corners from the top view of the preceding stage.

Note 1 If the plane has a side on the H.P. (or parallel to the H.P. or on the ground), then keep an edge of the plane perpendicular to xy in the top view of the first stage.

Note 2 If the plane has a corner in the H.P. (or on the ground), then keep the line joining a corner and the centre of the plane parallel to xy.

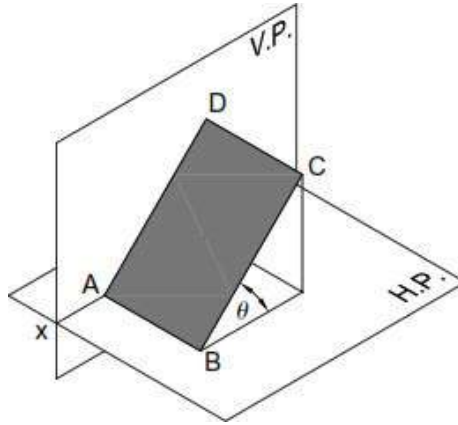

Plane Inclined to the HP and Perpendicular to the VP

Plane Inclined to the VP and Perpendicular to the HP

When the surface of the plane is inclined at ϕ to the V.P. and perpendicular to the H.P., the projections are obtained in two stages. In the first stage, the plane is assumed to lie on the V.P. The true shape of the plane is viewed in the front view and a straight line lying on xy in the top view. In the second stage, the plane is tilted at ϕ to the V.P. The top view is redrawn inclined at ϕ to the xy . The final front view is obtained by joining the points of intersection of the vertical projectors of the corners from the top view with the horizontal projectors of the corners from the front view of the preceding stage.

Note 1 If the plane has a side on the V.P. (or parallel to the V.P. or on the ground), then keep an edge of the plane perpendicular to xy in the front view of the first stage.

Note 2 If the plane has a corner in the V.P. (or on the ground), then keep the line joining a corner and the centre of the plane parallel to xy in the front view of the first stage.

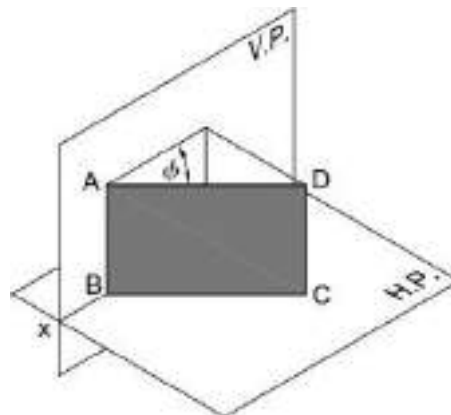

Plane Inclined to the VP and Perpendicular to the HP

Plane perpendicular to both HP & VP.

If a plane is perpendicular to both the RPs, then its FV and TV both will be seen as edge views perpendicular to XY. Such a plane is parallel to the PP and hence its true shape is seen in SV. Therefore, for such problems, it is advisable to draw SV first.

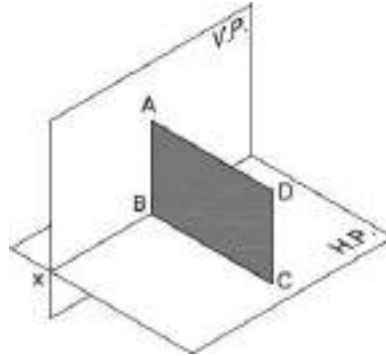

Plane Perpendicular to both HP & VP

Plane inclined to both HP & VP.

A plane inclined to both the RPs is called an *oblique plane*. None of the views of the oblique plane gives the true shape. It should be noted that the angles made by the oblique plane with the RPs (i.e., θ and ϕ) might not be directly given in the problem. Often, either of the inclinations, θ or ϕ , is given along with some other condition(s) that automatically pose the restriction on the other inclination.

The problems on oblique planes are solved in three stages. In the first stage, the plane is often assumed to be parallel to one of the RPs so that the true shape can be obtained in one view. In the second stage, the given angle between the plane and the RP (i.e., either the HP or the VP) or some other condition mentioned in the problem is established. In the third stage, all other remaining conditions are satisfied.

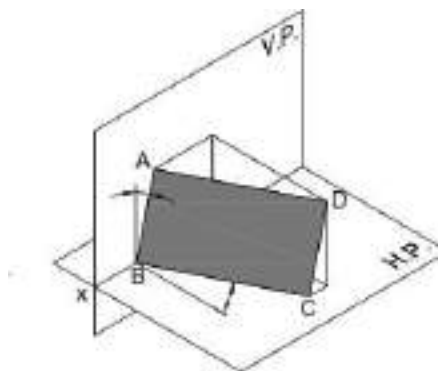

Plane Inclined to both HP & VP

Solved Problems

1. An equilateral triangular lamina of 25 mm side lies with one of its edges on HP such that the surface of the lamina is inclined to HP at 60° . The edge on which it rests is inclined to VP at 60° . Draw the projections.

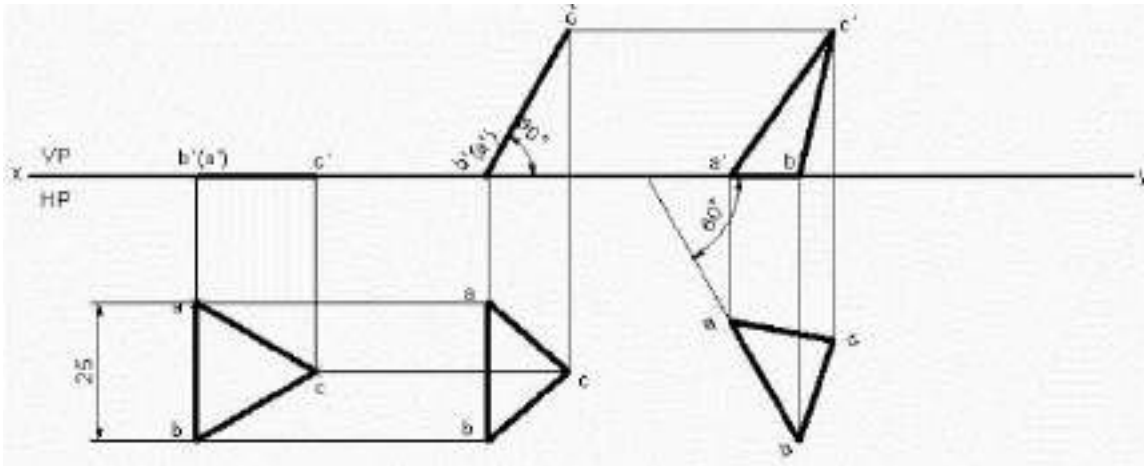

Solution

1. Open the Software. Click on the Application Menu and click on New and select “acad” in the open dialog box and click Open.
2. Enter the command “UNITS” in command bar and Select units as “Millimeters and click ok.
3. Enter the command “LIMITS” in command bar and enter 0,0 click enter and enter upper right corner as 120,90 and click enter
4. Enter the command “ZOOM” in command bar and enter A and click enter
5. Draw a XY line by using line command. Mark VP and HP above and below it by using “XTEXT” command in command bar
6. As per the problem equilateral triangular lamina of 25mm has to be drawn in HP, hence draw a vertical line of 25 mm using POLYLINE command and in format select VL and enter length as 25 and angle as -90 in mini dialog box. Mark annotations a and b using XTEXT Command as shown below.



7. Draw an arc of radius of 25 from a and b to cut each other at c using CENTER CIRCLE command in drafting tool bar and in format select PL. In mode option select arc. Join abc to get triangular lamina of 25 mm using POLYLINE command
8. Draw front view of the triangular lamina using POLYLINE command and in format select VL, mark annotations as (a') b' and c' as shown below.



9. Since the lamina is inclined at 60° to HP. By using POLYLINE command and in format select VL enter length equal to length of first stage front view and angle as 60 in mini dialog box, mark annotations as (a') b' and c' using XTEXT Command
10. Draw vertical projectors downwards from the second front view using POLYLINE command and in format select PL. Draw horizontal projectors from top view to intersect vertical projectors at a, b and c which forms the second stage top view as shown below.

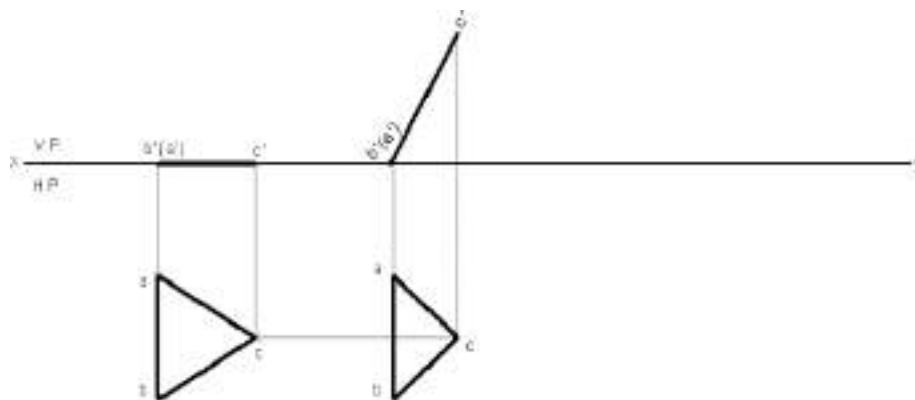

11. Since the edge on which it rests is inclined to VP to 60° Draw a line of 60° in HP using POLYLINE command and in format select PL. From edit menu select MOVE COPY command and then select second stage top view. In selection tree right click on the start point and click reset to select the start point anywhere on the edge of lamina to shift on to 60° line drawn. Click and drag the lamina on 60° line. Click or drag to rotate and enter angle as 30 in mini dialog box and click on OK
12. Draw the vertical projection upwards from all the corners of triangular lamina from third stage top view using POLYLINE command and in format select PL. Again, draw horizontal projectors from second stage front view to intersect vertical projectors at a' b' and c' .

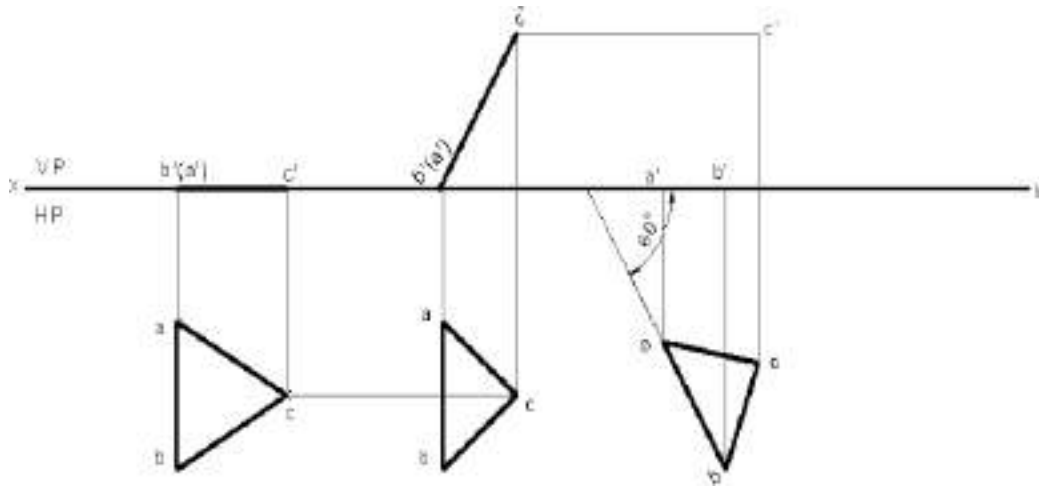

13. Join a' b' and c' using POLYLINE Command
14. Using DIMENSION Command in Annotation tool bar or Enter DIM command in command bar dimension the drawing

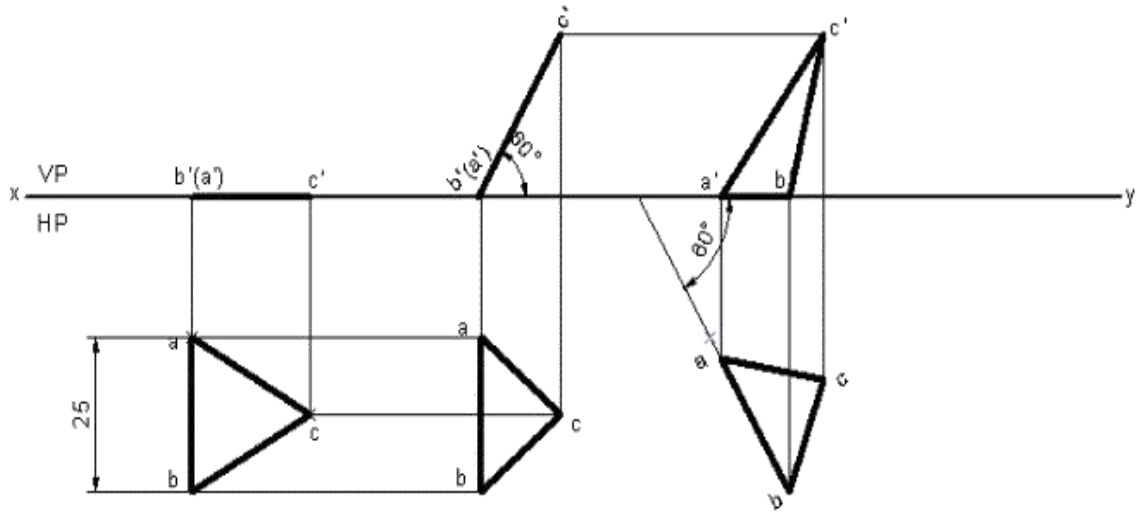

2. A square plate of 40 mm side rests on HP such that one of the diagonals is inclined at 30° to HP and 45° to VP. Draw its projections.

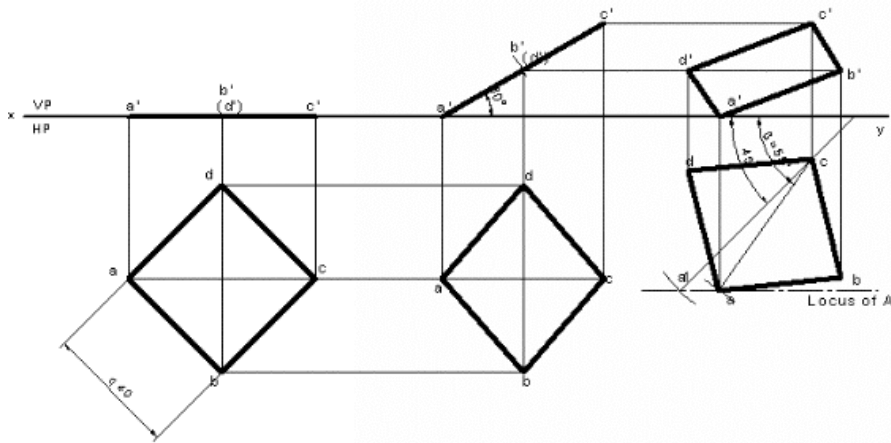

Solution

1. Open the Software. Click on the Application Menu and click on New and select “acad “in the open dialog box and click Open.
2. Enter the command “UNITS “in command bar and Select units as “Millimeters and click ok.
3. Enter the command “LIMITS “in command bar and enter 0,0 click enter and enter upper rightcorner as 100,100 and click enter
4. Enter the command “ZOOM “in command bar and enter A and click enter

5. Draw a XY line by using line command. Mark VP and HP above and below it by using "XTEXT" command in command bar.
6. As per the problem a square lamina of 40 mm has to be drawn in HP, hence draw a square of 40 mm using RECTANGLE command Now enter X size = 40, Y size = 40 and angle as 45 in mini dialog box. Mark annotations a b c and d using XTEXT Command as shown below.

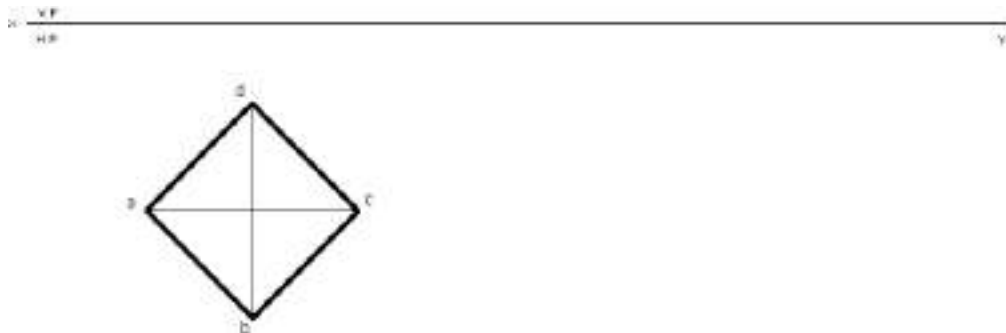

7. Draw the vertical projection upwards from all the corners of square lamina in top view until it touches XY line, using POLYLINE command and in format select PL.
8. Draw front view of the triangular lamina using POLYLINE command and in format select VL, mark annotations as a' b' c' and (d') as shown below.

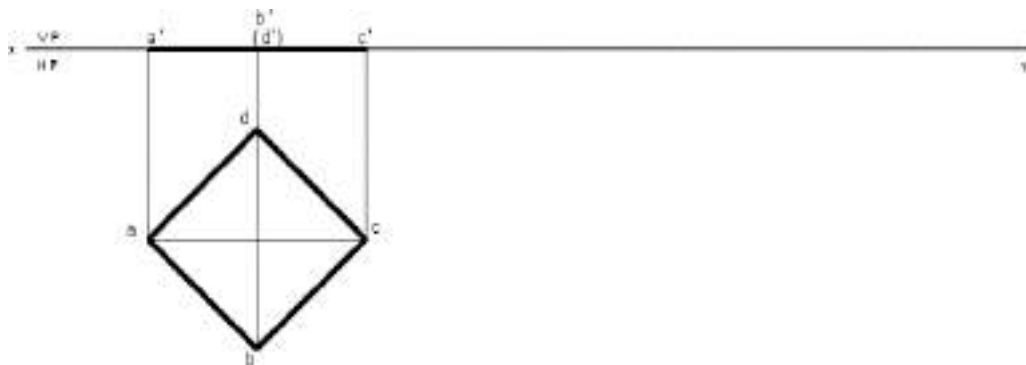

9. Since the diagonal of lamina is inclined at 30° to HP. By using POLYLINE command and in format select VL enter length equal to length of first stage front view and angle as 30 in mini dialog box, mark annotations as a' b' (d') and c' using XTEXT command
10. Draw vertical projectors downwards from the second front view using POLYLINE command and in format select PL. Draw horizontal projectors from top view to intersect vertical projectors at a, b c and d which forms the second stage top view as shown below.

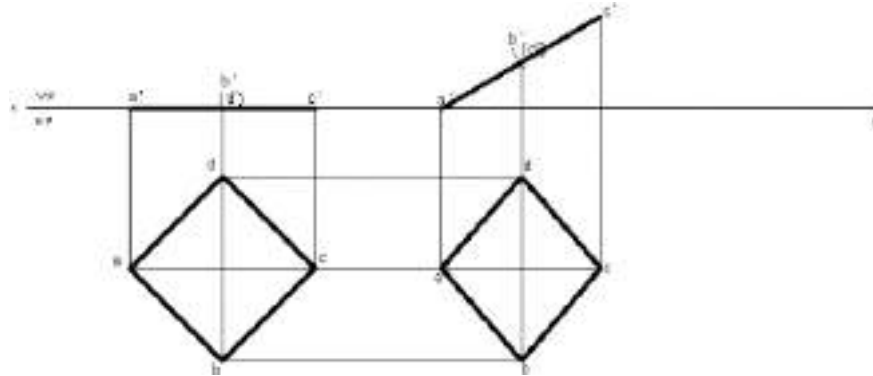

11. Since the diagonal of lamina is inclined to VP at 45° . Draw a line of 45° in HP using POLYLINE command and in format select PL. Draw an arc of radius equal to diagonal length of lamina from first stage top view to cut on 45° line drawn. Draw a locus from point a1, now with radius equal to diagonal length of lamina from second stage top view to cut on the locus. Join ac to get the diagonal of third stage top view. From edit menu select MOVE command and then select second stage top view. In selection tree right click on the start point and click reset to select the start point anywhere on the diagonal of lamina to shift on to new diagonal line drawn. Click and drag the lamina on new diagonal line. Click or drag to rotate and enter angle so as to match both diagonals and click on OK. Mark annotations as a b c and d.
12. Draw the vertical projection upwards from all the corners of square lamina from third stage top view using POLYLINE command and in format select PL. Again, draw horizontal projectors from second stage front view to intersect vertical projectors at a' b' c' and d'.
13. Join a' b' c' and d' using LINE Command and in format select VL.

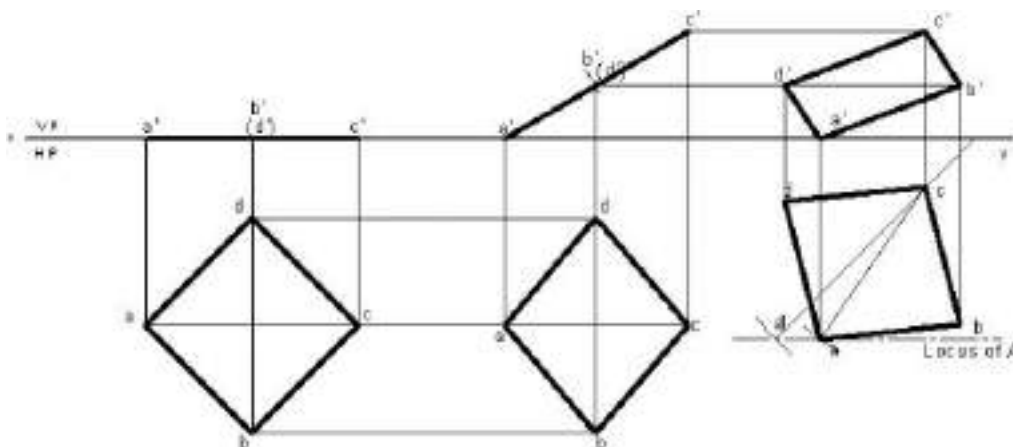

14. Using DIMENSION Command in Annotation tool bar or Enter DIM command in command bar dimension the drawing

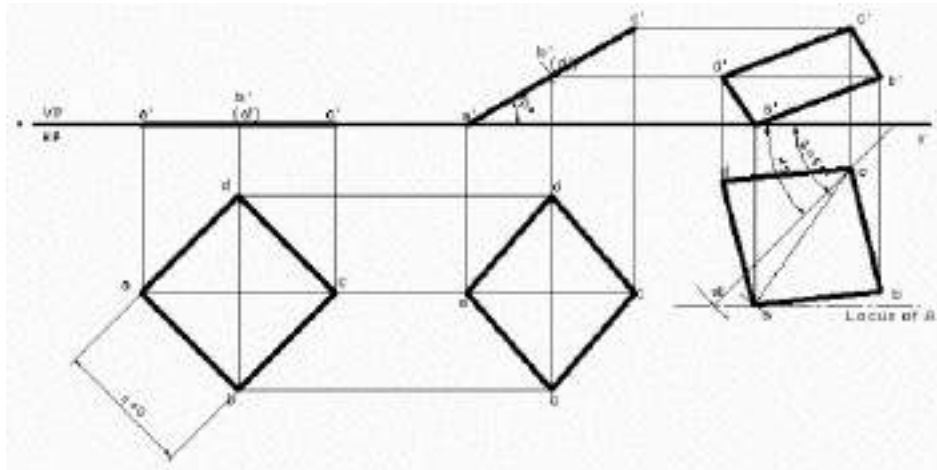

Practice Problems

- A Square plane with a 40 mm side has its surface parallel to and 20mm above the HP.
Draw its Projections, when
 - A side is parallel to VP
 - A side is inclined at 30° to VP and
 - All sides are equally inclined to VP.
- A Hexagonal plane with a 30mm side has its surface parallel to and 20mm in front of the VP.
Draw its Projections, when
 - A side is perpendicular to HP
 - A side is parallel to the HP
 - Side is inclined at 45° to the HP
- A Pentagonal plane with a 30 mm side has an edge on the HP, the surface of the Plane is inclined at 45° to the HP. Draw its Projections?
- A Hexagonal plate with a 30mm side and negligible thickness has its surface Perpendicular to the HP and inclined at 45° to the VP. Draw its Projections? When one of its sides of the Plane is Parallel to and 15 mm In front of the VP

5. A Circular plane with a 60 mm Diameter is resting on a point it's circumference on the VP. The center is 40mm above the HP, and the surface is inclined at 45° to the VP. and perpendicular to the HP Draw Its Projections?
6. Rectangle 30mm and 50mm sides is resting on HP on one of its small side which is 30° inclined to VP, while the surface of the plane makes 45° inclination with HP. Draw it's projections?
7. A regular pentagon of 30 mm sides is resting on HP, on one of its sides with its surface 45° inclined to HP. Draw it's projections when the side in HP makes 30° angle with VP?
8. A circle of 50mm diameter is resting on HP on end A of its diameter AC which is 30° inclined to HP while it's TV is 45° inclined to VP. Draw its Projections?
9. A semicircle of 100mm diameter is suspended from a point on its straight edge 30mm from the midpoint of that edge so that the surface makes an angle of 45° with VP. Draw its projections.
10. A pentagon of sides 30mm rests on the ground on one of its corners with the sides containing the corners being equally inclined to the ground. The side opposite to the corner on which it rests is inclined at 30° to the VP and is parallel to the HP. The surface of the pentagon makes 10° degrees with the ground. Draw the top and front views of the pentagon.
11. A regular pentagon of 30mm side is resting on one of its edges on HP which is inclined at 45° degrees to VP. Its surface is inclined at 30° degrees to HP. Draw its projections.
12. Draw the projections of a regular hexagon of 25mm side, having one of its sides in the H.P. and inclined at 60° degrees to the V.P and its surface making an angle of 45° degrees with H.P.
13. A thin circular plate of 40mm diameter having its plane vertical and inclined at 40° to V.P. Its center is 30mm above H.P. and 35mm in front of V.P. Draw the projections.

Projections of Solids

Introduction

Any object having definite length, width and height is called a solid. In engineering drawing, solids are often represented by two or more orthographic views, i.e., FV, TV or SV. The study of the projections of a solid is very important in mechanical-design problems. The knowledge of projections of solids is essential in 3D modeling and animation. Projections of solids find wide applications in the construction industry.

Basic Solids

Basic solids are those which have predefined shapes. The basic solids are the constituent parts of any complex solid. Objects in the real world are made up of combinations of basic solids. In 3D modeling, the basic solids are called solid primitives. Solid primitives are combined in logical ways to obtain the desired 3D shape.

System of Notation

7. The actual plane in space is denoted by capital letters A, B, C and D etc.
8. The front view (FV) of a plane is denoted by their corresponding lower-case letters with dashes as a' , b' , c' and d' etc.
9. The top view (TV) of a plane is denoted by their corresponding lower-case letters without dashes as a , b , c and d etc.
10. The side view (SV) of a plane are denoted by their corresponding lower-case letters with double dashes as a'' , b'' , c'' and d'' etc.
11. Projectors are always drawn as continuous thin lines.
12. Line with specific thickness for a particular type of line.

In Computer Aided Engineering Graphics for projection of solids following commands are used other than evoking software, opening file, saving file and giving print command. Using these minimum 13 commands any type of projection of line problem can be solved they are as follows:

Department of Mechanical Engineering

1. Select tool Command.
2. Point command.
3. Poly-Line command.
4. Two Point Line command.
5. Parallel line command.
6. Center Circle command
7. Bisector command.
8. Smart Dimension command.
9. Line Width command.
10. Insert Text command.
11. Move Copy command.
12. Rectangle command.
13. Smart Delete Command

Classification of solids

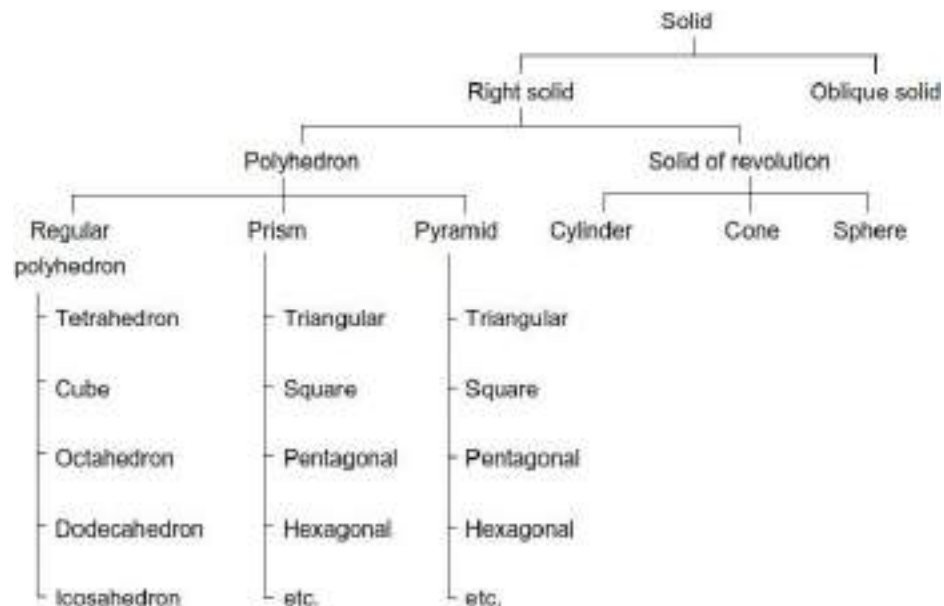
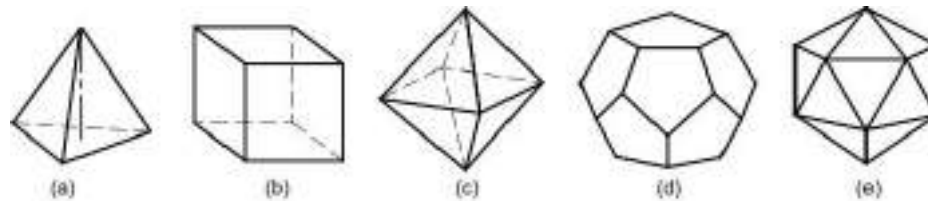

Figure 3.1 Classification of Regular Solids

Polyhedron

A polyhedron is a solid bounded by planes called faces, which meet in straight lines called edges. A regular polyhedron has all the faces equal and regular as shown in Fig. 3.2.

Department of Mechanical Engineering



(a) Tetrahedron (b) Cube (c) Octahedron (d) Dodecahedron (e) Icosahedron

Figure 3.2 Regular Polyhedron

Prism

A prism is a polyhedron with two n-sided polygonal bases which are parallel and congruent, and lateral faces are rectangles. All cross-sections parallel to the bases are congruent with the bases. An imaginary line that joins the centre of the bases is called an axis. A right and regular prism has regular polygonal bases, axis perpendicular to the bases and all the faces are equal rectangles, as shown in Fig.3.3. Prisms are named according to the shape of their base, so a prism with a triangular base is called a triangular prism; a square base is called a square prism and so on.

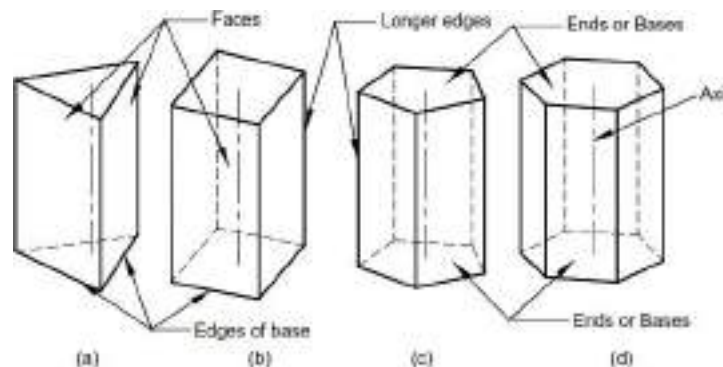

: (a) Triangular (b) Square (c) Pentagonal (d) Hexagonal

Figure 3.3 Prisms

Pyramid

A pyramid is a polyhedron with n-sided polygonal base and lateral faces are triangles meeting at a point called the vertex or apex. An imaginary line that joins the apex with the centre of the base is known as the axis. A right and regular pyramid has a regular polygon base, axis perpendicular to the base and all the faces are equal isosceles triangles, as shown in Fig. 3.4. Pyramids are named according to the shape of their base, so a pyramid with a triangular base is called a triangular pyramid; a square base is called a square pyramid and so on. The centre of gravity of pyramids lies on the axis at one-fourth of its height from the base.

Department of Mechanical Engineering

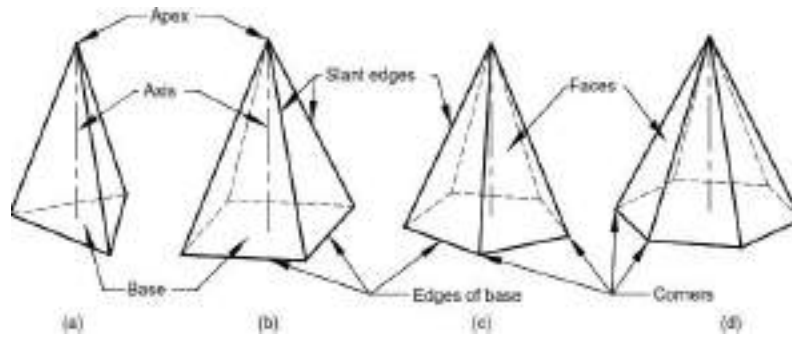

: (a) Triangular (b) Square (c) Pentagonal (d) Hexagonal

Figure 3.4 Pyramids

Solid of Revolution

These solids are obtained by revolving a plane figure like rectangle, triangle or a semi-circle about a fixed line.

Cylinder: A cylinder is a solid of revolution obtained by revolving a rectangle about one of its fixed side called an axis. It can be imagined as a prism of infinite number of lateral faces. Any line on the surface of a cylinder is called its generator. Thus, a cylinder has an infinite number of generators. A right cylinder has all the generators and the axis perpendicular to the base, as shown in Fig. 3.5(a).

Cone: A cone is obtained by revolving a triangle about its fixed side called an axis. A cone can be imagined as a pyramid with infinite number of lateral faces. Any line on the surface of a cone is called its generator. Thus, a cone has an infinite number of generators. A right cone has all generators of equal length and the axis perpendicular to the base, as shown in Fig. 3.5(b).

Sphere: A sphere is obtained by revolving a semi-circle around its diameter, as shown in Fig

Oblique Solid

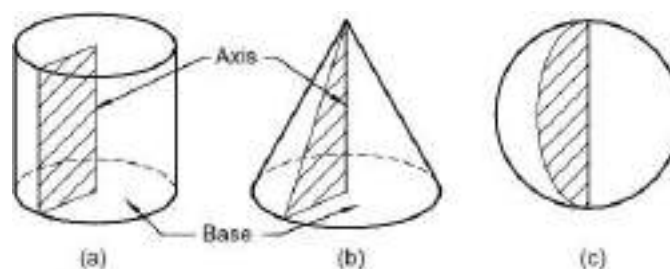
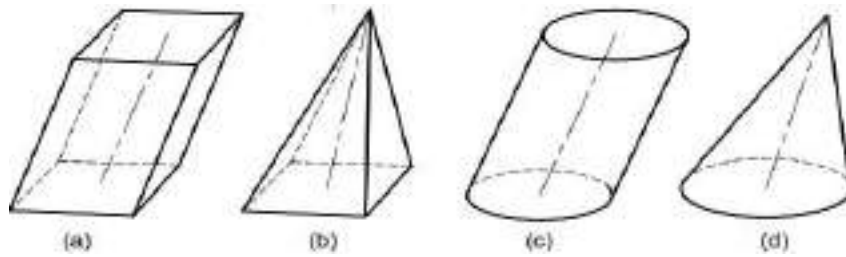

Figure 3.5 Solids of Revolution

An oblique solid such as oblique prism, pyramid, cylinder or cone has its axis inclined to its base as shown in Fig.3.6. The faces of an oblique prism are parallelograms of different sizes. The faces of an oblique pyramid are triangles of different sizes. The generators in an oblique cylinder have equal lengths whereas those in an oblique cone have unequal lengths.

Department of Mechanical Engineering



(a) Square prism (b) Square pyramid (c) Cylinder (d) Cone

Figure 3.6 Oblique Solids

Frustum of Pyramid and Cone

When a regular pyramid or a cone is cut by a plane parallel to its base and the portion of the solid containing apex is removed, the remaining portion of the solid is called the frustum of that pyramid or cone, as shown in Fig. 3.7.



(a) Square pyramid (b) Hexagonal pyramid (c) Cone

Figure 3.7 Frustums

Recommended Method of Labelling

It is recommended to label the corners of the solids in a manner as shown in Fig. 3.8.

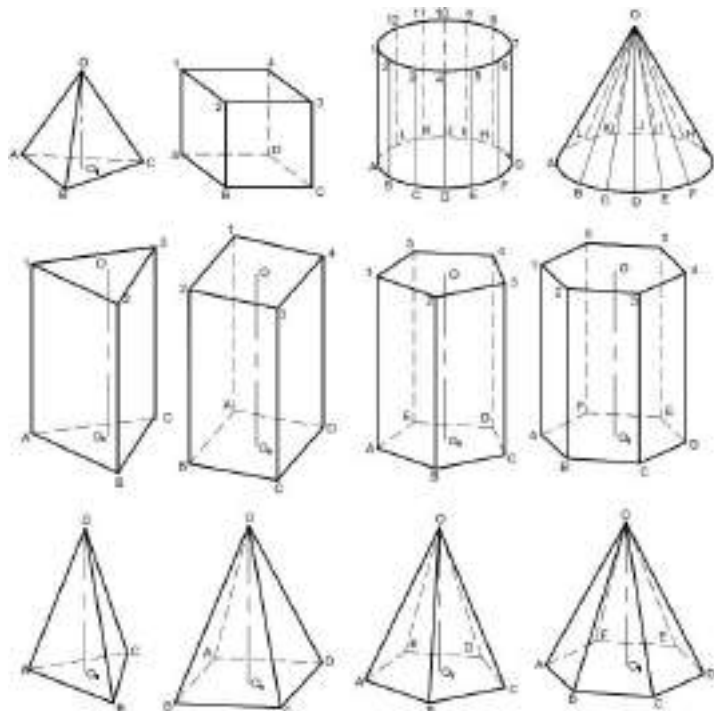

Department of Mechanical Engineering

Figure 3.8 Method of Labelling

Positions of Solids

The position of a solid in space is specified by the inclinations of its axis with the RPs. Therefore, a solid will have positions with respect to RPs same as that of a line. Depending on the orientation of its axis in space, a solid may have the following positions:

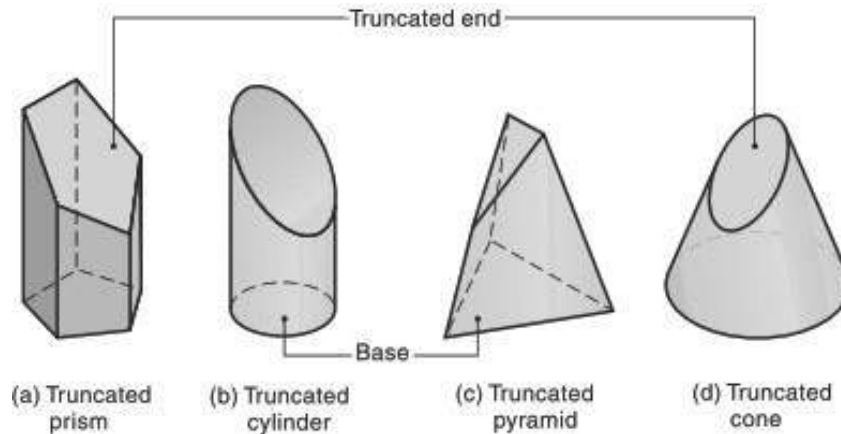

Figure 3.9 Truncated Solids

The solid may be in one of the following positions:

1. Axis perpendicular to the H.P.
2. Axis perpendicular to the V.P.
3. Axis parallel to both the H.P. and the V.P. (i.e., perpendicular to the profile plane)
4. Axis inclined to the H.P. and parallel to the V.P.
5. Axis inclined to the V.P. and parallel to the H.P.
6. Axis inclined to both the H.P. and the V.P.

Axis Perpendicular to H.P.

This is one of the basic positions of the solid. It is evident that if the axis of a right solid is perpendicular to the H.P., its base will be parallel to the H.P. The true shape and size of the base can be viewed in the top view. Therefore, first obtain the top view of the solid and then project it to obtain the front view.

Department of Mechanical Engineering

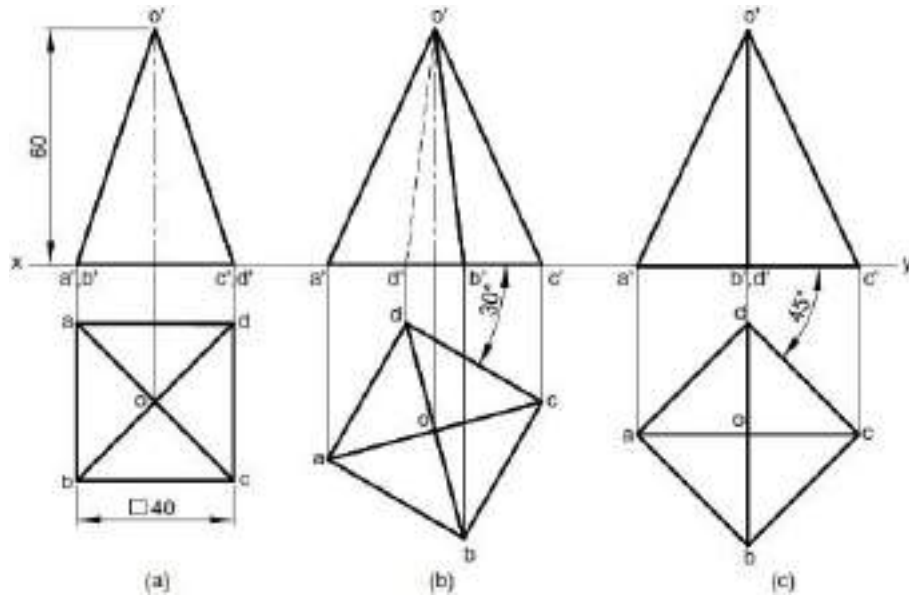

Figure 3.10 Axis Perpendicular to H.P.

Axis Perpendicular to V.P.

This is one of the basic positions of the solid. It is evident that if the axis of a right solid is perpendicular to the V.P., its base will be parallel to the V.P. The true shape and size of the base can be viewed in the front view. Therefore, first obtain the front view of the solid and then project it to obtain the top view.

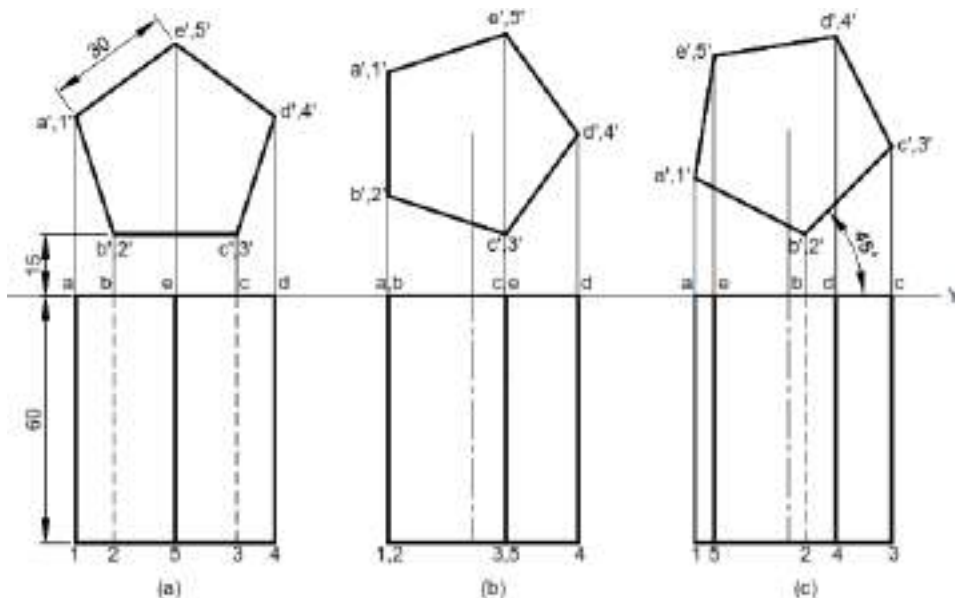

Figure 3.11 Axis Perpendicular to V.P.

Axis Parallel to both H.P. and V.P.

It is evident that if the axis of right solids is parallel to both H.P. and V.P., the base of the solid will be perpendicular to the reference planes and parallel to the profile plane. The true shape

Department of Mechanical Engineering

and size of the base can be viewed in the side view. Therefore, first obtain the side view of the solid and then project it to obtain the front and the top views.

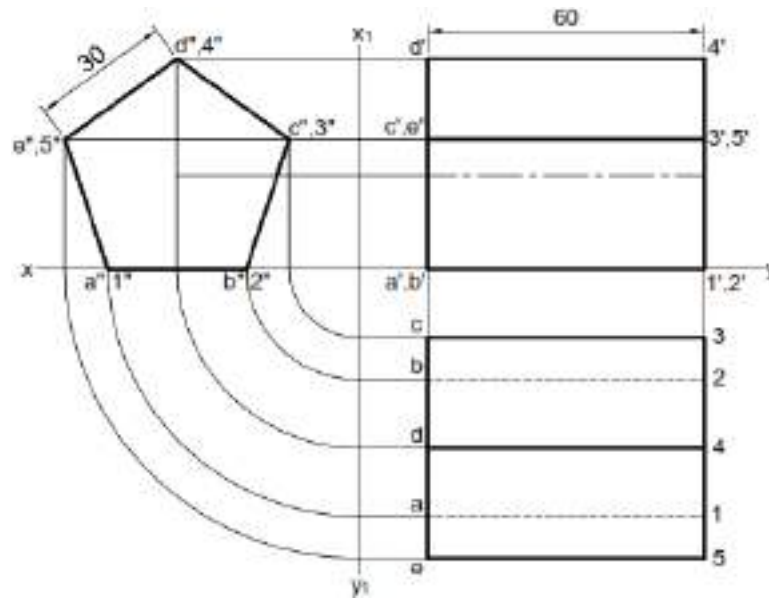

Figure 3.12 Axis Parallel to both H.P and V.P.

Axis inclined to the R.P. and parallel to the R.P.

If the axis of a solid is inclined to one RP and parallel to the other RP then the problem is solved in two stages. In the first stage, the axis is assumed to be perpendicular to the RP to which it is finally inclined. The view obtained on that RP will give the true shape of the base. The corresponding other view will give the TL of the axis. In the second stage, the other view is redrawn in such a way that the axis will make the required angle with the given RP.

Here, it should be noted that the inclination of the axis with a particular RP might not be given directly. Instead, it may be expressed in terms of other parameters, as mentioned earlier.

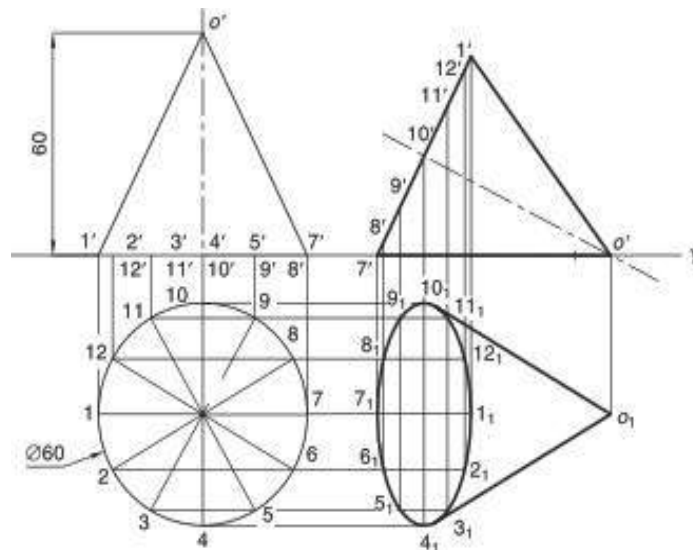

Figure 3.13 Axis inclined to the H.P. and parallel to the V.P.

Department of Mechanical Engineering

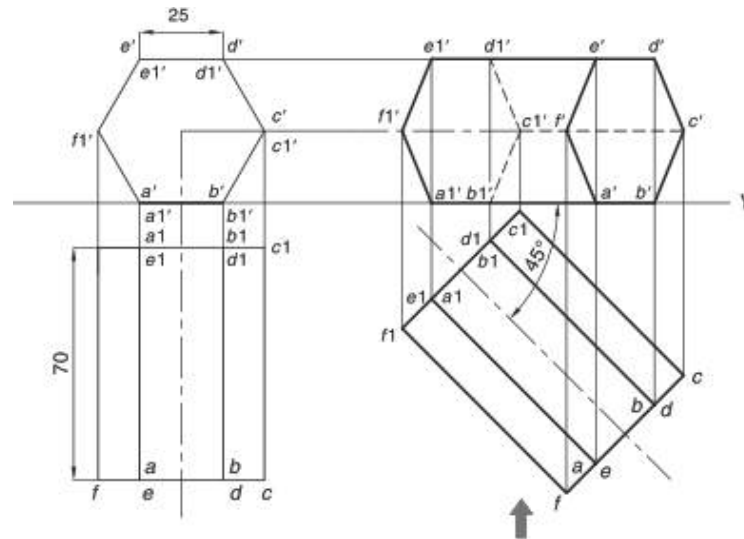

Figure 3.14 Axis inclined to the V.P. and parallel to the H.P.

Axis inclined to the both R.P ‘S.

If the axis of a solid is inclined to both the RPs then the problem is solved in three stages. As already mentioned, the inclinations of the axes may not be given directly. Instead, it may be indirectly mentioned by means some other parameters. If the inclinations are given directly then, in the first stage, the axis is assumed to be perpendicular to any one RP. The view obtained on that RP will give the true shape of the base. The corresponding other view will give the TL of the axis. In the second stage, the other view is redrawn so that the axis will make the required angle with the RP to which it was initially perpendicular. The corresponding next view is obtained in the second stage. In the third stage, the next view is redrawn so as to make the ‘desired inclination’ of the axis with the other RP. Here, the ‘desired inclination’ is the apparent inclination of the axis which is obtained by using the theory of projections of the lines. The view thus obtained satisfies all the conditions, i.e., inclinations with both the RPs, and hence represents the final view. This view is then projected to obtain the other corresponding final view.

If the inclinations are not given directly then the first stage must be decided carefully. Often an inclination of the axis with one RP is given and the inclination with the other RP is given in terms of the inclination of an edge or face of the solid. In such a case, the first stage is to keep the axis perpendicular to that RP with which its inclination is known. In the second stage, the required inclination with that RP is obtained. In the third stage, the other condition, viz., inclination of the face or inclination of an edge, is established. It must be remembered that, in the first stage, the solid is always kept in such a way that the true shape of the base and TL of the axis are visible. This helps to satisfy the condition on the axis (mentioned directly or

Department of Mechanical Engineering

indirectly) easily in the second stage. Note that one view in the second stage always gives TL of the axis (since it is simply redrawn from the first stage).

Other possibilities are explained with the help of examples.

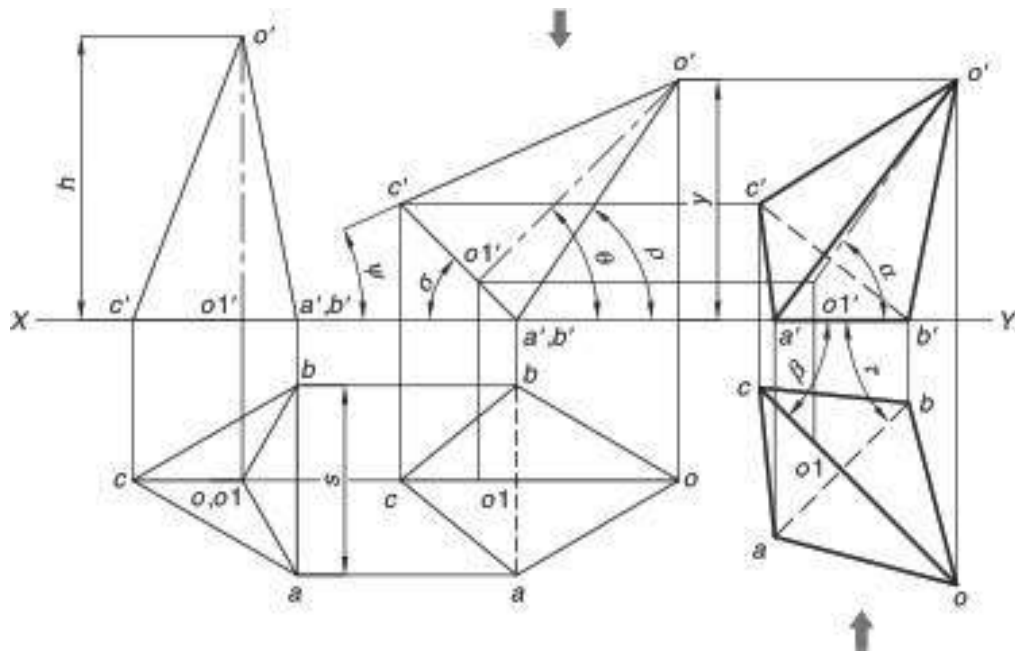
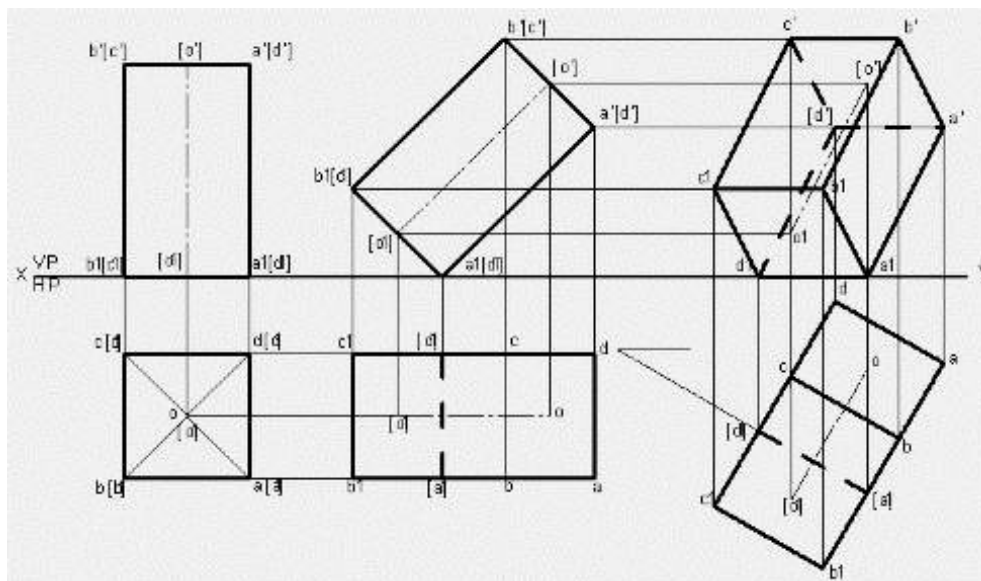

Figure 3.15 Axis inclined to the both R.P.

Solved Problems

1. A square prism 35 mm side of base and 60 mm axis length rests on HP on one of its edges of the base which is inclined to VP at 30°. Draw the projections of the prism when the axis is inclined to HP at 45°.



Department of Mechanical Engineering

Solution

1. Open the Software. Click on the Application Menu and click on New and select “acad” in the open dialog box and click Open.
2. Enter the command “UNITS” in command bar and Select units as “Millimeters and click ok.
3. Enter the command “LIMITS” in command bar and enter 0,0 click enter and enter upperright corner as 100,100 and click enter
4. Enter the command “ZOOM” in command bar and enter A and click enter
5. Draw a XY line by using line command. Mark VP and HP above and below it by using “XTEXT” command in command bar
6. As per the problem draw a square lamina of 35 mm in HP using RECTANGLE command and in format select first corner and click enter and select Area, Now enter X size = 35, Y size = 35 and similarly label the bottom face as a1 b1 c1 d1 center as o1 using XTEXT Command
7. Draw the horizontal line at a distance of 60 mm i.e., equal to height of the square prism above the XY line using LINE COMMAND and enter 60 in mini dialog box. Draw the vertical projection upwards from top view, until they intersect horizontal line at 60 mm above XY line using POLYLINE command. Mark the intersection points as a' b' c' d' and o' for the top face and a1' b1' c1' d1' and o1' for bottom of the square prism.
8. Since the square prism axis is inclined at 45° to HP. By using POLYLINE command and in format select PL enter length equal to length (60) of first stage front view and angle as 45 in mini dialog box draw a line of 45°. Mark the annotations as shown below.

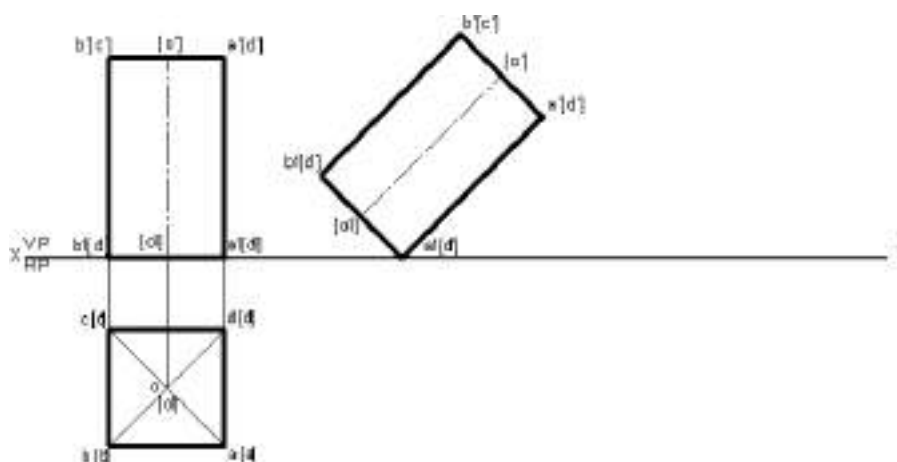

9. Draw vertical projectors downwards from the second stage front view using POLYLINE command and in format select PL. Draw horizontal projectors from top view to intersect vertical projectors to get required second stage top view by joining intersection points by

Department of Mechanical Engineering

using LINE Command and in format select VL as shown below. Note the invisible (hidden) lines are to be dotted. Hence draw invisible line using POLYLINE command and in format select DL.

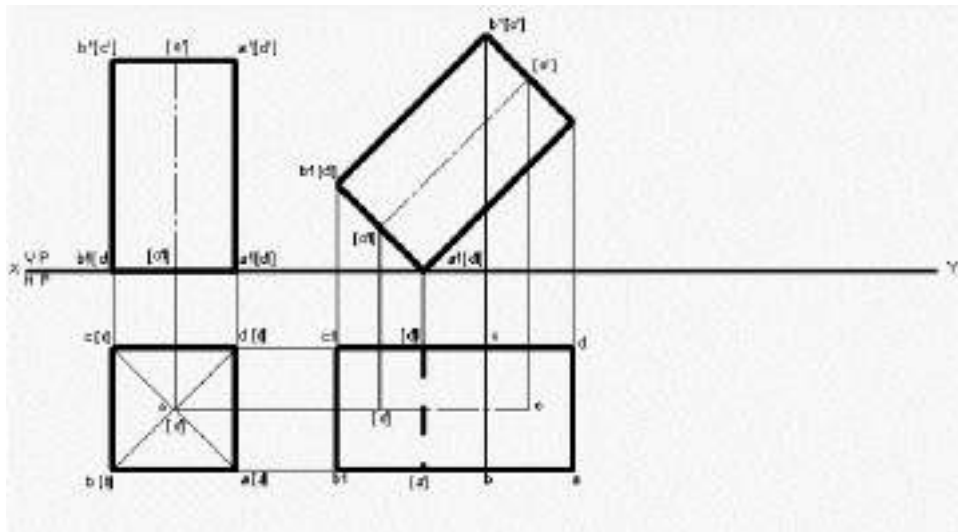

10. Since the edge on which prism rests is inclined to VP at 30°. Draw a line of 30° in HP using POLYLINE command and in format select PL. Mark annotations as shown below.

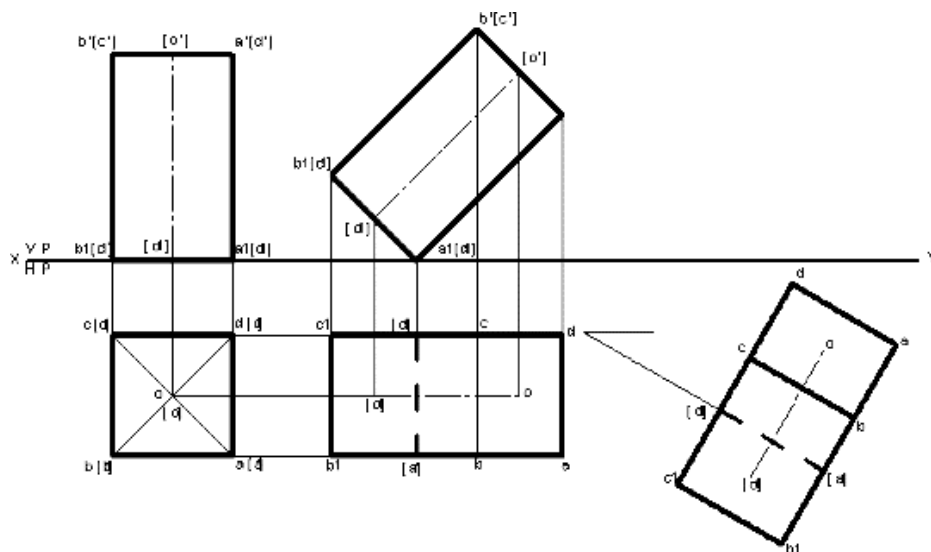

11. Draw the vertical projection upwards from the third stage top view using POLYLINE command and in format select PL. Again, draw horizontal projectors from second stage front view to intersect vertical projectors to get the final front view. Join all the intersection points using LINE Command and in format select VL.
12. Using DIMENSION Command in Annotation tool bar or Enter DIM command in command bar dimension the drawing

Department of Mechanical Engineering

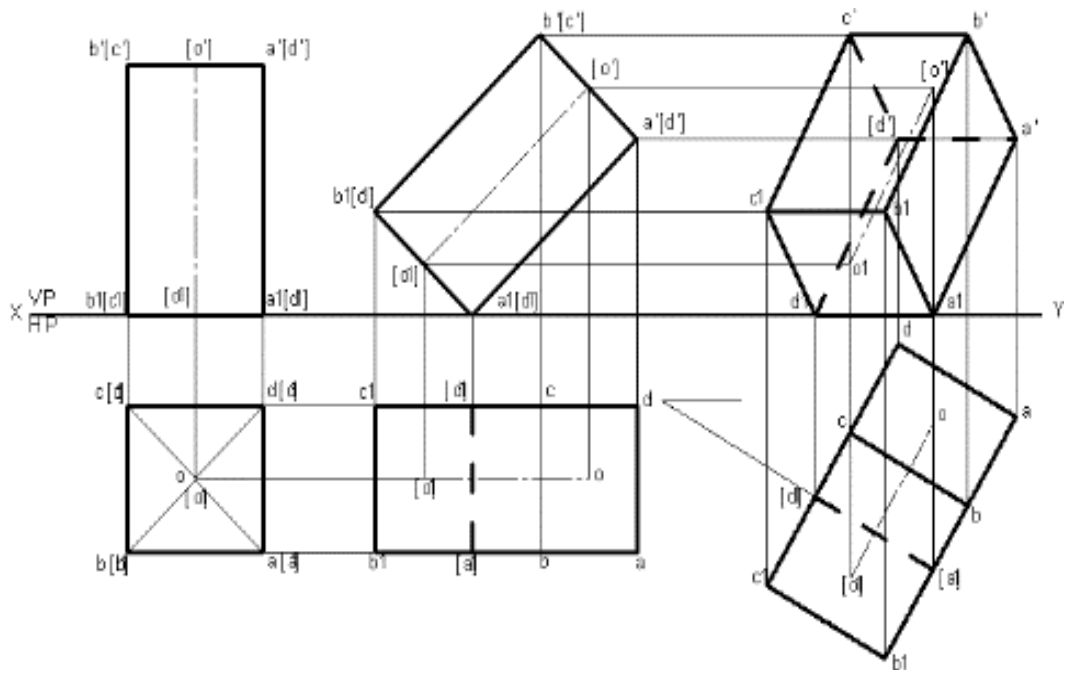

2. A hexagonal prism 25 mm sides of base and 50 mm axis length rests on HP on one of its corners of the base such that the two base edges containing the corner on which it rests make equal inclinations with HP. Draw the projections of the prism when the axis of the prism is inclined to HP at 40° and to VP at 30° .

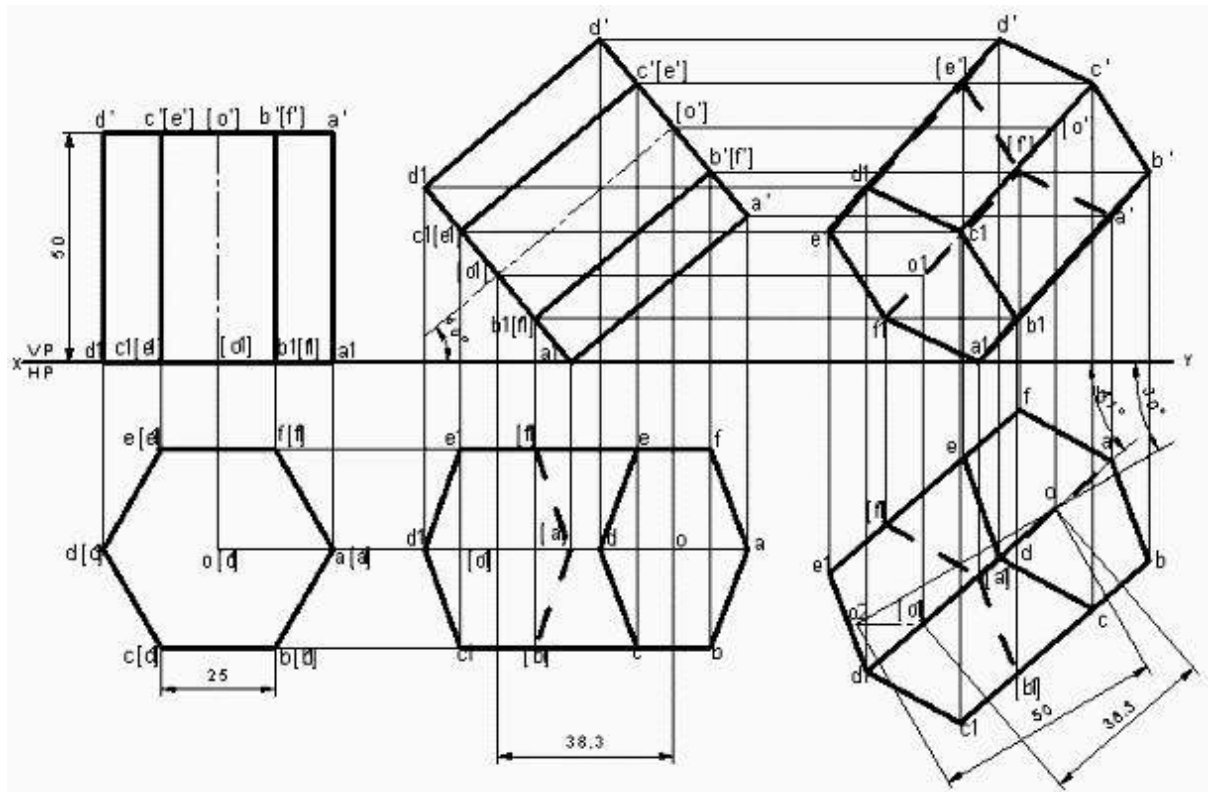

Department of Mechanical Engineering

Solution

1. Open the Software. Click on the Application Menu and click on New and select “acad” in the open dialog box and click Open.
2. Enter the command “UNITS” in command bar and Select units as “Millimeters and click ok.
3. Enter the command “LIMITS” in command bar and enter 0,0 click enter and enter upperright corner as 100,100 and click enter
4. Enter the command “ZOOM” in command bar and enter A and click enter
5. Draw a XY line by using line command. Mark VP and HP above and below it by using “XTEXT” command in command bar
6. As per the problem draw a hexagonal lamina of 25 mm in HP using POLYLINE command and in format select VL and enter edges as 6, radius as 25. Mark the corner points of top face as a b c d e f and center as o. Similarly label the bottom face as a1 b1 c1 d1 e1 f1 center as o1 using XTEXT Command
7. Draw the horizontal line at a distance of 50 mm i.e., equal to height of the hexagonal prism above the XY line using PARALLEL LINE COMMAND and enter 50 in mini dialog box. Draw the vertical projection upwards from top view, until they intersect horizontal line at 50 mm above XY line using POLYLINE command. Mark the intersection points as a' b' c' d' e' f' and o' for the top face and a1' b1' c1' d1' e1' f1' and o1' for bottom of the square prism.

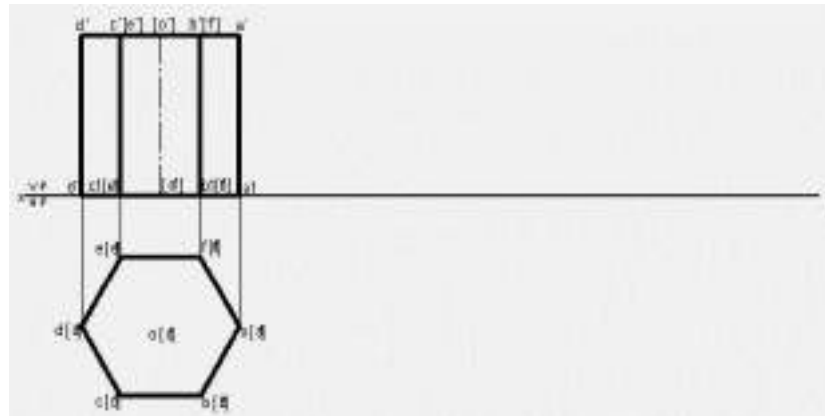

8. Since the hexagonal prism axis is inclined at 40° to HP. By using POLYLINE command and in format select PL enter length equal to length (50) of first stage front view and angles 40 in mini dialog box to draw a line of 40° . Mark the annotations as shown below.
9. Draw vertical projectors downwards from the second stage front view using POLYLINE command and in format select PL. Draw horizontal projectors from top view to intersect vertical projectors to get required second stage top view by joining intersection points by using LINE Command and in format select VL as shown below. Note the invisible (hidden)

Department of Mechanical Engineering

lines are to be dotted. Hence draw invisible line using POLYLINE command and in format select DL.

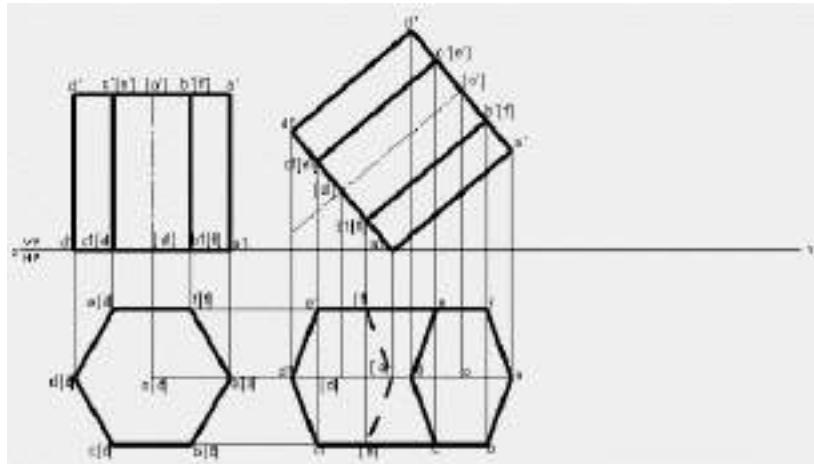

10. As per the problem draw a line of 30° in HP using POLYLINE command and in format select PL. Draw an arc of radius equal to axis of prism from first stage front view to cut on 30° line drawn. Draw a locus from point o_1 , now with radius equal to axis of prism from second stage top view to cut on the locus. Join o o_1 to get the axis of third stage top view.
11. Draw the vertical projection upwards from the third stage top view using POLYLINE command and in format select PL. Again, draw horizontal projectors from second stage front view to intersect vertical projectors to get the final front view. Join all the intersection points using LINE Command and in format select VL and draw invisible line using POLYLINE command and in format select DL.

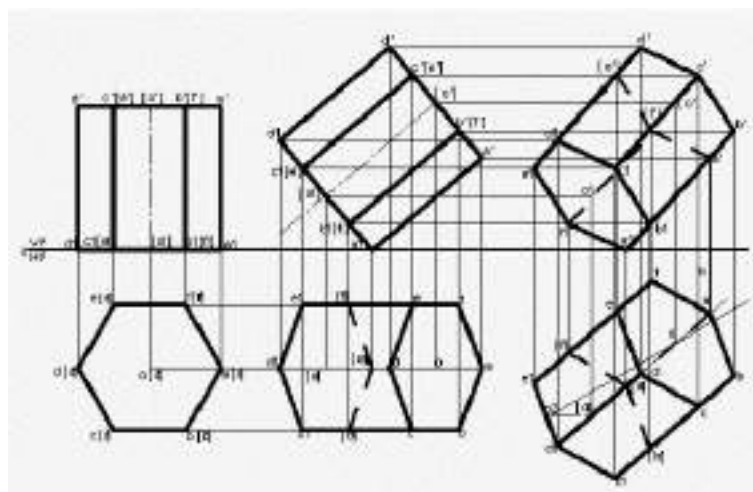

12. Using DIMENSION Command in Annotation tool bar or Enter DIM command in command bar dimension the drawing

Department of Mechanical Engineering

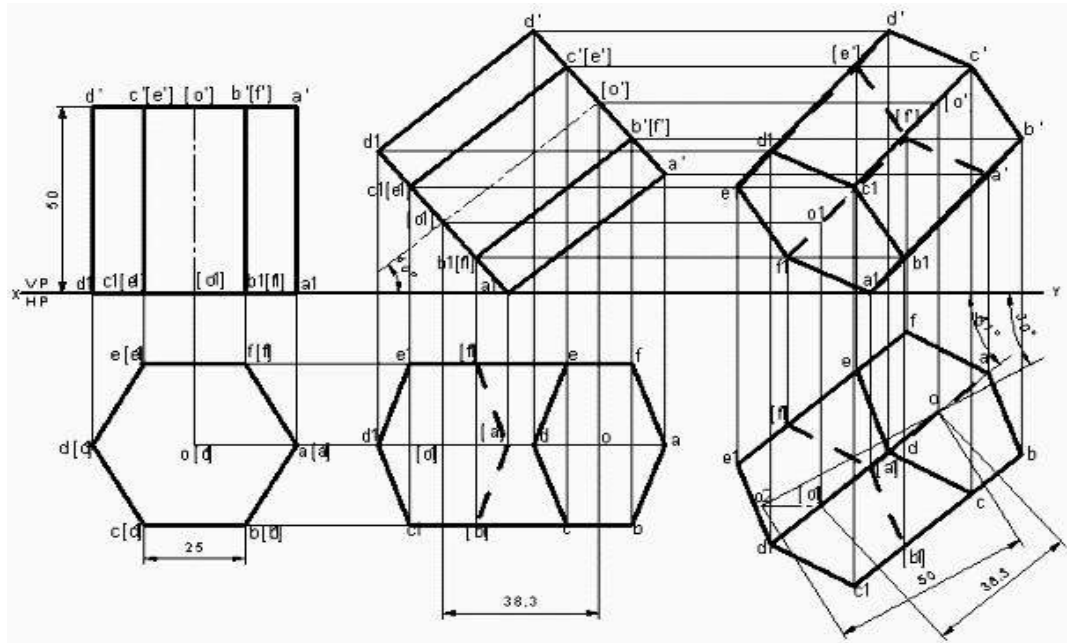

Practice Problems

1. A Square Pyramid, having base with a 40mm side and 60mm axis is resting on its base on the HP. Draw its Projections when
 - (a) A side of the base is parallel to the VP.
 - (b) A side of the base is inclined at 30° to the VP and
 - (c) All the sides of base are equally inclined to the VP
2. A pentagonal Prism having a base with 30 mm side and 60 mm long Axis, has one of Its bases in the VP. Draw Its projections When
 - (a) Rectangular face is parallel to and 15 mm above the HP
 - (b) A rectangular face perpendicular to HP and
 - (c) A rectangular face is inclined at 45° to the HP
3. A pentagonal Prism having a base with a 30 mm side and 60 mm long axis, is resting on one of its rectangular faces on the HP. with axis parallel to the VP. Draw its projections?
4. A hexagonal Prism having a base with a 30 mm side and 75 mm long axis, has an edge its base on the HP, its axis parallel to the VP and inclined at 45° to the HP. Draw its projections?
5. A hexagonal Prism having a base with a 30 mm side and 65 mm long axis, has an edge its base on the VP, its axis parallel to the HP and inclined at 30° to the VP. Draw its projections?
6. A cube of 50 mm long edges is so placed on HP on one corner that a body diagonal is Parallel to HP and perpendicular to VP. Draw its projections.

Department of Mechanical Engineering

7. A cone 40 mm diameter and 50 mm axis are resting on one of its generators on HP which makes 30° inclinations with VP. Draw its projections.
8. A circular cone, 40 mm base diameter and 60 mm long axis is resting on HP, on one point of base circle such that its axis makes 45° inclination with HP and 40° inclination with VP. Draw its projections.
9. A cylinder 40 mm base diameter and 50 mm long axis is resting on one point of base circle on VP, while its axis makes 45° inclination with VP and FV of the axis 30° inclination with HP. Draw its projections.
10. A cone of base diameter 50 mm and height 60 mm is rests on the ground on a point of its base circle such that the axis of the cone inclined at 45° to the H.P. and inclined at 45° to the H.P. Draw its front and top views.
11. A hexagonal Prism having a base with a 40 mm side and 80 mm long axis, has an edge its base on the HP. The end containing that edge is inclined at 30° to the HP and axis parallel to the VP. It is cut a plane perpendicular to the VP and parallel to the HP. The cutting plane bisects the axis. and inclined at 45° to the HP. Draw its front and sectional top views.
12. A square pyramid of base side 30 mm and altitude 50 mm lies on one of its triangular faces on the HP with its axis parallel to the VP. It is cut by a vertical plane inclined at 30° to the VP and meeting the axis at 40 mm from the vertex measured in the plan. Draw the top view, sectional front view and the true shape of the section.
13. A cone, diameter of base 50 mm and axis 65 mm long .is lying on the HP on one of its generators with the axis parallel to the VP. It is cut by a horizontal Section plane 12 mm above the ground. Draw its front and sectional top views.
14. Draw the projections of a hexagonal pyramid of side of base 30mm and axis 60 mm long resting on one of its base edges in HP with its axis inclined at 30° to HP and the top view of axis is 45° to VP.
15. Draw the projections of a pentagonal prism, base 25 mm side and axis 50 mm long resting on one of its rectangular faces on HP, with the axis inclined at 45 degrees to VP.

Department of Mechanical Engineering



UNIT 4

DEVELOPMENT OF SURFACE



Department of Mechanical Engineering

In industrial world, an engineer is frequently confronted with problems where the development of surfaces of an object has to be made to help him to go ahead with the design and manufacturing processes. For example, in sheet metal work, it plays a vital role, thus enabling a mechanic to cut proper size of the plate from the development and then to fold at proper places to form the desired objects, namely, boilers, boxes, buckets, packing boxes, chimneys, hoppers, air-conditioning ducts etc.

“The development of surface of an object means the unrolling and unfolding of all surfaces of the object on a plane.”

“If the surface of a solid is laid out on a plain surface, the shape thus obtained is called the development of that solid.” In other words, the development of a solid is the shape of a plain sheet that by proper folding could be converted into the shape of the concerned solid.

Importance of Development:

Knowledge of development is very useful in **sheet metal work, construction of storage vessels, chemical vessels, boilers, and chimneys**. Such vessels are manufactured from plates that are cut according to these developments and then properly bend into desired shaped. The joints are then **welded or riveted**.

Principle of Development:

Every line on the development should show the true length of the corresponding line on the surface which is developed.

Methods of Development:

- (a) Parallel-line development
- (b) Radial-line development
- (c) Triangulation development
- (d) Approximate development

Parallel-line Method:

It is used for developing prisms and single curved surfaces like cylinders, in which all the edges/generation of lateral surfaces are parallel in each other.

Radial-line Method:

It is employed for pyramids and single curved surfaces like cones in which the apex is taken as center and the slant edge or generator as radius of its development.

Triangulation Method:

Department of Mechanical Engineering

It is used for developing transition pieces.

Approximate Method:

It is employed for double curved surfaces like spheres, as they are theoretically not possible to develop. The surface of the sphere is developed by approximate method. When the surface is cut by a series of cutting planes, the cut surfaces is called a zone.

Develop the surfaces of the cube of 1"

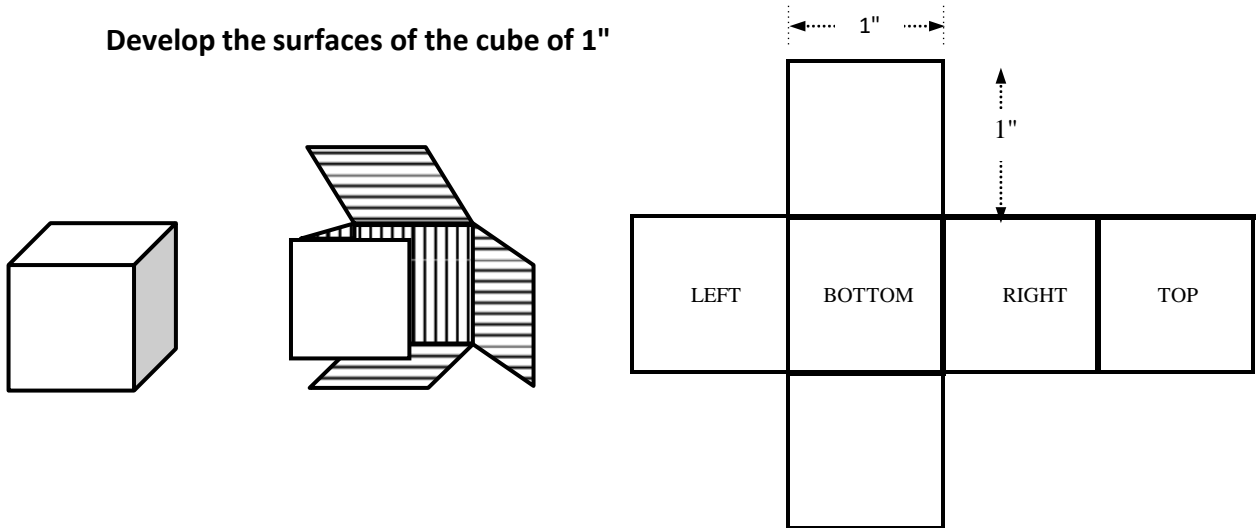

Develop the surfaces of a triangular prism

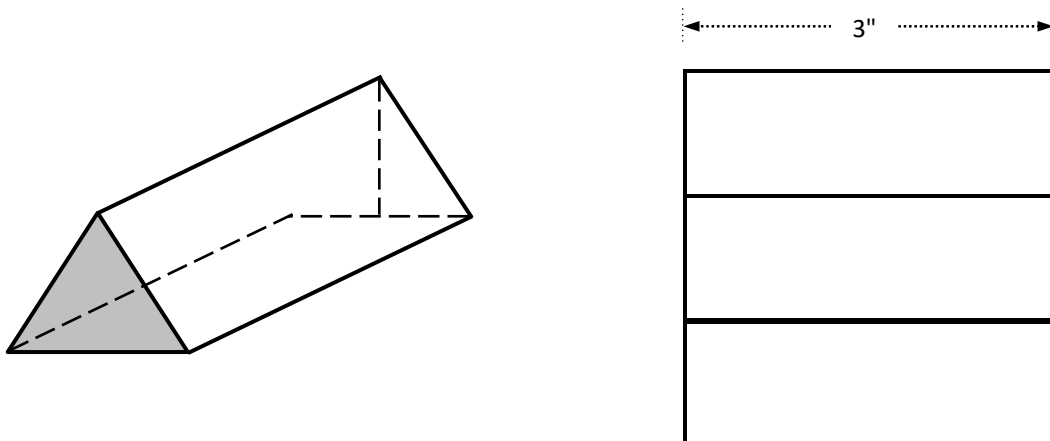

Department of Mechanical Engineering

Draw the development of a cone of diameter 1.5" and inclined height of 2"

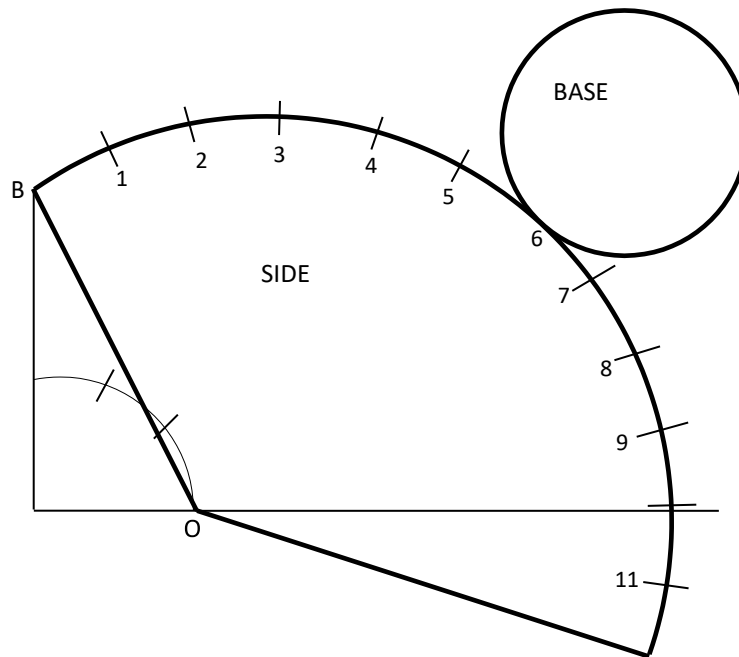

Draw the development of a square pyramid from its plan and front elevation which stands vertically on its base on H.P with one edge of the base parallel to V.P.

Department of Mechanical Engineering

A cone of base 50 mm diameter and height 65 mm rests with its base on H.P. A section plane perpendicular to

V.P and inclined at 30° to H.P bisects the axis of the cone. Draw the development of the lateral surface of the truncated cone.

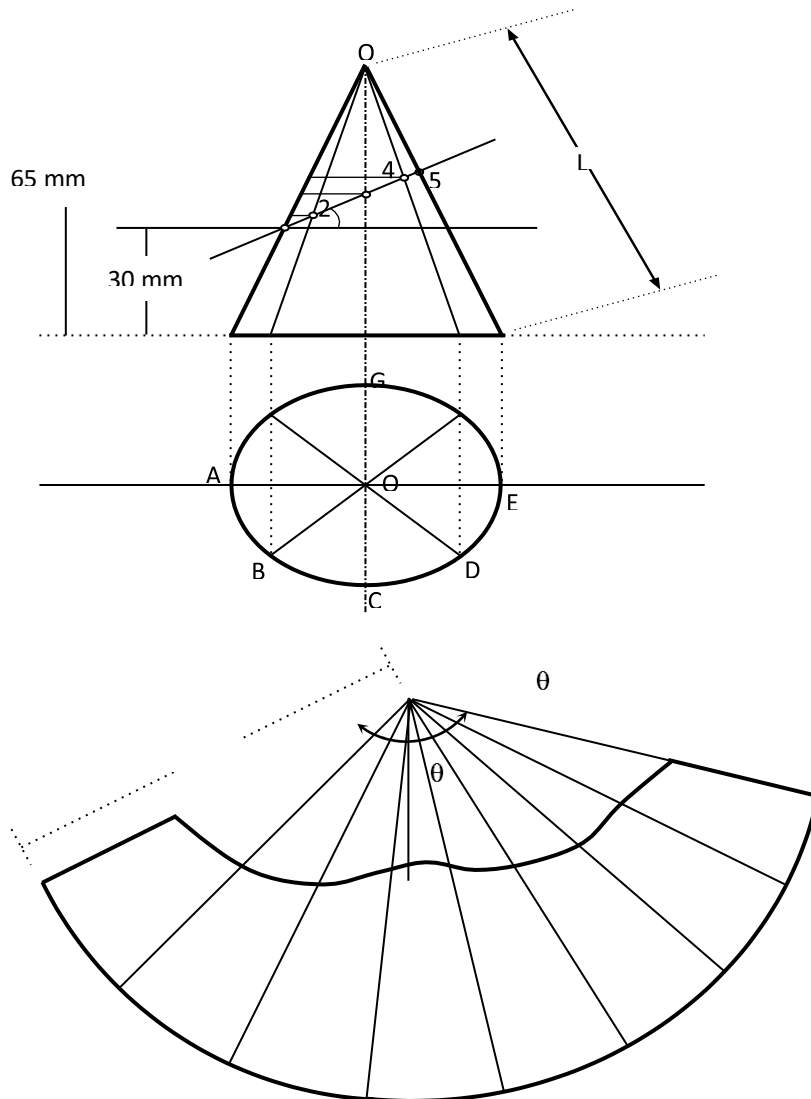

Department of Mechanical Engineering

A pentagonal pyramid, side of base 30 mm and height 60 mm, stands with its base on H.P and an edge of the base is parallel to V.P. It is cut by a plane perpendicular to V.P, inclined at 40° to H.P and passing through a point on the axis, 32 mm above the base. Draw the sectional top view and develop the lateral surface of the truncated pyramid.

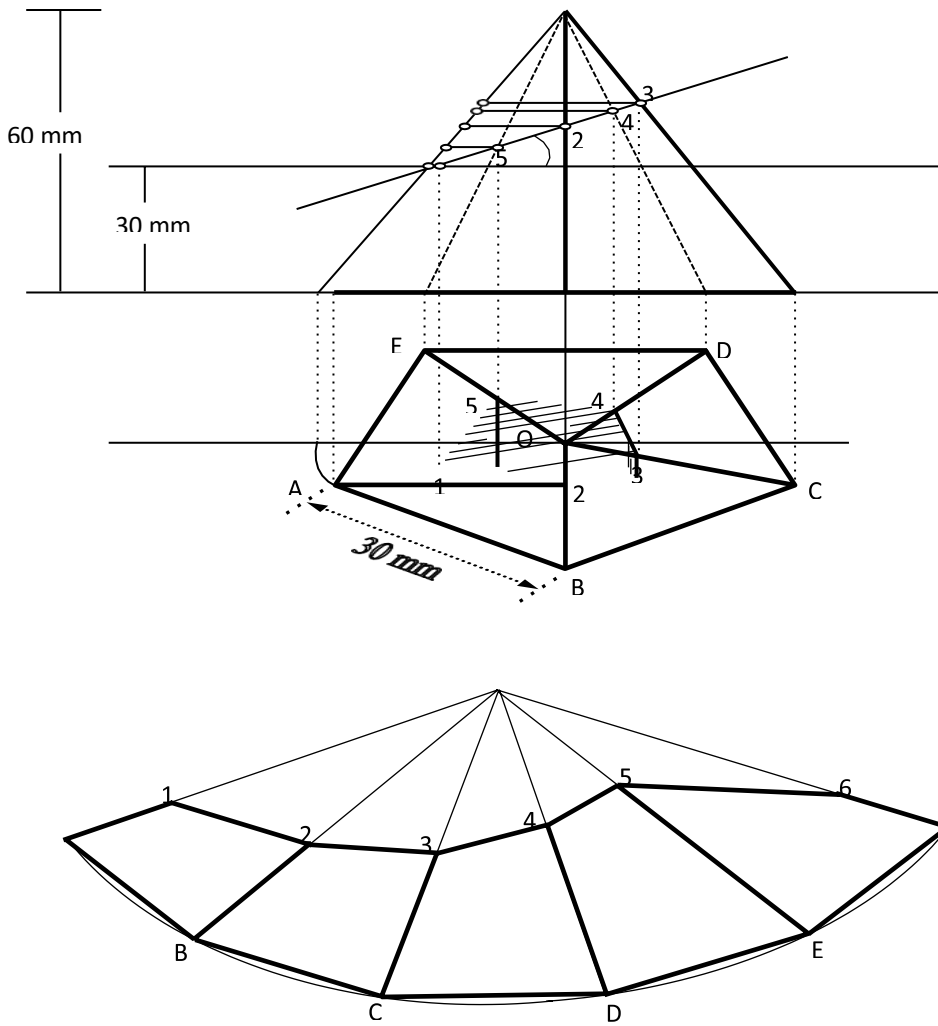

Department of Mechanical Engineering



UNIT 5

ISOMETRIC PROJECTION

Department of Mechanical Engineering

Isometric Projection

In engineering drawing, orthographic projection of a solid is best way of projecting the details of an object when a solid is resting in its simple position. As the front view or top view taken separately, gives an incomplete idea of the object, a pictorial projection is the best method to show the object in one view only. Basically, pictorial projection represents three dimensional shape of an object and represents real things in one view only, which indicates length, breadth and height of the object. Therefore, the object is easily visualized from a pictorial projection than from its orthographic projection.

The pictorial projection may be divided as:

1. Oblique projection
2. Perspective projection
3. Axonometric projection.

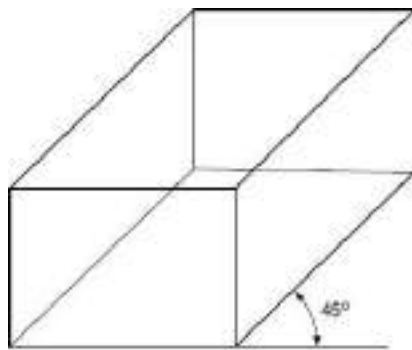

(i) Oblique Projection

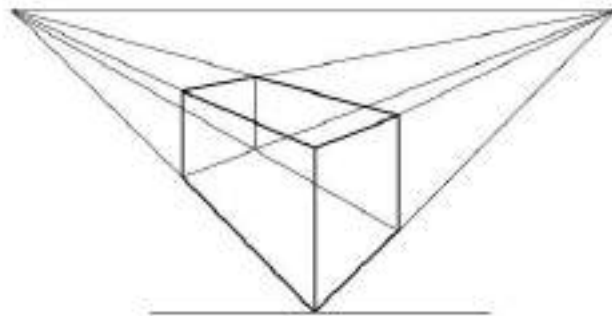

(ii) Perspective Projection

Axonometric Projection

An axonometric projection is a type of single-view parallel projection used to create a pictorial drawing of an object. The object is placed in such a position that the three mutually perpendicular faces are visible from a single direction. The word ‘axonometric projection’ means measuring along axis in which “axon” means axis while metron means measuring. Axonometric projections are commonly used to draw mechanical parts of an object for the clear picture of an object which are visualized from the orthographic projection. In this projection the object can be drawn at different angles and having the different length of edges.

Axonometric projections are again classified as:

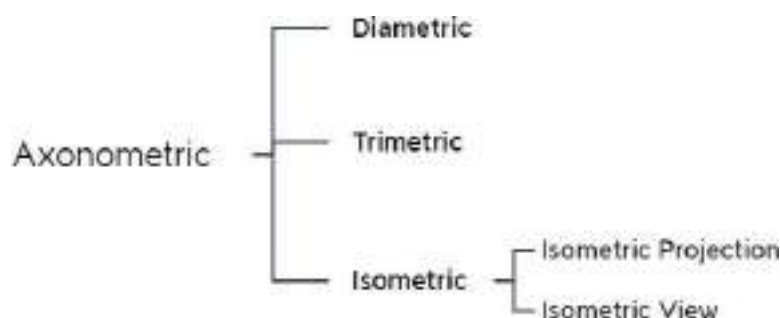

Department of Mechanical Engineering

Trimetric Projection

In this type, an object is placed in such a way that no two axes make an equal angle with the plane of projection.

Dimetric Projection

In this type of projection, an object is placed in such a way that two of its axes make equal angle with the plane of projection and the third axis makes either a smaller or a greater angle.

Isometric Projection

In this type of projection, an object is placed in such a way that all three axes make equal angle with the plane of projection.

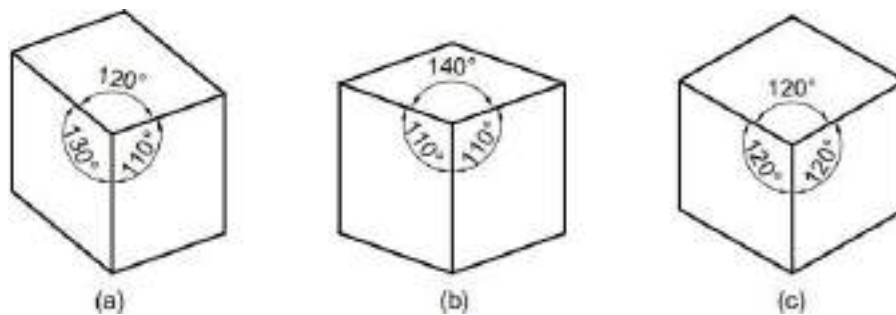

The isometric projection is the most common pictorial representation used in industries where visualization of the three dimensions of a solid are not only shown in one view, but their actual sizes can be measured directly from it. As it shows views of three faces of an object equally, it is very helpful to even a layman to understand the shape of the object. A multiview drawing requires two or more orthographic projections to define the exact shape of a three dimensional object. Each orthographic view is a two-dimensional drawing showing only two out of three dimensions of the object.

Principle of Isometric Projection

The isometric projection can be visualized is by considering a view of a cube with one of the solid diagonals perpendicular to the vertical plane and the three axes equally inclined to the vertical plane. The final front view is the isometric projection of the cube. Figure 15.3(a) shows the front view when hidden lines are removed. It gives the realistic view of the cube. The corners are renamed in capital letters. A keen study of this view reveals the following information.

1. The outer boundary ABFGHDA is a regular hexagon.
2. All the faces of the cube which are actually square in shape appear as rhombus.
3. The three lines CB, CD and CG meeting at C, represent the three mutually perpendicular edges of the cube.
 - a. They make equal angles of 120° with each other.
 - b. They are equal in length but smaller than the true length of the edge of the cube.
 - c. The line CG is vertical, and the other lines CB and CD make 30° with the horizontal.
4. All other lines representing the edges of the cube are parallel to one or the other of the abovethree lines, i.e., CB, CD and CG, and are equally foreshortened.
5. The diagonal BD of the top face ABCD is parallel to V.P., and hence shows its true length.

A comparison of the rhombus ABCD of the front view with the square face of the cube is shown in below figure.

Department of Mechanical Engineering

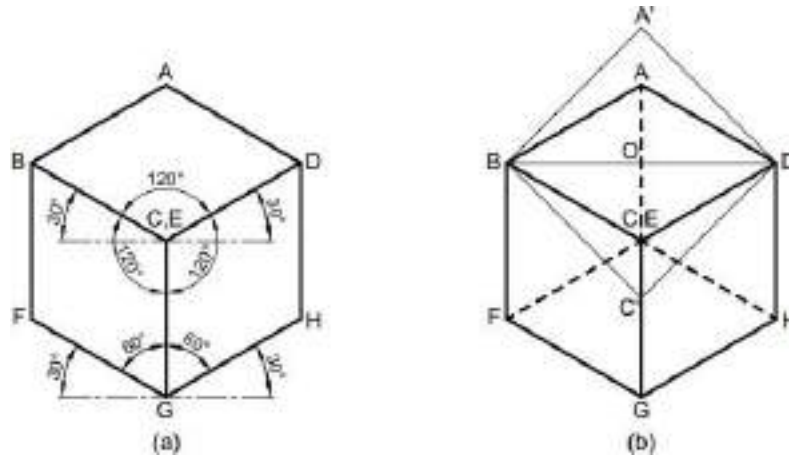

Isometric Axes, Lines and Planes

1. The three lines CB, CD, CG meeting at a point C and making an angle of 120° with each other are called **Isometric axes**.
2. The lines (AB, BF, FG, GH, DH and AD) parallel to the Isometric axis are termed as **Isometric lines**.
3. The lines (BD, AC, CF, BG, etc.,) which are not parallel to the isometric axes are known as **Non-Isometric lines**
4. The plane (ABCD, BCGF, CGHD, etc.,) representing any face of the cube as well as other plane parallel to it is called an **Isometric Plane**.
5. The plane (ABGH, CDEF, AFH, CFH, etc.,) which is not parallel to isometric planes are known as **Non-Isometric Planes**.
6. The scale which is used to convert the true length into isometric length is known as **Isometric Scale**.

Isometric Scale

Referring to the above Fig., all the edges of the cube are equally foreshortened. Therefore, the square faces are seen as rhombuses in the isometric projection. The foreshortening of the edge can be calculated as follows:

$$\text{In triangle ABO, } \frac{BA}{BO} = \frac{1}{\cos 30^\circ} = \frac{2}{\sqrt{3}}$$

$$\text{In triangle A'BO, } \frac{BA'}{BO} = \frac{1}{\cos 45^\circ} = \frac{\sqrt{2}}{1}$$

$$\text{Therefore, } \frac{\text{Isometric length}}{\text{True length}} = \frac{BA}{BA'} = \frac{2}{\sqrt{3}} \times \frac{1}{\sqrt{2}} = \frac{2}{\sqrt{6}}$$

Department of Mechanical Engineering

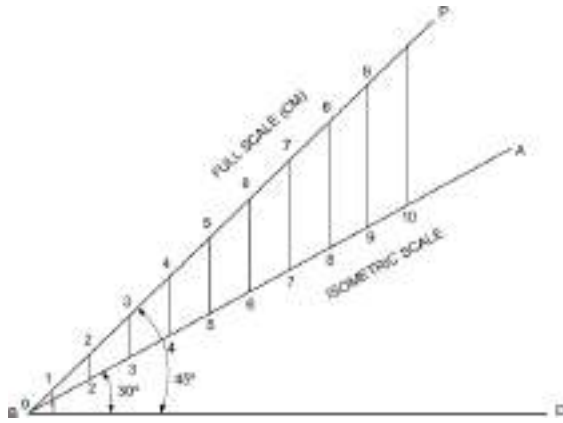

Conventional Isometric Scale

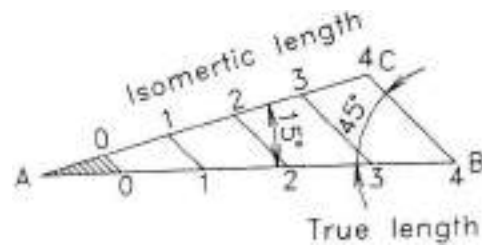

Simplified Isometric Scale

This reduction of the true length can be obtained either by multiplying it by a factor 0.816 or by taking the measurement with the help of an isometric scale.

Isometric Projection and View

Isometric projection of an object is the front view of the object placed in isometric position. Isometric projection is the actual projection of the object on V.P. Here as the edges of the transparent cube are inclined $35^{\circ}16'$ to V.P., their projection on VP will have a length of about 82% of the true length, when measured in the isometric position.

Isometric projection can be drawn directly, using the true length of the edges of the cube along the isometric axes. As a result, the projection obtained is larger in size than the actual. This projection is called isometric View or Isometric Drawing.

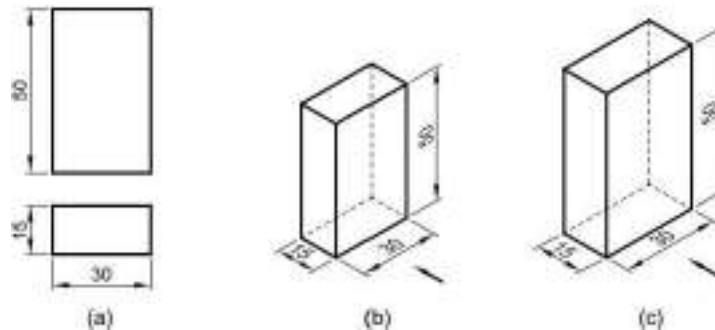

(a) Multiview projection (b) Isometric projection (c) isometric view

Dimensioning

The general rules for the dimensioning of multi view projection is applicable for isometric projection, except the following:

1. All the extension lines and dimension lines should be parallel to the isometric axes and they should be on any of the isometric planes.
2. The text should be placed at the middle of the dimension line, after breaking it to a short length.
3. The dimensional values in X direction should be readable from the right side. While the Y direction from left side and Z direction from the right side respectively.
4. The numerals placed along the three axes should be aligned with the direction of the axes.

Department of Mechanical Engineering

System of Notation

1. The actual solid in space is denoted by capital letters A1 , B1, C1 and D1 etc for Base of solid and A, B, C and D etc for top face of the solid and axis as o1 and o.
2. The front view (FV) of a solid is denoted by their corresponding lower case letters with dashes as a1', b1', c1' and d1' etc for base of solid and a', b' c' and d' etc for top face of the solid and for axis as o1' and o'.
3. The top view (TV) of a solid is denoted by their corresponding lower case letters with dashes as a1, b1, c1 and d1 etc for bottom of solid and a, b c and d etc for top face of the solid and for axis as o1 and o.
4. Projectors are always drawn as continuous thin lines.
5. Isometric projection annotations are made with the corresponding letters of the solid.
6. Line with specific thickness for a particular type of line.

Isometric Drawing using AutoCAD

In Computer Aided Engineering Graphics for isometric projections following commands are used other than evoking software, opening file, saving file and giving print command. A 2D isometric drawing is a flat representation of a 3D isometric projection. This method of drawing provides a fast way to create an isometric view of a simple design. Distances measured along an isometric axis are correct to scale, but the 3D distances and areas cannot be extracted since the drawings will be in 2D, display objects from different viewpoints, or remove hidden lines automatically.

By using the ISODRAFT command, several system variables and settings are automatically changed to values that facilitate isometric angles. Isoplane specifies the current isometric plane. The standard isometric planes, called **isoplanes**, are as follows:

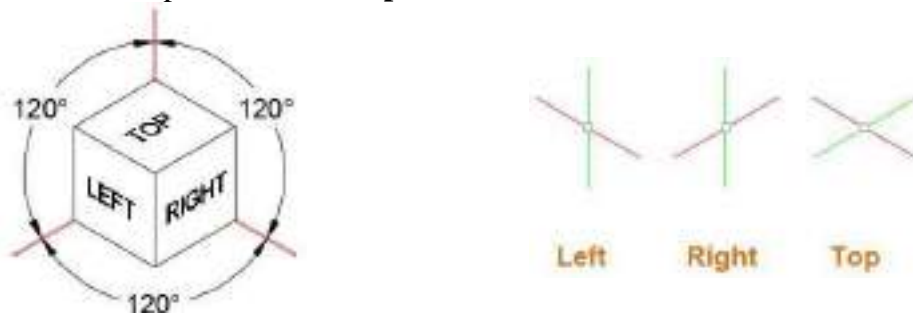

- Right.: Selects the right-hand plane, defined by the 30- and 90-degree axes pair
- Left: Selects the left-hand plane, defined by the 90- and 150-degree axes pair.
- Top: Selects the top face, called the top plane, defined by the 30- and 150-degree axispair.

You can use the Isometric Drafting tool on the status bar to select the desired isoplane. Alternatively, you can press F5 or Ctrl+E to cycles through the isoplanes.

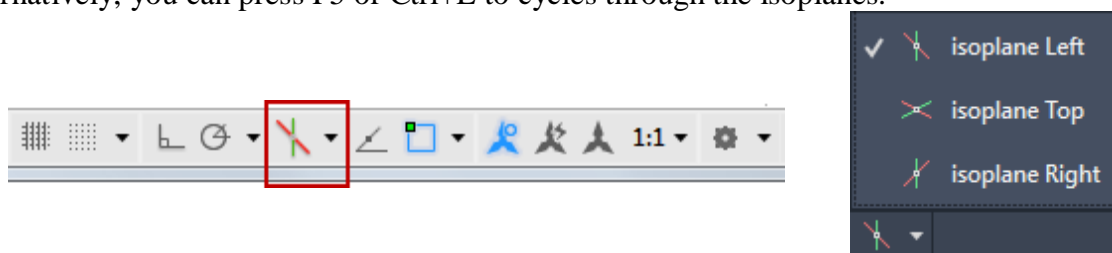

Department of Mechanical Engineering

Using these following commands and features are the most commonly used ones to maintain precision in isometric drawings:

- Polar tracking and direct distance entry
- Object snaps and grid snaps
- Object snap tracking
- Move and Copy

Extrude

The EXTRUDE command creates a solid or surface that extends the shape of a curve. Open curves create surfaces and closed curves create solids or surfaces

When you extrude objects, you can specify any of the following options:

Mode. Sets whether the extrude creates a surface or a solid.

Specify a path for extrusion. With the Path option, create a solid or surface by specifying an object to be the path for the profile, or shape, of the extrusion. The extruded object starts from the plane of the profile and ends on a plane perpendicular to the path at the endpoint of the path. For best results, use object snaps to make sure that the path is on or within the boundary of the object being extruded.

Taper angle. Tapering the extrusion is useful for defining part that require a specific taper angle, such as a mold used to create metal products in a foundry.

Direction. With the Direction option, you can specify two points to set the length and direction of the extrusion.

Expression. Enter a mathematical expression to constrain the height of the extrusion.

Revolve

Open profiles create surfaces and closed profiles can create either a solid or a surface. The MODOption controls is a solid of surface is created. When creating a surface, SURFACEMODELINGMODE system variable controls if a procedural or NURBS surface is created.

Revolve path and profile curves can be:

- Open or closed
- Planar or non-planar
- Solid and surface edges
- A single object (to extrude multiple lines, convert them to a single object with the JOINcommand)
- A single region (to extrude multiple regions, first convert them to a single object withthe UNION command)

The following are the options for revolving:

Objects to Revolve

Specifies the objects to be revolved about an axis.

Department of Mechanical Engineering

Mode

Controls whether the revolve action creates a solid or a surface. Surfaces are extended as either NURBS surfaces or procedural surfaces, depending on the SURFACEMODELINGMODE system variable.

Axis Start Point

Specifies the first point of the axis of revolution. The positive axis direction is from the first to the second point.

Axis Endpoint

Sets the endpoint for the axis of revolution.

Start Angle

Specifies an offset for the revolution from the plane of the object being revolved.

Angle of Revolution

Specifies how far the selected object revolves about the axis.

Loft

Creates a 3D solid or surface by specifying a series of cross sections. The cross sections define the shape of the resulting solid or surface. Loft cross sections can be open or closed, planar or non-planar, and can also be edge subobjects. Open cross sections create surfaces and closed cross sections create solids or surfaces, depending on the specified mode.

The following prompts are used under loft:

Cross Sections in Lofting Order

Specifies open or closed curves in the order in which the surface or solid will pass through them.

Point

Specifies first or last point of the lofting operation. If you start with the Point option, you must next select a closed curve.

Join Multiple Edges

Handles multiple, end-to-end edges as one cross section.

Mode

Controls whether the lofted object is a solid or a surface.

Continuity

This option only displays if the LOFTNORMALS system variable is set to 1 (smooth fit). Specifies whether the continuity is G0, G1, or G2 where the surfaces meet.

Bulge Magnitude

This option only displays if the LOFTNORMALS system variable is set to 1 (smooth fit). Specifies a bulge magnitude value for objects that have a continuity of G1 or G2.

Guides

Specifies guide curves that control the shape of the lofted solid or surface. Guide curves can be used to control how points are matched up on corresponding cross sections to prevent undesired results, such as wrinkles in the resulting solid or surface.

Department of Mechanical Engineering

Problem:

1. Draw the isometric view of a Circle (Isocircle) with a 60mm Diameter on all three Principle Planes Using Co-ordinate methods?

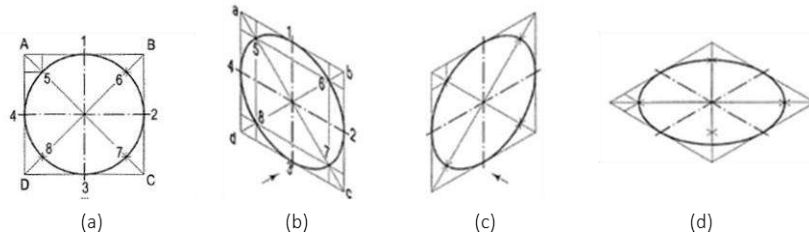

Solution:

1. Do one of the following:
 - On the status bar, click  Find.
 - At the Command prompt, enter ISODRAFT.
 2. Choose which isoplane orientation that you want to use: Left, Right, or Top.
 - Press F5 or Ctrl+E to cycle through the different isoplanes
 - On the status bar, Isodraft button, click the dropdown arrow and choose an option
 - At the Isodraft prompt in the Command window, enter an option
 3. At the Command prompt, enter ELLIPSE.
 4. At prompt, enter i (Isocircle).
 5. The Isocircle option is available only when an isometric drawing plane is active.
 6. Specify the center of the isocircle.
 7. Specify the radius or diameter of the isocircle.
2. Draw the isometric view of a square of side 40mm kept in (a) vertical Position and (b) horizontal position

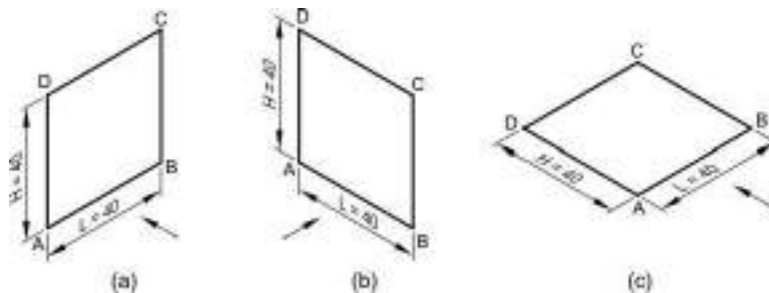

Solution:

1. Do one of the following:
 - On the status bar, click  Find.
 - At the Command prompt, enter ISODRAFT.
2. Choose which isoplane orientation that you want to use: Left, Right, or Top.
 - Press F5 or Ctrl+E to cycle through the different isoplanes
 - On the status bar, Isodraft button, click the dropdown arrow and choose an option
 - At the Isodraft prompt in the Command window, enter an option
3. At the Command prompt, enter Line.
4. The Polyline option is available only when an isometric drawing plane is active.
5. Specify the coordinates of the square to draw the square.

Department of Mechanical Engineering

3. Draw the isometric view of a square prism of base side 40 mm and axis 60 mm resting on the H.P. on the (a) base with axis perpendicular to the H.P., (b) rectangular face with axis perpendicular to the V.P., and (c) rectangular face with axis parallel to the V.P.

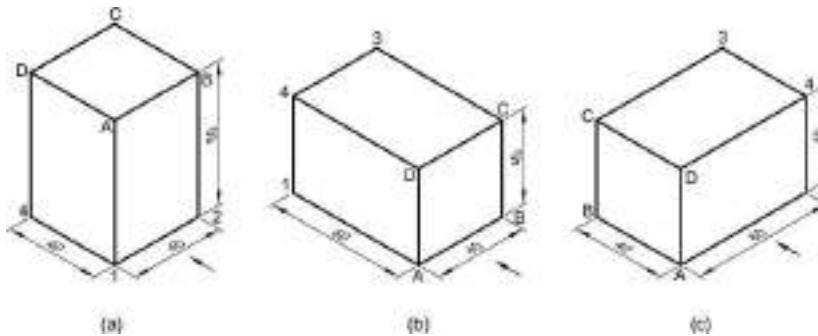

Solution:

- At first, you need to change your snap settings to isometric. Type DS on the command line and press enter.
 - Drafting settings window will pop up from this window select snap and grid tab and make sure Isometric snap radio button is checked. Click OK to exit drafting settings window.
 - Now make sure ortho mode is turned on from the status bar, if it is not turned on then press F8 to turn it on.
 - You can now select isometric plane for your drawing by pressing the F5 key. The three Isoplanes available for selection are Isoplane top, right and left.
 - Press F5 key to activate Isoplane top and then select line command and click anywhere in the drawing area to start your line. Specify a direction and type 5 on the command line then press enter, repeat this process by changing directions of line to make a closed square
4. A cone of base diameter 30mm and height 40mm rests centrally over a cube of side 50mm. Draw the isometric projection of combination of solids.

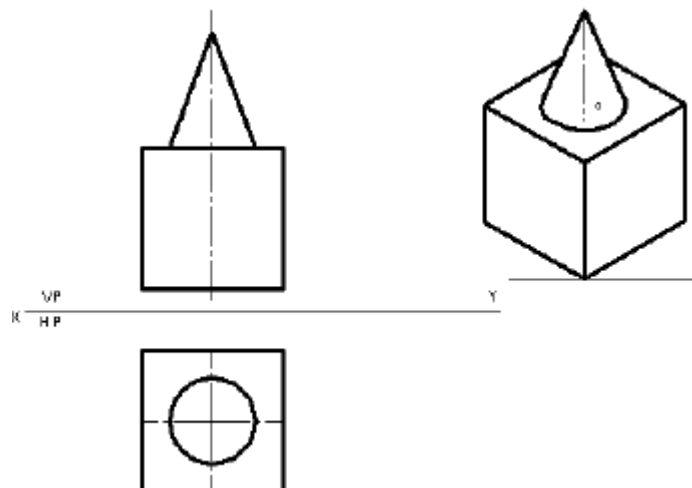

Solution:

- Open the SOFTWARE. Click on the DRAWING in the open dialog box and say OK.
- To set up the sheet of required size (Ex: A4) by selecting TOOLS from Main Menu Bar and click on OPTIONS/PROPERTIES. Select document properties in dialog box appeared and then select drawing in selection panel. Select the required size say A4, and click OK.

Department of Mechanical Engineering

3. As per the problem draw top and front view of combined solids using suitable commands.
 4. Draw the isometric scale, as per the dimensions of the problem using **POLYLINE** command and in format select PL for construction lines draw two lines of iso length of 50 mm along 30° line as shown. Draw another two lines, using **PARALLEL LINE COMMAND** and using **TRIM/EXTEND CURVES**, so that they are connected systematically.
 5. Draw the vertical lines at corners of parallelogram equal to isometric height of square prism of 50 mm using POLYLINE command and in format select VL.
 6. Join all the top end points using 2 POINT LINE Command and in format select PL to get top face as shown below.
 7. Since the axis of solids is collinear (square prism and cone), identify the center of rectangle represent it as o. With o as center construct a box of iso length of side 30 mm similar to base drawn earlier as shown using POLYLINE command and in format select PL.
 8. Using 3 POINT CIRCLE command in drafting tool bar. In mode option select arc, and use three center method draw an ellipse to get the bottom of cone.
 9. Using POLYLINE command and in format select AL draw vertical line upwards at the center of rectangle, equal to the height of cone 40 mm (given) to get apex of the cone.
 10. Using POLYLINE command and in format select VL draw tangential line from bottom of cone to apex as shown. Trim all the unwanted construction lines by using SMART DELETE COMMAND.
 11. Using SMART DIMENSION Command in drawing tool bar dimension the drawing as shown. To get a Hard Copy of the standard drawing select print from file menu bar. Print dialog window will appear select page and change width to Entities and select the activated button now substitute width 1 as 0.15 mm, width 2 as 0.05 mm, width 3 as 0.5mm, width 4 as 0.35 mm and say OK. Select print to get a hard copy and finally save the file. The required standard drawing is as shown below.
5. A hemisphere diameter 50mm is resting on its curved surface centrally on the top face of frustum of a rectangular pyramid base 80mm x 60mm and top 60mm x 40mm, height 55mm. Draw the isometric projection of combined solids.

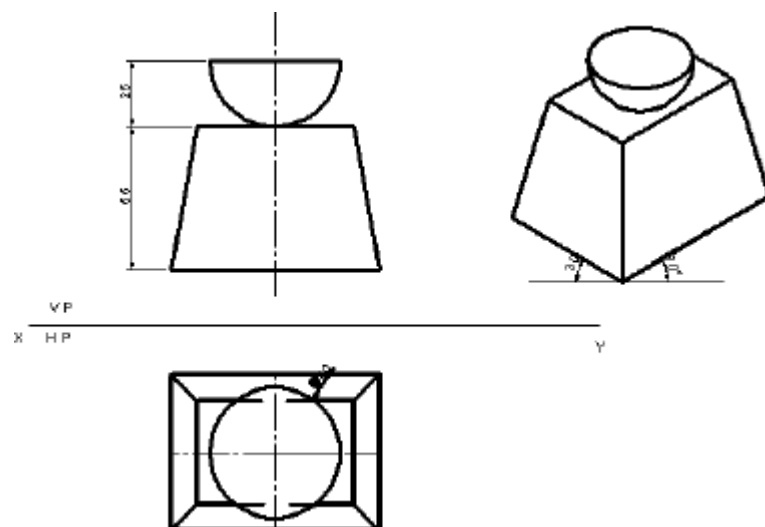

Department of Mechanical Engineering

Solution:

1. Open the **SOFTWARE**. Click on the **DRAWING** in the open dialog box and say **OK**.
2. To set up the sheet of required size (Ex: A4) by selecting **TOOLS** from Main Menu Bar and click on **OPTIONS/PROPERTIES**. Select document properties in dialog box appeared and then select drawing in selection panel. Select the required size say A4, and click **OK**.
3. As per the problem draw top and front view of combined solids using suitable commands.
4. Draw the isometric scale, as per the dimensions of the problem.
5. Using **POLYLINE** command and in format select VL for visible edges draw two lines of iso length of 80 mm and 60 mm along 30° line as shown. Draw another two lines, using **PARALLEL LINE COMMAND** and using **TRIM/EXTEND CURVES** so that, they are connected systematically.
6. Using **POLYLINE** command and in format select AL draw vertical line upwards at the center of rectangle, equal to the height of rectangular frustum 55 mm (given).
7. At top end of vertical line drawn, using **POLYLINE** command and in format select VL for visible edges draw two lines of iso length of 60 mm and 40 mm along 30° line as shown. Draw another two lines, using **PARALLEL LINE COMMAND** and using **TRIM/EXTEND CURVES** so that, they are connected systematically.
8. Join all the relevant corners of top to base frustum using 2 **POINT LINE** command and in format select VL to get frustum as shown below.
9. Since the axis of solids is collinear (hemisphere and rectangular pyramid), identify the center of rectangle represent it as o. With o as center using **POLYLINE** command and in format select AL draw vertical line upwards at the center o of height equal to height of hemisphere 25 mm (given). Construct a box of iso length of side 50 mm to fit top face of hemisphere using **POLYLINE** command and in format select PL.
10. Using 3 **POINT CIRCLE** command in drafting tool bar. In mode option select arc, and select 3 points on rectangle draw a top face of hemisphere.
11. Using **CENTER CIRCLE** command in drafting tool bar. In mode option select arc, with center as center of top face of hemisphere and radius as actual radius of hemisphere draw an arc, so that it touches the top face of hemisphere and passes through the center of top face of the rectangle frustum.
12. Trim all the unwanted construction lines by using **SMART DELETE COMMAND**. Using **SMART DIMENSION** command in drawing tool bar dimension the drawing as shown. To get a Hard Copy of the standard drawing select print from file menu bar. Print dialog window will appear select page and change width to Entities and select the activated button now substitute width 1 as 0.15 mm, width 2 as 0.05 mm, width 3 as 0.5mm, width 4 as 0.35 mm and say OK. Select print to get a hard copy and finally save the file. The required standard drawing is as shown below.

Department of Mechanical Engineering**Practice Exercises:****Plane Surface**

1. Draw the isometric view of a hexagon of side 30 mm whose surface is parallel to the V.P. and a side perpendicular to the H.P.
2. Draw isometric views of a triangle of sides 80 mm, 60 mm and 50 mm on all the three principal planes.
3. Draw the isometric view of a cube of side 50 mm. Also show in the view, circles of diameter 50 mm marked on all the visible faces of the cube.
4. Draw isometric view of a hexagonal plane of side 40 mm with a central hole of diameter 40 mm when the surface of the plane is parallel to the H.P.
5. Draw isometric view of a composite plane made up of a rectangle of sides 60 mm and 40 mm with a semicircle on its longer side.

Simple Solid

1. Draw the isometric view of a cylinder of base diameter 50 mm and axis 60 mm lying on one of its generators on the H.P.
2. A square prism of base edge 40 mm and axis 60 mm has an edge of its base on the H.P. The axis is parallel to the V.P. and inclined at 30° to the H.P. Draw its isometric view.
3. Draw an isometric view of a pentagonal prism of base side 30 mm and axis 60 mm resting on its base in the H.P. with a face parallel and nearer to the V.P.
4. A pentagonal pyramid of base side 30 mm and axis 60 mm long is resting on a face on the H.P. with axis parallel to the V.P. Draw its isometric view in the stated condition.

Truncated Prism

1. Draw isometric projection of the frustum of a pentagonal pyramid of base side 40 mm, top side 20 mm and height 35 mm resting on its base on the H.P.
2. A triangular pyramid having a base 50 mm side and axis 65 mm long is resting on its base in the H.P. with a side of the base parallel to the V.P. It is cut by an A.I.P. inclined at 45° with the H.P. and bisecting the axis. Draw its isometric view.
3. A paper weight is in the form of a sphere of diameter 50 mm truncated by a horizontal plane at a distance of 40 mm from the topmost point of the sphere. Draw its isometric projection.

Combined Solids

1. A cone of base diameter 30 mm and axis 50 mm rests centrally over a square prism of base side 50 mm and axis 30 mm. Draw the isometric projection of the arrangement.
2. A spherical ball of diameter 60 mm is placed centrally over a square block of side 60 mm and thickness 30 mm. Draw the isometric view of the arrangement.
3. A hexagonal prism of base side 30 mm and axis 50 mm has an axially drilled circular hole of diameter 30 mm. Draw its isometric projection.

Department of Mechanical Engineering



TRANSFORMATION OF PROJECTIONS



Department of Mechanical Engineering

Transformation of Projections

Introduction

Projection: Projection is defined as an Image or drawing of the object made on a plane. The lines from the object to the Plane are called projectors.

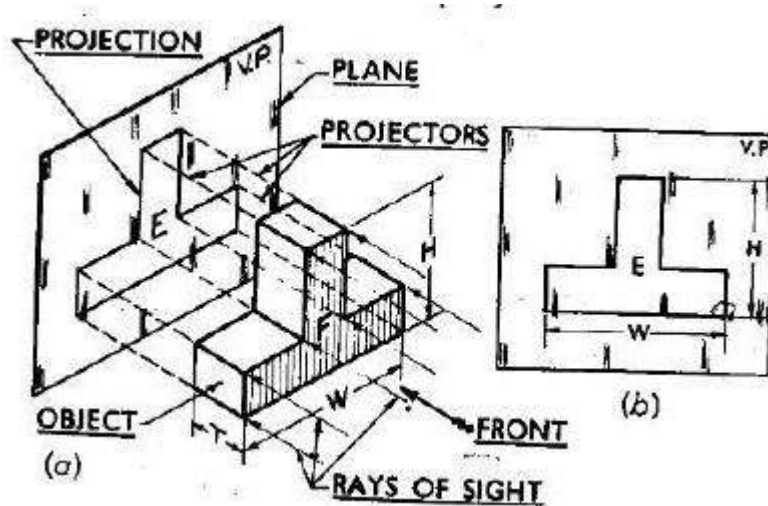

Methods of Projections: In Engineering drawing the following four methods of Projection are commonly used they are

- Orthographic Projection
- Isometric projection
- Oblique projection
- Perspective Projection

In orthographic projection an object is represented by two or three views on the mutual perpendicular projection planes each projection view represents two dimensions of an object.

In iso, oblique and perspective projections represents the object by a pictorial view as eyes see it. In these methods of projects in three dimensional object is represented on a projection plane by one view only.

Orthographic Projection

When the Projectors are parallel to each other and also perpendicular to the plane the projection is called orthographic Projection

Example: Orthographic projection of a car shown in below figure

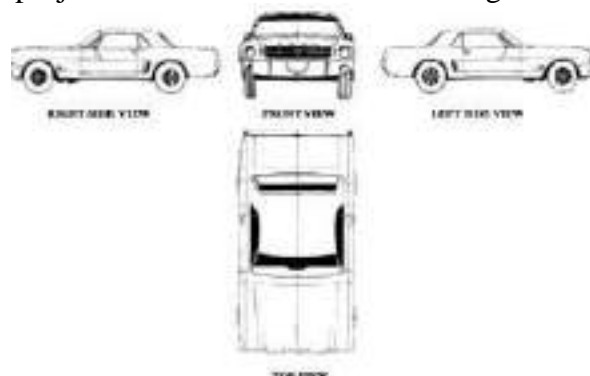

Department of Mechanical Engineering

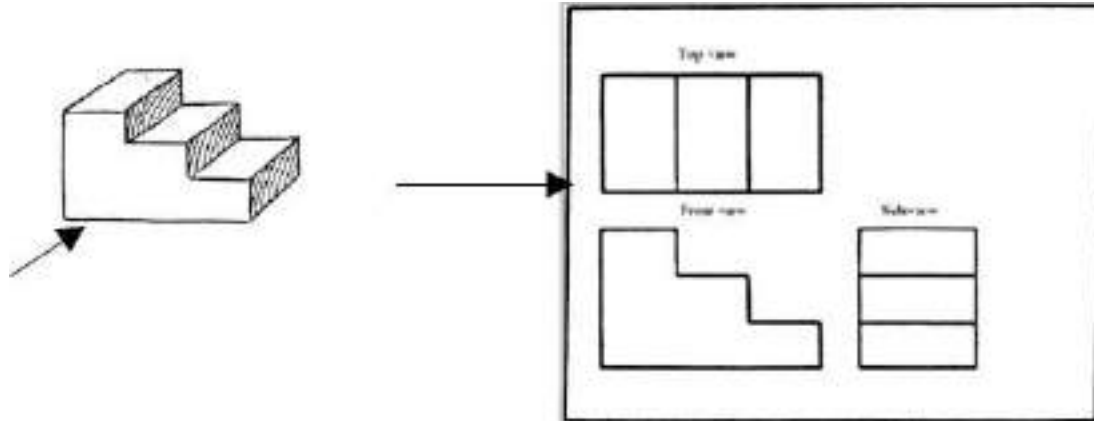

Orthographic Projection is a way of drawing an 3D object from different directions. Usually a front, side and plan view is drawn so that a person looking at the drawing can see all the important sides. Orthographic drawings are useful especially when a design has been developed to a stage where by it is almost ready to manufacture.

Plane of projection: Two planes employed for the purpose of orthographic projections are called reference planes or planes of projection. They are intersecting each other at right angle to each other the vertical plane of projection is usually denoted by the letters VP and the other Plane is horizontal plane of Projection is denoted by HP. The line in which they intersect is termed as the reference line and is denoted by the letters XY.

Problems

1. The front and top views of a casting are shown in Fig. Draw its isometric view.

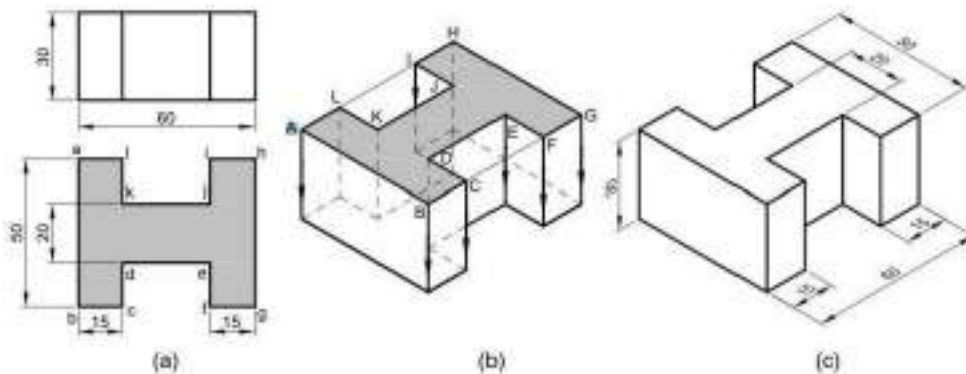

2. The front and top views of a casting are shown in Fig. Draw its isometric view

Department of Mechanical Engineering

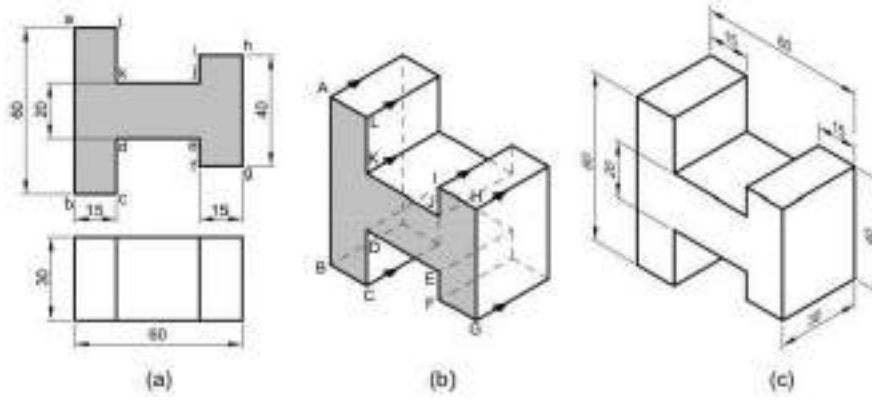

3. The front and top views of an angle plate are shown in Fig. Draw its isometric view.

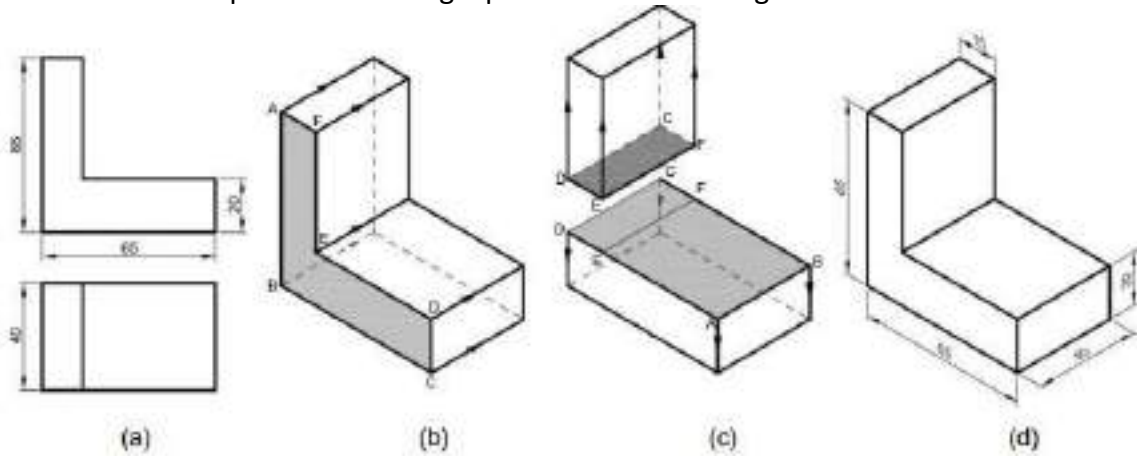

4. The front and top views of an angle plate are shown in Fig. Draw its isometric view.

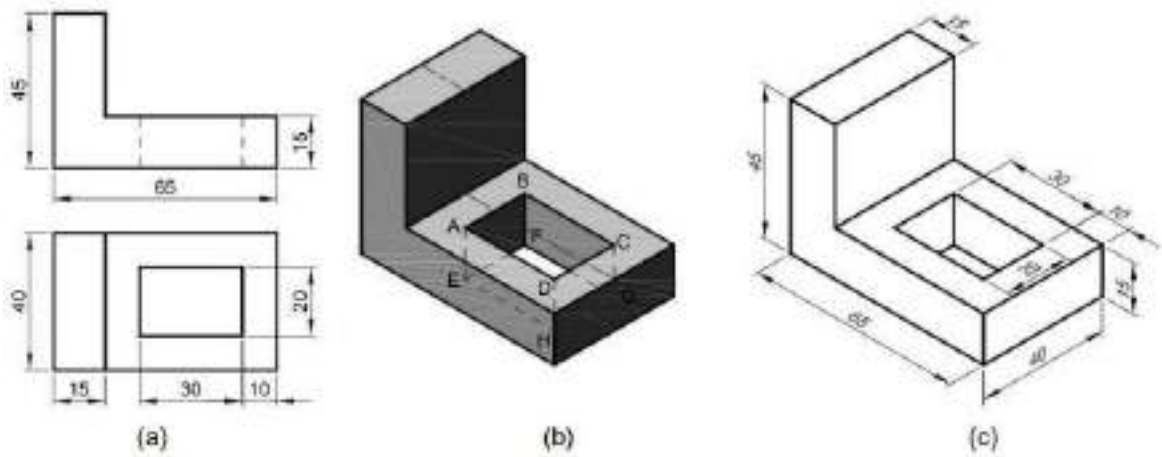

Department of Mechanical Engineering

5. The front and top views of an angle plate are shown in Fig. Draw its isometric view.

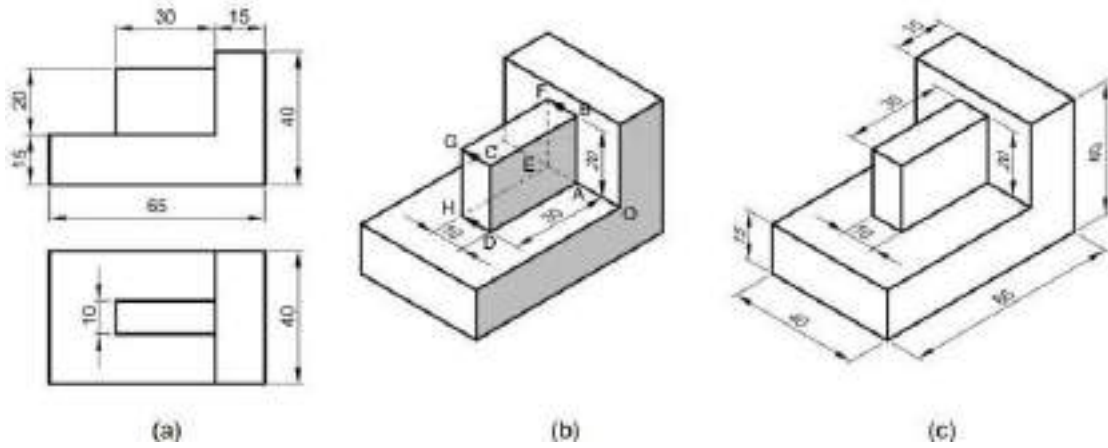

6. The front and side views of an angle plate are shown in Fig. Draw its isometric view.

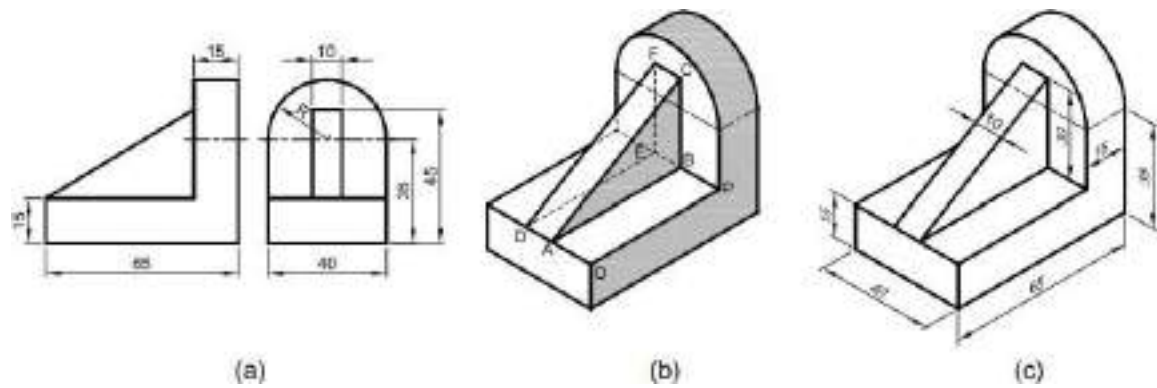

7. The front and top views of a casting are shown in Fig. Draw its isometric view.

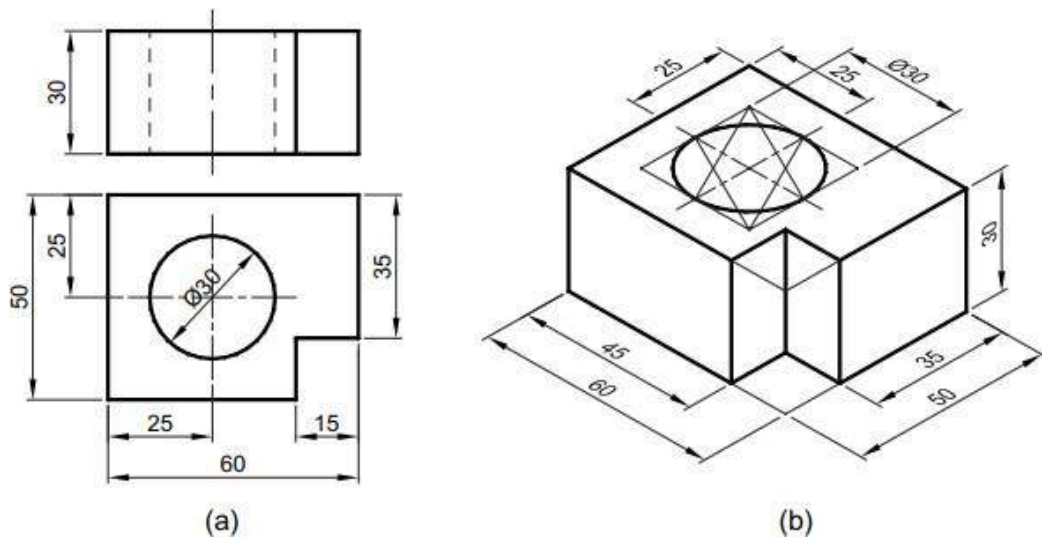

Department of Mechanical Engineering

Solved Problems

- To generate 3D Wireframe model as shown in figure, using 3D Absolute Coordinate Method and 3D Rectangular Coordinate Method.

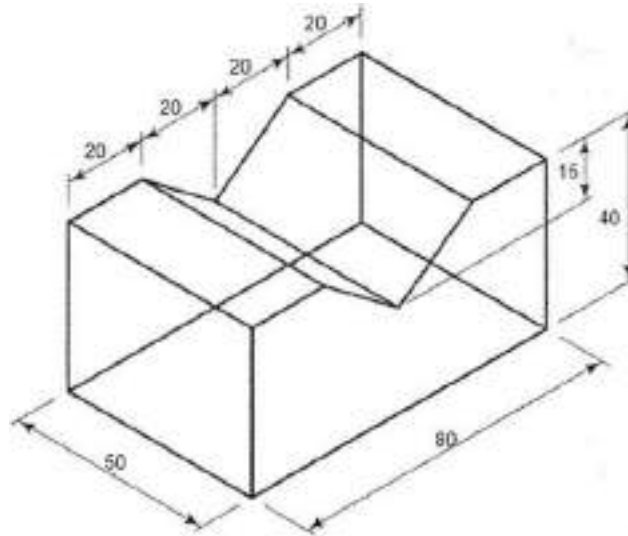

Solution

Command: -VPOINT ()

- Current view direction: VIEWDIR=0.0000, 0.0000, 1.0000
- Specify a view point or [Rotate] <display compass and tripod>: 1,-1,1 ()
 - Regenerating

model.Command: UCS ()

- Current ucs name: *WORLD*
 - Enter an option [New/Move/orthoGraphic/Prev/Restore/ .. ./World] <World>:() Command: ZOOM ()
- Specify corner of window, enter a scale factor (nX or nXP), or [All/Center/Dynamic/Extents/Previous/Scale/ ...] < real time>: ALL ()

Command: LINE ()

- Specify first point: 0,0,0 ()
- Specify next point or [Undo]: 50,0,0 ()
- Specify next point or [Undo]: 50,80,0 ()
- Specify next point or [Close/Undo]: 0,80,0 ()
 - Specify next point or [Close/Undo]: C () Command: LINE ()
- Specify first point: 50,0,0 ()
- Specify next point or [Undo]: @0,0,40 ()
- Specify next point or [Undo]: @0,20,0 ()
- Specify next point or [Close/Undo]: @0,20,-15 ()
- Specify next point or [Close/Undo]: @0,20, 15 ()
- Specify next point or [Close/Undo]: @0,20,0 ()

Department of Mechanical Engineering

- Specify next point or [Close/Undo]: @0,0,-40 ()
 - Specify next point or [Close/Undo]: () Command: LINE()
- Specify first point: 0,0,0 ()
- Specify next point or [Undo]: @0,0,40 ()
- Specify next point or [Undo]: @0,20,0 ()
- Specify next point or [Close/Undo]: @0,20,-15 ()
- Specify next point or [Close/Undo]: @0,20, 15 ()
- Specify next point or [Close/Undo]: @0,20,0 ()
- Specify next point or [Close/Undo]: @0,0,-40 ()
- Specify next point or [Close/Undo]: ()

Command: _qsave

Command: _dimaligned

Specify first extension line origin or <select object>:

Specify second extension line origin:

Command: _dimlinear

Specify first extension line origin or <select object>:

Specify second extension line origin:

Specify dimension line location or [Mtext/Text/Angle/Horizontal/Vertical/Rotated]:

Dimension text = 48.0000

Command: _dimedit

Enter type of dimension editing [Home/New/Rotate/Oblique] <Home>: _o

Select objects: 1 found

Enter obliquing angle (press ENTER for none): 30

Command: _qsave

Department of Mechanical Engineering

2. Draw the following figure using ACAD

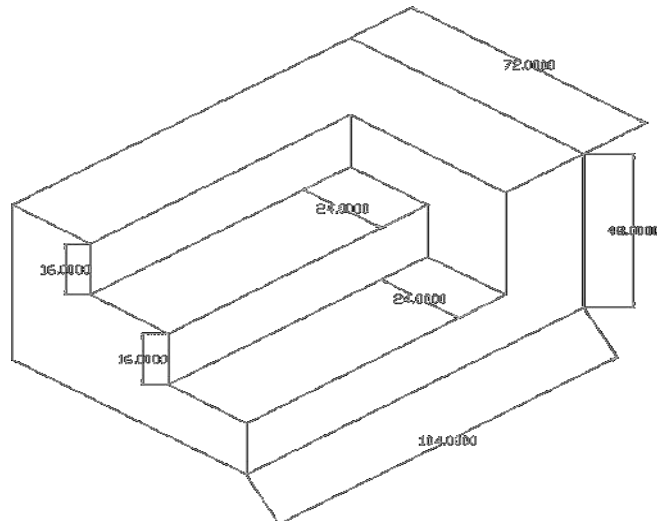

Solution

COMMANDS USED

Line, Dimensions, Drafting commands

PROCEDURE

Command: -VPOINT ()

- Current view direction: VIEWDIR=0.0000, 0.0000, 1.0000
- Specify a view point or [Rotate] <display compass and tripod>: 1,-1,1 ()
 - Regenerating

model.Command: UCS ()

- Current ucs name: *WORLD*
 - Enter an option [New/Move/orthoGraphic/Prev/Restore/ .. ./World] <World>:() Command: ZOOM ()
- Specify corner of window, enter a scale factor (nX or nXP), or [All/Center/Dynamic/Extents/Previous/Scale/ ...] < real time>: ALL ()

<Ortho on> <Isoplane Top> <Osnap on>

Command: LINE ()

Specify next point or [Undo]: @ 0,0,0

Specify next point or [Undo]: @ 72,0,0

Specify next point or [Undo]: @ 72,104,0

Specify next point or [Undo]: @ 0,104,0

Specify next point or [Close/Undo]: C ()

Command: LINE ()

Specify next point or [Undo]: @ 0,0,0

Specify next point or [Undo]: @ 0,48,0

Department of Mechanical Engineering

Specify next point or [Undo]: @ 24,0,0
 Specify next point or [Undo]: @ 24,-16,0
 Specify next point or [Undo]: @ 24,0,0
 Specify next point or [Undo]: @ 24,-16,0
 Specify next point or [Undo]: @ 24,0,0
 Specify next point or [Undo]: @ 24,-16,0
 Specify next point or [Close/Undo]: C (□)
 Command: LINE (□)
 Specify next point or [Undo]: @ 0,0,0
 Specify next point or [Undo]: @ 72,16,0
 Specify next point or [Undo]: @ 80,0,24
 Specify next point or [Undo]: @ -80,0,0
 Specify next point or [Close/Undo]: C (□)
 Command: LINE (□)
 Specify next point or [Undo]: @ 72,32,24
 Specify next point or [Undo]: @ 80,0,24
 Specify next point or [Undo]: @ -80,0,0
 Specify next point or [Close/Undo]: C (□)
 Command: LINE (□)
 Specify next point or [Undo]: @ 0,48,0
 Specify next point or [Undo]: @ 104,0, 72
 Specify next point or [Undo]: @ -24,0, 72
 Specify next point or [Undo]: @ -24,0, 48
 Specify next point or [Undo]: @ 24,0, 0
 Specify next point or [Close/Undo]: C (□)

Command: _qsave

Command: _dimaligned

Specify first extension line origin or <select object>:

Specify second extension line origin:

Command: _dimlinear

Specify first extension line origin or <select object>:

Specify second extension line origin:

Specify dimension line location or [Mtext/Text/Angle/Horizontal/Vertical/Rotated]:

Dimension text = 48.0000

Command: _dimedit

Enter type of dimension editing [Home/New/Rotate/Oblique] <Home>: _o

Select objects: 1 found

Enter obliquing angle (press ENTER for none): 30

Command: _qsave

Department of Mechanical Engineering

Convert Isometric to Orthographic

1. Draw the (i) Front view (ii) Top View (iii) Side view of the Following Isometric Drawings using AutoCAD

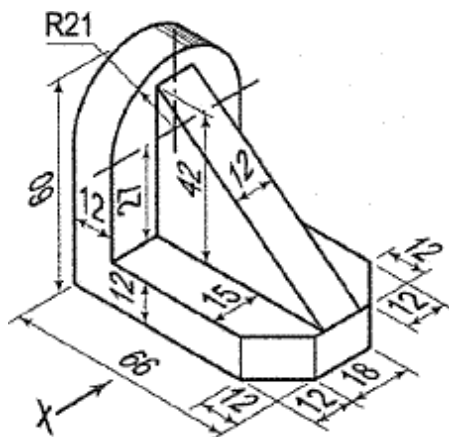
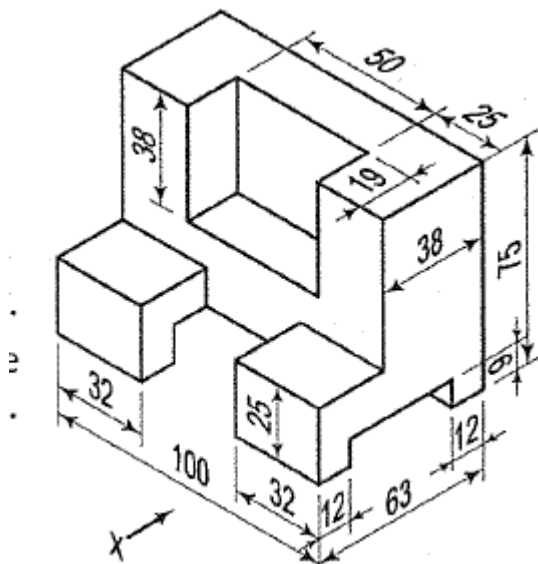
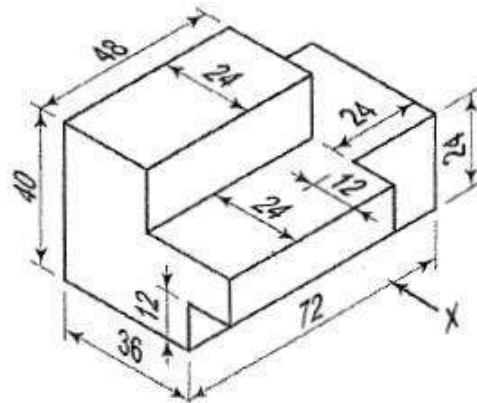
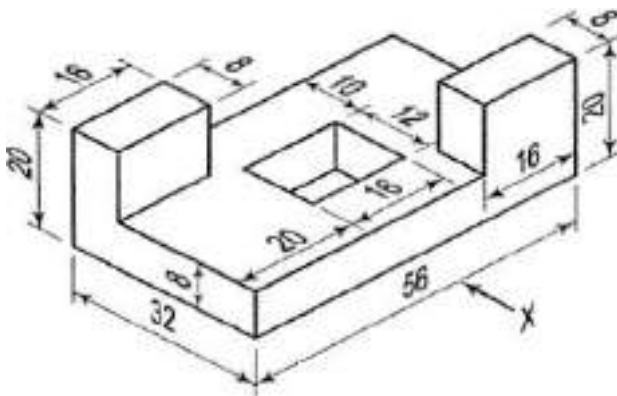
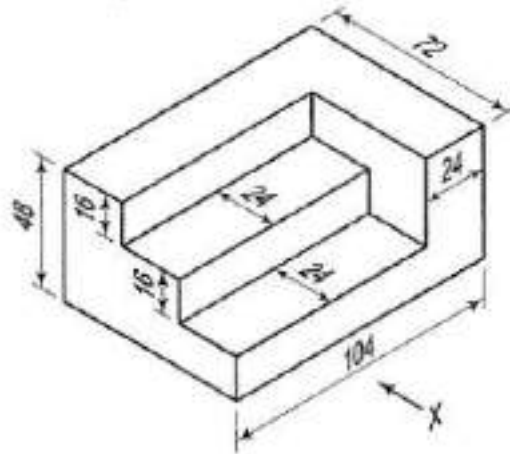
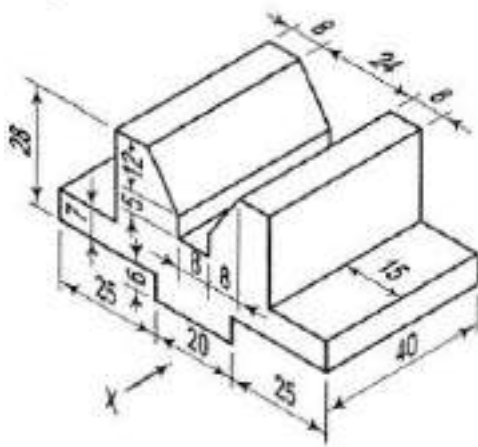

Department of Mechanical Engineering

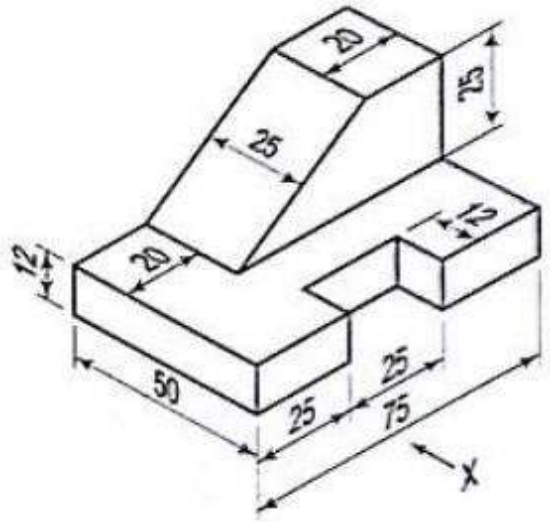
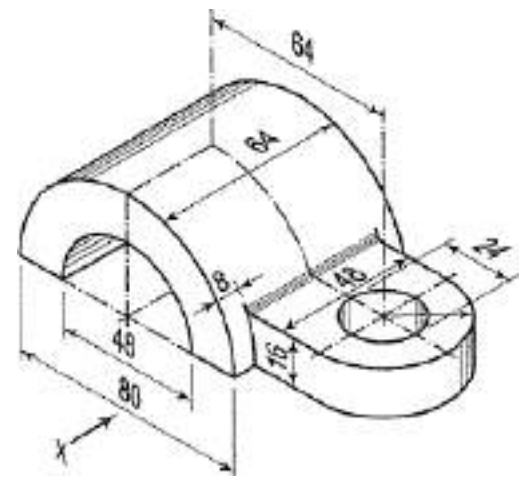
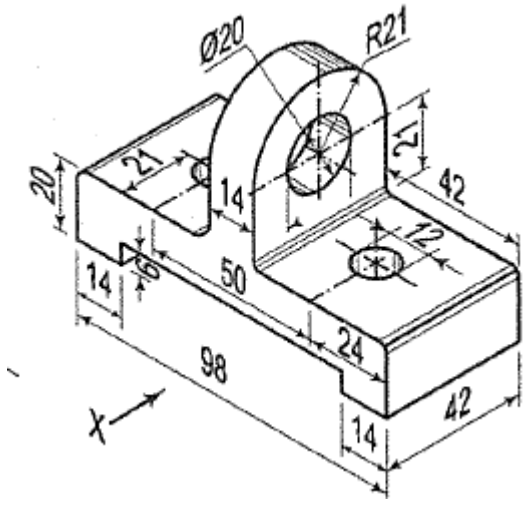

Department of Mechanical Engineering

References

1. Engineering Drawing by ND Bhatt, Charotar Publishing House Pvt. Ltd.
2. Engineering Graphics for Degree by K.C. John, PHI Learning Private Limited
3. Computer Aided Engineering Graphics by Rajashekar Patil, New Age International Pvt. Ltd.
4. Engineering Graphics with AutoCAD 2020 by James D. Bethune, Pearson Publications
5. Fundamentals of Engineering Drawing and AutoCAD by Dr. Mohd. Parvez, Galgotia Publications Pvt. Ltd.
6. Engineering Graphics Essentials with AutoCAD 2018 Instruction Text and Video Instruction. by Kirstie Plantenberg, SDC Publications.
7. <https://knowledge.autodesk.com/support/autocad-1t/learn-explore>.

[Type here]

[Type here]