

Department of Electrical & Electronics Engineering

Course File

ELECTRICAL MACHINES – II
(EE403PC)

II B.Tech II Semester

2023-24

Mr.M.Srinu



Department of Electrical & Electronics Engineering
ELECTROMAGNETIC FIELDS
Check List

S.No	Name of the Format	Page No.
1	Syllabus	1
2	Timetable	3
3	Program Educational Objectives	4
4	Program Objectives	4
5	Course Objectives	5
6	Course Outcomes	5
7	Guidelines to study the course	6
8	Course Schedule	7
9	Course Plan	10
10	Unit Plan	14
11	Lesson Plan	19
12	Assignment Sheets	41
13	Tutorial Sheets	46
14	Evaluation Strategy	51
15	Assessment in relation to COB's and CO's	53
16	Mappings of CO's and PO's	53
17	Rubric for course	55
18	Mid-I and Mid-II question papers	56
19	Mid-I mark	60
20	Mid-II mark	61
21	Sample answer scripts and Assignments	62
22	Course materials like Notes, PPT's, etc.	63

Department of Electrical & Electronics Engineering

Int. Marks:30 Ext. Marks:70 Total Marks:100

ANURAG ENGINEERING COLLEGE

(An Autonomous Institution)

III Year B.Tech. EEE -I Sem

L	T	P	C
3	0	0	3

(EE403PC) ELECTRICAL MACHINES – II

Course Objectives:

UNIT-I:

POLY-PHASE INDUCTION MACHINES: Constructional details of cage and wound rotor machines- production of a rotating magnetic field - principle of operation - rotor EMF and rotor frequency - rotor reactance, rotor current and Power factor at standstill and during operation. Rotor power input, rotor copper loss and mechanical power developed and their inter relation.

UNIT-II:

CHARACTERISTICS OF INDUCTION MACHINES: Torque equation-expressions for maximum torque and starting torque - torque slip characteristic - equivalent circuit - phasor diagram - crawling and cogging, No-load Test and Blocked rotor test –Predetermination of performance- Methods of starting and starting current and Torque calculations, Applications.

SPEED CONTROL METHODS: Change of voltage, change of frequency, voltage/frequency, injection of an EMF into rotor circuit (qualitative treatment only)-induction generator-principle of operation.

UNIT-III:

SYNCHRONOUS MACHINES: Constructional Features of round rotor and salient pole machines – Armature windings – Integral slot and fractional slot windings; Distributed and concentrated windings – distribution, pitch and winding factors – E.M.F Equation. Harmonics in generated e.m.f. – suppression of harmonics – armature reaction - leakage reactance – synchronous reactance and impedance – experimental determination - phasor diagram – load characteristics. Regulation by synchronous impedance method, M.M.F. method, Z.P.F. method and A.S.A. methods – salient pole alternators – two reaction analysis – experimental determination of X_d and X_q (Slip test) Phasor diagrams – Regulation of salient pole alternators.

UNIT-IV:

PARALLEL OPERATION OF SYNCHRONOUS MACHINES: Synchronizing alternators with infinite bus bars – synchronizing power torque – parallel operation and load sharing -Effect of change of excitation and mechanical power input. Analysis of short circuit current wave form – determination of sub-transient, transient and steady state reactance's and Applications.

SYNCHRONOUS MOTORS: Theory of operation – phasor diagram – Variation of current and

Department of Electrical & Electronics Engineering

power factor with excitation – synchronous condenser – Mathematical analysis for power developed. – Hunting and its suppression – Methods of starting – synchronous induction motor.

UNIT-V:

SINGLE PHASE MACHINES: Single phase induction motor – Constructional Features-Double revolving field theory – split-phase motors – AC series motor – Universal Motor—Shaded pole motor and Applications.

TEXT BOOKS:

1. Theory and performance of Electrical machines – J.B Gupta, S.K Kataria & Sons publishers, 2009.
2. Electric Machinery- P.S. Bimbra, Khanna Publishers, 7th edition, 2010.

REFERENCE BOOKS:

1. Electrical Machines - I.J. Nagrath & Kothari, McGraw Hill Companies, 3rd edition, 2004.
2. A Text book of Electrical Technology – B.L. Theraja and A.K. Theraja, S. Chand Publications, Vol2 eprint 2015.
3. Electrical Machines – S.K. Bhatta Charya, McGraw Hill Companies, 2007.
4. Electric Machines – M.V. Deeshpande, Wheeler Publishing, 1997.

CO-PO Mapping:

CO'S \ PO'S	PO 1	PO 2	PO 3	PO 4	PO 5	PO 6	PO 7	PO 8	PO 9	PO 10	PO 11	PO 12
CO 1	L		H		M						L	L
CO 2	L		H		M						L	L
CO 3	L		H		M						L	L
CO 4	L		H		M						L	L
CO 5	L		H		M						L	L

H-High; M-Moderate; L-Low

Department of Electrical & Electronics Engineering

Department of Electrical & Electronics Engineering**Timetable****II B.Tech. I Semester – EMF (A Sec)**

Day/Hour	9.40-10.30	10.30-11.20	11.20-12.00	12.00-12.55	12.55-1.50	1.50-2.45	2.45-3.50
Monday	EM-II						
Tuesday			EM-II				
Wednesday					EM-II		
Thursday		EM-II					
Friday						EM-II	
Saturday				EM-II			

Department of Electrical & Electronics Engineering

Vision of the Institute

To be a premier Institute in the country and region for the study of Engineering, Technology and Management by maintaining high academic standards which promotes the analytical thinking and independent judgment among the prime stakeholders, enabling them to function responsibly in the globalized society.

Mission of the Institute

To be a world-class Institute, achieving excellence in teaching, research and consultancy in cutting-edge Technologies and be in the service of society in promoting continued education in Engineering, Technology and Management.

Quality Policy

To ensure high standards in imparting professional education by providing world-class infrastructure, top-quality-faculty and decent work culture to sculpt the students into Socially Responsible Professionals through creative team-work, innovation and research

Vision of the Department

To impart technical knowledge and skills required to succeed in life, career and help society to achieve self sufficiency.

Mission of the Department

- To become an internationally leading department for higher learning.
- To build upon the culture and values of universal science and contemporary education.
- To be a center of research and education generating knowledge and technologies which lay groundwork in shaping the future in the fields of electrical and electronics engineering.
- To develop partnership with industrial, R&D and government agencies and actively participate in conferences, technical and community activities.

Department of Electrical & Electronics Engineering

Program Educational Objectives (B.Tech. – EEE)

Graduates will be able to

- PEO 1: Have a successful technical or professional career, including supportive and leadership roles on multidisciplinary teams.
- PEO 2: Acquire, use and develop skills as required for effective professional practices.
- PEO 3: Able to attain holistic education that is an essential prerequisite for being a responsible member of society.

Program Outcomes (B.Tech. – EEE)

At the end of the Program, a graduate will have the ability to

- PO 1: Apply knowledge of mathematics, science, and engineering.
- PO 2: Design and conduct experiments, as well as to analyze and interpret data.
- PO 3: Design a system, component, or process to meet desired needs within realistic constraints such as economic, environmental, social, political, ethical, health and safety, manufacturability, and sustainability.
- PO 4: Function on multi-disciplinary teams.
- PO 5: Identify, formulates, and solves engineering problems.
- PO 6: Understanding of professional and ethical responsibility.
- PO 7: Communicate effectively.
- PO 8: Broad education necessary to understand the impact of engineering solutions in a global, economic, environmental, and societal context.
- PO 9: Recognition of the need for, and an ability to engage in life-long learning.
- PO 10: Knowledge of contemporary issues.
- PO 11: Utilize experimental, statistical and computational methods and tools necessary for engineering practice.
- PO 12: Demonstrate an ability to design electrical and electronic circuits, power electronics, power systems; electrical machines analyze and interpret data and also an ability to design digital and analog systems and programming them.

Department of Electrical & Electronics Engineering

COURSE OBJECTIVES

On completion of this Subject/Course the student shall be able to:

S.No	Objectives
1	To deal with the detailed working of Three Phase induction motors
2	To analyze performance of Three Phase induction motors
3	To deal with the detailed working and voltage regulation of synchronous generators
4	To deal with the parallel operation of synchronous generators and performance of synchronous motor.
5	To deal with the operation single phase motors.

COURSE OUTCOMES

The expected outcomes of the Course/Subject are:

S.No	Outcomes
1.	Detailed working, torque equation and equivalent circuit of three phase induction motor.
2.	Performance, speed control methods and industrial applications of three phase induction motor
3.	Working of synchronous generator, voltage regulation and its phasor representation
4.	Parallel operation of synchronous generator and performance of synchronous motor.
5.	Performance and working of single phase motors

Signature of faculty

Note: Please refer to Bloom's Taxonomy, to know the illustrative verbs that can be used to state the outcomes.

Department of Electrical & Electronics Engineering

GUIDELINES TO STUDY THE COURSE / SUBJECT

Course Design and Delivery System (CDD):

- The Course syllabus is written into number of learning objectives and outcomes.
- Every student will be given an assessment plan, criteria for assessment, scheme of evaluation and grading method.
- The Learning Process will be carried out through assessments of Knowledge, Skills and Attitude by various methods and the students will be given guidance to refer to the text books, reference books, journals, etc.

The faculty be able to –

- Understand the principles of Learning
- Understand the psychology of students
- Develop instructional objectives for a given topic
- Prepare course, unit and lesson plans
- Understand different methods of teaching and learning
- Use appropriate teaching and learning aids
- Plan and deliver lectures effectively
- Provide feedback to students using various methods of Assessments and tools of Evaluation
- Act as a guide, advisor, counselor, facilitator, motivator and not just as a teacher alone

Signature of HOD

Signature of faculty

Date:

Date:

Department of Electrical & Electronics Engineering
COURSE SCHEDULE

The Schedule for the whole Course / Subject is:

S. No.	Description	Duration (Date)		Total No. of Periods
		From	To	
1.	UNIT-I: POLY-PHASE INDUCTION MACHINES: Constructional details of cage and wound rotor machines- production of a rotating magnetic field - principle of operation - rotor EMF and rotor frequency - rotor reactance, rotor current and Power factor at standstill and during operation. Rotor power input, rotor copper loss and mechanical power developed and their inter relation.	05.02.2024	20.02.2024	16
2.	UNIT-II: CHARACTERISTICS OF INDUCTION MACHINES: Torque equation-expressions for maximum torque and starting torque - torque slip characteristic - equivalent circuit - phasor diagram - crawling and cogging, No-load Test and Blocked rotor test – Predetermination of performance-Methods of starting and starting current and Torque calculations, Applications. SPEED CONTROL METHODS: Change of voltage, change of frequency, voltage/frequency, injection of an EMF into rotor circuit (qualitative treatment only)-induction generator-principle of operation.	21.02.2024	03.03.2024	12
3.	UNIT-III: SYNCHRONOUS MACHINES: Constructional Features of round rotor and salient pole machines – Armature windings – Integral slot and fractional slot windings; Distributed and concentrated windings – distribution, pitch and winding factors – E.M.F Equation. Harmonics in generated e.m.f. – suppression of harmonics – armature reaction - leakage reactance – synchronous reactance and impedance – experimental determination - phasor	4.03.2024	14.03.2024	11

Department of Electrical & Electronics Engineering

	<p>diagram – load characteristics. Regulation by synchronous impedance method, M.M.F. method, Z.P.F. method and A.S.A. methods – salient pole alternators – two reaction analysis – experimental determination of X_d and X_q (Slip test) Phasor diagrams – Regulation of salient pole alternators.</p>			
4.	<p>UNIT-IV: PARALLEL OPERATION OF SYNCHRONOUS MACHINES: Synchronizing alternators with infinite bus bars – synchronizing power torque – parallel operation and load sharing -Effect of change of excitation and mechanical power input. Analysis of short circuit current wave form – determination of sub-transient, transient and steady state reactance's and Applications. SYNCHRONOUS MOTORS: Theory of operation – phasor diagram – Variation of current and power factor with excitation – synchronous condenser – Mathematical analysis for power developed. -Hunting and its suppression – Methods of starting – synchronous induction motor.</p>	15.03.2024	321.03.2024	17
5.	<p>UNIT-V: SINGLE PHASE MACHINES: Single phase induction motor – Constructional Features-Double revolving field theory – split-phase motors – AC series motor – Universal Motor—Shaded pole motor and Applications.</p>	01.04.2024	11.04.2024	11

Total No. of Instructional periods available for the course: 73 Hours

Department of Electrical & Electronics Engineering
SCHEDULE OF INSTRUCTIONS - COURSE PLAN

Unit No.	Lesson No.	Date	No. of Periods	Topics / Sub-Topics	Objectives & Outcomes Nos.	References (Textbook, Journal)
----------	------------	------	----------------	---------------------	----------------------------	--------------------------------

Unit No.	Lesson No.	Date	No. Of Periods	Topics To Be Covered	Objectives & Outcomes Nos.	References (Textbook, Journal)
1	1	02-05-24	1	UNIT-I Three Phase Induction Motors	1 1	Electric Machinery- P.S. Bimbra
	2	02-06-24	1	Production of a rotating magnetic field	1 1	Electric Machinery- P.S. Bimbra
	3	02-07-24	1	principle of operation	1 1	Electric Machinery- P.S. Bimbra
	4	02-08-24	1	rotor emf and rotor frequency at standstill and during operation	1 1	Electric Machinery- P.S. Bimbra
	5	02-09-24	1	rotor reactance, rotor current and pf. at standstill and during operation	1 1	Electric Machinery- P.S. Bimbra
	6	02-10-24	1	Numerical problems	1 1	Electric Machinery- P.S. Bimbra
	7	02-11-24	1	relation-torque equation- deduction from torque equation	1 1	Electric Machinery- P.S. Bimbra
	8	02-12-24	11	Numerical problems	1 1	Electric Machinery- P.S. Bimbra
	9	02-13-24	1	expressions for maximum torque and starting torque	1 1	Electric Machinery- P.S. Bimbra
	10	02-14-24	1	Numerical problems	1 1	Electric Machinery- P.S. Bimbra
	11	02-15-24	1	double cage and deep bar rotors	1 1	Electric Machinery- P.S. Bimbra
	12	02-16-24	1	equivalent circuit	1 1	Electric Machinery- P.S. Bimbra
	13	02-17-24	1	phasor diagram	1 1	Electric Machinery- P.S. Bimbra

Department of Electrical & Electronics Engineering

					Bimbra
14	02-18-24	1	crawling and cogging	1 1	Electric Machinery- P.S. Bimbra
15	02-19-24	1	Numerical problems	1 1	Electric Machinery- P.S. Bimbra
16	02-20-24	1	Numerical problems	1 1	Electric Machinery- P.S. Bimbra
17	02-21-24	1	UNIT II Performance of Three Phase Induction Motors	2 2	Electric Machinery- P.S. Bimbra
18	02-22-24	1	Circle diagram-no load and blocked rotor tests	2 2	Electric Machinery- P.S. Bimbra
19	02-23-24	1	Circle diagram-no load and blocked rotor tests	2 2	Electric Machinery- P.S. Bimbra
20	02-24-24	1	Numerical problems	2 2	Electric Machinery- P.S. Bimbra
21	02-25-24	1	Numerical problems	2 2	Electric Machinery- P.S. Bimbra
22	02-26-24	1	predetermination of performance. Methods of starting, starting current and torque calculations of Induction Motors	2 2	Electric Machinery- P.S. Bimbra
23	02-27-24	1	Speed control-change of frequency	2 2	Electric Machinery- P.S. Bimbra
24	02-28-24	1	change of poles and methods of consequent poles	2 2	Electric Machinery- P.S. Bimbra
25	02-29-24	1	cascade connection, injection of an emf into rotor circuit	2 2	Electric Machinery- P.S. Bimbra
26	03-01-24	1	Applications	2 2	Electric Machinery- P.S. Bimbra
27	03-02-24	1	induction generator-principle of operation	2 2	Electric Machinery- P.S. Bimbra
28	03-03-24	1	Numerical problems	2 2	Electric Machinery- P.S.

2

Department of Electrical & Electronics Engineering

						Bimbra
3	29	03-04-24	1	UNIT III Synchronous Generator Armature windings	3 3	Electric Machinery- P.S. Bimbra
	30	03-05-24	1	Integral slot windings	3	Electric Machinery- P.S. Bimbra
	31	03-06-24	1	fractional slot windings	3	Electric Machinery- P.S. Bimbra
	32	03-07-24	1	Distributed and concentrated windings	3	Electric Machinery- P.S. Bimbra
	33	03-08-24	1	distribution, pitch and winding factors	3	Electric Machinery- P.S. Bimbra
	34	03-09-24	1	E.M.F Equation	3	Electric Machinery- P.S. Bimbra
	35	03-10-24	1	leakage reactance	3	Electric Machinery- P.S. Bimbra
	36	03-11-24	1	synchronous reactance and impedance	3	Electric Machinery- P.S. Bimbra
	37	03-12-24	1	experimental determination	3	Electric Machinery- P.S. Bimbra
	38	03-13-24	1	phasor diagram	3	Electric Machinery- P.S. Bimbra
	39	03-14-24	1	load characteristics	3	Electric Machinery- P.S. Bimbra
	40	03-15-24	1	UNIT IV Voltage Regulation of Synchronous Generators 1Regulation by synchronous impedance method	3	Electric Machinery- P.S. Bimbra
	41	03-16-24	1	Numerical problems	4 4	Electric Machinery- P.S. Bimbra
42	03-17-24	1	M.M.F. method	4 4	Electric Machinery- P.S. Bimbra	
43	03-18-24	1	Numerical problems	4 4	Electric Machinery- P.S.	

Department of Electrical & Electronics Engineering

4					Bimbra	
	44	03-19-24	1	Z.P.F. method	4 4	Electric Machinery- P.S. Bimbra
	45	03-20-24	1	A.S.A. methods	4 4	Electric Machinery- P.S. Bimbra
	46	03-21-24	1	Numerical problems	4 4	Electric Machinery- P.S. Bimbra
	47	03-22-24	1	Salient pole alternators	4 4	Electric Machinery- P.S. Bimbra
	48	03-23-24	1	two reaction theory	4 4	Electric Machinery- P.S. Bimbra
	49	03-24-24	1	Regulation of salient pole alternators	4	Electric Machinery- P.S. Bimbra
	50	03-25-24	1	experimental determination of X_d and X_q (Slip test) Phasor diagrams	4 4	Electric Machinery- P.S. Bimbra
	51	03-26-24	1	Parallel Operation of Synchronous Generator Synchronizing alternators with infinite bus bars	4 4	Electric Machinery- P.S. Bimbra
	52	03-27-24	1	Synchronizing power and synchronizing torque	4 4	Electric Machinery- P.S. Bimbra
	53	03-28-24	1	parallel operation and load sharing	4 4	Electric Machinery- P.S. Bimbra
	54	03-29-24	1	Effect of change of excitation and mechanical power input	4 4	Electric Machinery- P.S. Bimbra
	55	03-30-24	1	Numerical problems	4 4	Electric Machinery- P.S. Bimbra
	56	03-31-24	1	Numerical problems	4 4	Electric Machinery- P.S. Bimbra
57	04-01-24	1	UNIT V Synchronous Motors Principle of operation-methods of starting-phasor diagram	5 5	Electric Machinery- P.S. Bimbra	
58	04-02-24	1	Variation of current and power factor with excitation-synchronous condenser-	5 5	Electric Machinery- P.S. Bimbra	

Department of Electrical & Electronics Engineering

5	59	04-03-24	1	Mathematical analysis for power developed	5 5	Electric Machinery- P.S. Bimbra
	60	04-04-24	1	circle diagrams of synchronous machines	5 5	Electric Machinery- P.S. Bimbra
	61	04-05-24	1	hunting and its suppression	5 5	Electric Machinery- P.S. Bimbra
	62	04-06-24	1	damper windings- Applications.	5 5	Electric Machinery- P.S. Bimbra
	63	04-07-24	1	Single Phase Motors: Types- capacitor start	5 5	Electric Machinery- P.S. Bimbra
	64	04-08-24	1	capacitor run	5 5	Electric Machinery- P.S. Bimbra
	65	04-09-24	1	split phase motor	5 5	Electric Machinery- P.S. Bimbra
	66	04-10-24	1	shaded pole motor-universal motor	5 5	Electric Machinery- P.S. Bimbra
	67	04-11-24	1	Applications	5 5	Electric Machinery- P.S. Bimbra

Signature of HOD

Signature of faculty

Date:

Date:

Note:

1. Ensure that all topics specified in the course are mentioned.
2. Additional topics covered, if any, may also be specified in bold.
3. Mention the corresponding course objective and outcome numbers against each topic.

Refer assignment – I & tutorial-I sheets

Signature of faculty

Department of Electrical & Electronics Engineering

Department of Electrical & Electronics Engineering

Unit No.	Lesson No.	Date	Day Of The Week	Topics To Be Covered
1	1	02-05-24	FRI	UNIT-I Three Phase Induction Motors
	2	02-06-24	SAT	Production of a rotating magnetic field
	3	02-07-24	MON	principle of operation
	4	02-08-24	TUE	rotor emf and rotor frequency at standstill and during operation
	5	02-09-24	THU	rotor reactance, rotor current and pf. at standstill and during operation
	6	02-10-24	FRI	Numarical problems
	7	02-11-24	THU	relation-torque equation-deduction from torque equation
	8	02-12-24	FRI	Numarical problems
	9	02-13-24	SAT	expressions for maximum torque and starting torque
	10	02-14-24	MON	Numarical problems
	11	02-15-24	TUE	double cage and deep bar rotors
	12	02-16-24	THU	equivalent circuit
	13	02-17-24	FRI	phasor diagram
	14	02-18-24	SAT	crawling and cogging.
	15	02-19-24	MON	Numarical problems
	16	02-20-24	TUE	Numarical problems
2	17	02-21-24	THU	UNIT II Performance of Three Phase Induction Motors
	18	02-22-24	FRI	Circle diagram-no load and blocked rotor tests
	19	02-23-24	SAT	Circle diagram-no load and blocked rotor tests
	20	02-24-24	MON	Numarical problems
	21	02-25-24	TUE	Numarical problems
	22	02-26-24	FRI	predetermination of performance. Methods of starting, starting current and torque calculations of Induction Motors
	23	02-27-24	MON	Speed control-change of frequency

Department of Electrical & Electronics Engineering

	24	02-28-24	TUE	change of poles and methods of consequent poles
	25	02-29-24	THU	cascade connection, injection of an emf into rotor circuit
	26	03-01-24	FRI	Applications
	27	03-02-24	SAT	induction generator-principle of operation
	28	03-03-24	TUE	Numarical problems
3	29	03-04-24	THU	UNIT III Synchronous Generator Armature windings
	30	03-05-24	FRI	Integral slot windings
	31	03-06-24	SAT	fractional slot windings
	32	03-07-24	MON	Distributed and concentrated windings
	33	03-08-24	TUE	distribution, pitch and winding factors
	34	03-09-24	FRI	E.M.F Equation
	35	03-10-24	TUE	leakage reactance
	36	03-11-24	THU	synchronous reactance and impedance
	37	03-12-24	FRI	experimental determination
	38	03-13-24	MON	phasor diagram
	39	03-14-24	TUE	load characteristics
4	40	03-15-24	THU	UNIT IV Voltage Regulation of Synchronous Generators Regulation by synchronous impedance method
	41	03-16-24	FRI	Numarical problems
	42	03-17-24	SAT	M.M.F. method
	43	03-18-24	MON	Numarical problems
	44	03-19-24	TUE	Z.P.F. method
	45	03-20-24	THU	A.S.A. methods
	46	03-21-24	FRI	Numarical problems
	47	03-22-24	SAT	Salient pole alternators
	48	03-23-24	MON	two reaction theory

Department of Electrical & Electronics Engineering

5	49	03-24-24	TUE	Regulation of salient pole alternators
	50	03-25-24	THU	experimental determination of X_d and X_q (Slip test) Phasor diagrams
	51	03-26-24	FRI	Parallel Operation of Synchronous Generator Synchronizing alternators with infinite bus bars
	52	03-27-24	MON	Synchronizing power and synchronizing torque
	53	03-28-24	TUE	parallel operation and load sharing
	54	03-29-24	THU	Effect of change of excitation and mechanical power input
	55	03-30-24	FRI	Numarical problems
	56	03-31-24	SAT	Numarical problems
	57	04-01-24	MON	UNIT V Synchronous Motors Principle of operation-methods of starting-phasor diagram
	58	04-02-24	TUE	Variation of current and power factor with excitation-synchronous condenser-
	59	04-03-24	THU	Mathematical analysis for power developed
	60	04-04-24	FRI	circle diagrams of synchronous machines
	61	04-05-24	SAT	hunting and its suppression
	62	04-06-24	TUE	damper windings-Applications.
63	04-07-24	THU	Single Phase Motors: Types-capacitor start	
64	04-08-24	FRI	capacitor run	
65	04-09-24	SAT	split phase motor	
66	04-10-24	MON	shaded pole motor-universal motor	
67	04-11-24	TUE	Applications	

Signature of faculty

Department of Electrical & Electronics Engineering

ASSIGNMENT – 1

This Assignment corresponds to Unit No. 1

Question No.	Question	Objective No.	Outcome No.
1	<p>A 440 V, 3 phase, 8 pole, 50 Hz, 40 kW, star connected three induction motor has the following parameters:</p> <p>Stator resistance = 0.1 Ω, stator reactance = 0.4 Ω</p> <p>Equivalent rotor resistance referred to stator = 0.1552 Ω</p> <p>Equivalent rotor reactance referred to stator = 0.44 Ω</p> <p>The stator core loss is 1250 W while mechanical loss is 1000 W.</p> <p>It draws a no load current of 20 A at a p.f. of 0.09 lagging.</p> <p>While running at a speed of 727.5 r.p.m. Calculate,</p> <p>i) Input line current and p.f.</p> <p>ii) Torque developed</p> <p>iii) Output power and</p> <p>iv) Efficiency.</p>	1	1
2	<p>A 12 pole, 50 Hz, 3-phase induction motor has rotor resistance of 0.1552 Ω and standstill reactance of 0.252 Ω per phase. On full load it is running at a speed of 480 r.p.m. The rotor induced e.m.f. per phase at standstill is observed to be 32 V.</p> <p>Calculate :</p> <p>i) starting torque,</p> <p>ii) full load torque,</p> <p>iii) maximum torque</p> <p>iv) speed at maximum torque.</p>	1	1

Department of Electrical & Electronics Engineering

Signature of HOD

Signature of faculty

Date:

Date:

Department of Electrical & Electronics Engineering

ASSIGNMENT – 2

This Assignment corresponds to Unit No. 2

Question No.	Question	Objective No.	Outcome No.
1	<p>A 4 kW, 400 V, 3-phase, delta connected slip ring induction motor gave the following test results.</p> <p>Blocked rotor test : 210 V, 16 A, Power factor = 0.45</p> <p>No load test : 400 V, 3.3 A, power factor = 0.174</p> <p>Draw circle diagram and find maximum torque and corresponding efficiency and line current. At stand still rotor and stator resistances are equal</p>	2	2
2	<p>1. A 4 pole, 3 phase, 50 Hz slip ring type induction motor has a rotor resistance of 0.25Ω per phase and rotor reactance of 2Ω per phase at standstill condition. It is running at 1455 r.p.m. speed. Calculate the value of external resistance per phase required in the rotor circuit to reduce the speed by 17%. Assume load torque constant</p>	2	2
3	<p>Derive an expression for the torque of an induction motor and obtain the condition for maximum torque.</p>	2	2

Signature of HOD

Signature of faculty

Date:

Date:

Department of Electrical & Electronics Engineering

ASSIGNMENT – 3

This Assignment corresponds to Unit No. 3

Question No.	Question	Objective No.	Outcome No.
1	The following data are ,for a 3-phase slip-ring induction motor, Maximum starting current = Full-load current Full load slip = 3% Rotor resistance per phase = 0.025 ohm Calculate the steps in a 5-step rotor resistance starter.	3	3
2	Explain the speed control of three phase induction motor using cascaded connection.	3	3
3	A single phase 1500 r.p.m., 4 pole alternator has 8 conductors per slot with total of 24 slots. The winding is short pitched by 1/6 th of full pitch. Assume distributed winding with flux per pole as 0.05 Wb. Calculate the induced e.m.f.		

Signature of HOD

Signature of faculty

Date:

Date:

Department of Electrical & Electronics Engineering
ASSIGNMENT – 4

This Assignment corresponds to Unit No. 4

Question No.	Question	Objective No.	Outcome No.
1	A 3 phase, 16 pole, star connected alternator has 144 slots on the armature periphery. Each slot contains 10 conductors. It is driven at 375 r.p.m. The line value of em.f. available across the terminals is observed to be 2.657 kV. Find the frequency of the induced e.m.f. and flux per pole.	4	4
2	A 230 V, 3-phase, star connected alternator gives on open circuit, e.m.f. of 230 V, for a field current of 0.38 A. The same field current on short circuit causes an armature current of 12.5 A. The armature resistance measured between two lines 1.8 ohms. Find the regulation for the current of 10 amps at 0.8 lagging and 0.8 leading power factors.	4	4
3	Why parallel connection of alternator is necessary ? What are the advantages of connecting alternators in parallel?	4	4

Signature of HOD

Signature of faculty

Date:

Date:

Department of Electrical & Electronics Engineering
ASSIGNMENT – 5

This Assignment corresponds to Unit No. 5

Question No.	Question							Objective No.	Outcome No.
1	The open circuit and short circuit test results for 3 ϕ . star connected, 1000 kVA, 1905 V, 50 Hz alternator are							4	4
	Open circuit terminal voltage (Voc)line V	7 6 0	1 5 0	1 7 0	1 9 5	2 3 0	2 6 0		
	Short circuit current I _{sc} A	- -	2 2 0	-- - -	3 3 5	-- - -	-- - -		
	Field current I _f , A	1 0	2 0	2 5	3 0	4 0	5 0		
The armature reactance per phase is 0.2 Ω . Draw the open circuit and short circuit characteristics and find the regulation on full load 0.8 lagging p.f. by. i) ampere-turn method and ii) synchronous impedance method.									
2	What is synchronous condenser? Explain with the help of phaser diagram							4	4
3	Explain the constructional details and principle of operation of a Capacitor start induction motor and capacitor start capacitor run induction motor.							4	4

Signature of HOD

Signature of faculty

Course File



Department of Electrical & Electronics Engineering

Date:

Date:

Department of Electrical & Electronics Engineering**TUTORIAL – 1**

This tutorial corresponds to Unit No. 1 (Objective Nos.: 1, Outcome Nos.: 1)

Q1. A three-phase slip ring induction motor is fed from the rotor side with the stator winding short-circuited. The frequency of the current flowing in the short-circuited stator is _____

- a) Slip frequency
- b) Supply frequency
- c) The frequency corresponding to rotor speed
- d) Zero

Q2. . An 8-pole, 3-phase, 50 Hz induction motor is operating at a speed of 720 rpm. The frequency of the rotor current of the motor in Hz is _____

- a) 2
- b) 4
- c) 3
- d) 1

Q3. A 50 Hz, 4poles, a single phase induction motor is rotating in the clockwise direction at a speed of 1425 rpm. The slip of motor in the direction of rotation & opposite direction of the motor will be respectively.

- a) 0.05, 0.95
- b) 0.04, 1.96
- c) 0.05, 1.95
- d) 0.05, 0.02

Q4. The frame of an induction motor is made of _____

- a) Aluminum
- b) Silicon steel
- c) Cast iron
- d) Stainless steel

Signature of HOD

Signature of faculty

Date:

Date:

Department of Electrical & Electronics Engineering**TUTORIAL – 2**

This tutorial corresponds to Unit No. 2 (Objective Nos.: 2, Outcome Nos.: 2)

Q1. A 10 kW, 400 V, 3-phase, 4-pole, 50 Hz induction motor develops the rated output at rated voltage with its slip rings shorted. The maximum torque equal to twice the full load torque occurs at the slip of 10% with zero external resistance in the rotor circuit. The slip at the full load torque will be?

- a) 2.7%
- b) 5%
- c) 3.7%
- d) 10%

Q2. A 10 kW, 400 V, 3-phase, 4-pole, 50 Hz induction motor develops the rated output at rated voltage with its slip rings shorted. The maximum torque is twice the full load torque occurs at the slip of 10% with zero external resistance in the rotor circuit. The speed at the full load torque will be?

- a) 1460 rpm
- b) 1400 rpm
- c) 1360 rpm
- d) 1470 rpm

Q3. A 10 kW, 400 V, 3-phase, 4-pole, 50 Hz induction motor develops the rated output at rated voltage with its slip rings shorted. The maximum torque is twice the full load torque occurs at the slip of 10% with zero external resistance in the rotor circuit. An external resistance is now tripled in the rotor circuit. Then the stator current will _____

- a) remain constant
- b) increase
- c) decrease
- d) any of the mentioned

Signature of HOD

Signature of faculty

Date:

Date:

Department of Electrical & Electronics Engineering

TUTORIAL SHEET – 3

This tutorial corresponds to Unit No. 3 (Objective Nos.: 3, Outcome Nos.: 3)

Q1 . How many categories can the synchronous motors be divided into?

- a) 4
- b) 3
- c) 5
- d) 2

Q2 How is the turbo-alternators driven by?

- a) water turbines
- b) steam turbines
- c) engine driven generators
- d) compensators

Q3. What is the speed of the turbo-alternators?

- a) 100-1000 rpm
- b) 5000 rpm
- c) 1500 rpm
- d) 3000 rpm

Signature of HOD

Signature of faculty

Date:

Date:

Department of Electrical & Electronics Engineering

TUTORIAL – 4

This tutorial corresponds to Unit No. 4 (Objective Nos.: 3, Outcome Nos.: 3)

Q1. If a 3 phase alternator is short circuited at its terminal, then the initial value of short circuit current will be limited by

- a. Synchronous reactance
- b. Transient reactance
- c. Sub transient reactance
- d. All of the above

Q2. The change in excitation of the two alternators operating in parallel causes

- a. Only the kVAR sharing of two alternators without disturbing kW sharing of the two machines
- b. Only the kW sharing of two alternators without disturbing kVAR sharing of the two machines
- c. Both the kVAR sharing and kW sharing of two alternators
- d. None of the above

Q3. The increase in mechanical torque in case of alternator will

- a. Increase the armature current and reduce the power factor
- b. Increase the armature current and improve the power factor
- c. Decrease the armature current and improve the power factor
- d. Decrease the armature current and reduce the power factor

Signature of HOD

Signature of faculty

Date:

Date:

Department of Electrical & Electronics Engineering

TUTORIAL SHEET – 5

This tutorial corresponds to Unit No. 5 (Objective Nos.: 5, Outcome Nos.: 5)

Q1. Which of the following circuit is designed to dissipate heat produced in the machine?

- a) Electric circuit
- b) Magnetic circuit
- c) Dielectric circuit
- d) Thermal circuit

Q2. Which of the following materials is generally used in the design of electromagnetic machines?

- a) Paramagnetic materials
- b) Diamagnetic materials
- c) Ferromagnetic materials
- d) Core-magnetic materials

Q3. Which of the following kind of conductors will require thicker insulation?

- a) Large sized conductor
- b) Small-sized conductor
- c) Conductors with high permeance
- d) Conductors with low permeance

Signature of HOD

Signature of faculty

Date:

Date:

Department of Electrical & Electronics Engineering

EVALUATION STRATEGY

Target (s)

- a. Percentage of Pass : 95%

Assessment Method (s) (Maximum Marks for evaluation are defined in the Academic Regulations)

- a. Daily Attendance
- b. Assignments
- c. Online Quiz (or) Seminars
- d. Continuous Internal Assessment
- e. Semester / End Examination

List out any new topic(s) or any innovation you would like to introduce in teaching the subjects in this semester

Case Study of any one existing application

Signature of HOD

Signature of faculty

Date:

Date:

Department of Electrical & Electronics Engineering**COURSE COMPLETION STATUS**

Actual Date of Completion & Remarks if any

Units	Remarks	Objective No. Achieved	Outcome No. Achieved
Unit 1	completed on 20.02.2024	1	1
Unit 2	completed on 03.03.2024	2	2
Unit 3	completed on 14.03.2024	3	3
Unit 4	completed on 31.03.2024	4	4
Unit 5	completed on 11.04.2024	5	5

Signature of HOD

Signature of faculty

Date:

Date:

Department of Electrical & Electronics Engineering

Mappings

1. Course Objectives-Course Outcomes Relationship Matrix

(Indicate the relationships by mark "X")

Course-Objectives \ Course-Outcomes	1	2	3	4	5
1	H		M		
2		H			
3			H		
4				H	
5					H

2. Course Outcomes-Program Outcomes (POs) & PSOs Relationship Matrix

(Indicate the relationships by mark "X")

C-Outcomes \ P-Outcomes	a	b	c	d	e	f	g	h	i	j	k	l	PSO 1	PSO 2
1	H			M									H	
2		M	H			M							H	H
3					H				M		M			M
4						M	H						M	
5										H				

Department of Electrical & Electronics Engineering

Rubric for Evaluation

Performance Criteria	Unsatisfactory	Developing	Satisfactory	Exemplary
	1	2	3	4
<i>Research & Gather Information</i>	Does not collect any information that relates to the topic	Collects very little information some relates to the topic	Collects some basic Information most relates to the topic	Collects a great deal of Information all relates to the topic
<i>Fulfill team role's duty</i>	Does not perform any duties of assigned team role.	Performs very little duties.	Performs nearly all duties.	Performs all duties of assigned team role.
<i>Share Equally</i>	Always relies on others to do the work.	Rarely does the assigned work - often needs reminding.	Usually does the assigned work - rarely needs reminding.	Always does the assigned work without having to be reminded
<i>Listen to other team mates</i>	Is always talking— never allows anyone else to speak.	Usually doing most of the talking-- rarely allows others to speak	Listens, but sometimes talks too much.	Listens and speaks a fair amount.

II B.TECH IV SEMESTER II MID EXAMINATIONS - JUNE 2024

Branch : B.Tech. (EEE)

Max. Marks : 30M

Date : 19-Jun-2024 Session : Morning

Time : 120 Min

Subject : Electrical Machines-II,EE403PC

PART - A

ANSWER ALL THE QUESTIONS

10 X 1M = 10M

Q.No	Question		CO	BTL
1.	Armature reaction in an alternator primarily affects (A). rotor speed (B). terminal voltage per phase (C). frequency of armature current (D). generated voltage per phase.	()	CO3	3
2.	The frequency of voltage generated by an alternator having 4-poles and rotating at 1800 r.p.m. is ----- hertz. (A). 60 (B). 70 (C). 120 (D). 45	()	CO3	3
3.	The V-curves of a synchronous motor show relationship between (A). field current and armature current (B). excitation current and back e.m.f (C). field current and supply voltage (D). armature current and supply voltage.	()	CO4	3
4.	For a machine on infinite bus active power can be varied by (A). changing field excitation (B). changing of prime mover speed (C). both (a) and (b) above (D). none of the above	()	CO4	2
5.	It is never advisable to connect a stationary alternator to live bus-bars because it (A). is likely to run as synchronous motor (B). will get short-circuited (C). will decrease bus- bar voltage though momentarily (D). will disturb generated e.m.fs. of other alternators connected in parallel	()	CO4	1
6.	Keeping its excitation constant, if steam supply of an alternator running in parallel with another identical alternator is increased, then (A). it would over-run the other alternator (B). its rotor will fall back in phase with respect to the other machine (C). it will supply greater portion of the load (D). its power factor would be decreased.	()	CO4	1
7.	Speed control of a universal motor is achieved by ? (A). varying field flux with tapped field windings (B). applying variable voltage by means of variable auto-transformer (C). connecting rheostat in series (D). all of the above methods	()	CO5	1
8.	A universal motor operates on ? (A). synchronous speed with varying load (B). constant load and varying speed (C). approximately constant speed and load (D). constant speed and varying load	()	CO5	1
9.	Which of the following applications make use of a universal motor (A). Portable tools (B). Lathe machines (C). Oil expeller (D). Floor polishing machine	()	CO5	2
10.	In a shaded pole motor, the direction of rotation is from ? (A). shaded pole to main pole (B). main pole to shaded pole (C). depends on supply line polarity (D). none of the above	()	CO5	2

PART - B

ANSWER ANY FOUR

4 X 5M = 20M

Q.No	Question		CO	BTL
11.	Explain the procedure of experimental determination of X_d and X_q (Slip test).		CO3	3

12.	Explain the procedure of drawing graph for MMF method.	CO3	2
13.	Explain the power stages in synchronous motor including losses.	CO4	1
14.	Derive the synchronising power of an alternators connected in parallel to the infinite bus.	CO4	3
15.	Explain the constructional features and principle of operation of shaded pole motor.	CO5	2
16.	Give the applications of split phase motor, A.C series motor, universal motor and shaded pole motor.	CO5	1

Continuous Internal Assessment (R-22)

Programme: **BTech**

Year: **II**

Course: **Theory**

A.Y: **2023-24**

Course: **ELECTRICAL MACHINS**

Section:

Faculty Name: **S CHANDRASHEKAR**

S. No	Roll No	MID-I (35M)	MID-II (35M)	Avg. of MID I & II	Viva-Voce/Poster Presentation (5M)	Total Marks (40)
1	22C11A0201	25	22	24	5	29
2	22C11A0202	19	25	22	5	27
3	22C11A0203	22	22	22	5	27
4	22C11A0204	26	20	23	5	28
5	22C11A0205	18	13	16	5	21
6	22C11A0206	30	23	27	5	32
7	22C11A0207	25	30	28	5	33
8	22C11A0208	23	27	25	5	30
9	23C15A0201	29	22	26	5	31
10	23C15A0202	14	21	18	5	23
11	23C15A0203	25	22	24	5	29
12	23C15A0204	29	26	28	5	33
13	23C15A0205	27	26	27	5	32
14	23C15A0206	32	29	31	5	36
15	23C15A0207	32	30	31	5	36
16	23C15A0208	24	22	23	5	28
17	23C15A0209	27	31	29	5	34
18	23C15A0210	30	28	29	5	34
19	23C15A0211	26	24	25	5	30
20	23C15A0212	33	30	32	5	37
21	23C15A0213	28	26	27	5	32

No. of Absentees: 00

Total Strength: 21

Signature of Faculty

:

Signature of HoD



ANURAG ENGINEERING COLLEGE

(Approved by AICTE, New Delhi, (An Autonomous Institution)
(Affiliated to JNTUH, Hyderabad, Accredited by NAAC with A+ Grade)
Ananthagiri (V & M), Kodad, Suryapet (Dist), Telangana.

Program			YEAR	SEMESTER	MID EXAMINATION									
B.Tech.	M.Tech.	M.B.A.	II	II	Mid-2									
HALL TICKET NO.														
2	3	0	1	5	A	0	9	0	1					
Course: FM-II						Regulation: R99		Branch or Specialization: EFE						
Q.No. and Marks Awarded						Signature of Student: S. Abhiresh		Signature of invigilator with date: R. S. 19/11/24						
1	2	3	4	5	6	7	8	9	10	11	Signature of the Evaluator: S. S.			
											Maximum Marks	30	Marks Obtained	17

(Start Writing From Here)

Part-A.

- 1. ~~D~~
- 2. ~~A~~
- 3. ~~A~~
- 4. ~~B~~
- 5. ~~D~~
- 6. ~~D~~
- 7. ~~A~~
- 8. ~~B~~
- 9. ~~D~~
- 10. ~~B~~

Part-B.

16. i) Applications of split phase motor.

- * It is used in home appliance.
- * It is used in portable tools.

- * Belts
- * Blowers.

Applications of A.C series motor.

- * It is used in converse.

* And it is used in many home appliances.

* Trolley cars.

iii) Universal motor.

* It is used in grinders & blenders.

* Trimmers.

* Blowers & vacuum cleaners.

* Conveyer belts.

* And kitchen appliances & polishing machines.

iv) Shaded pole motor.

* Portable tools.

* Fans

* Coolers

* Trolley cars etc...

15. Shaded pole motor.

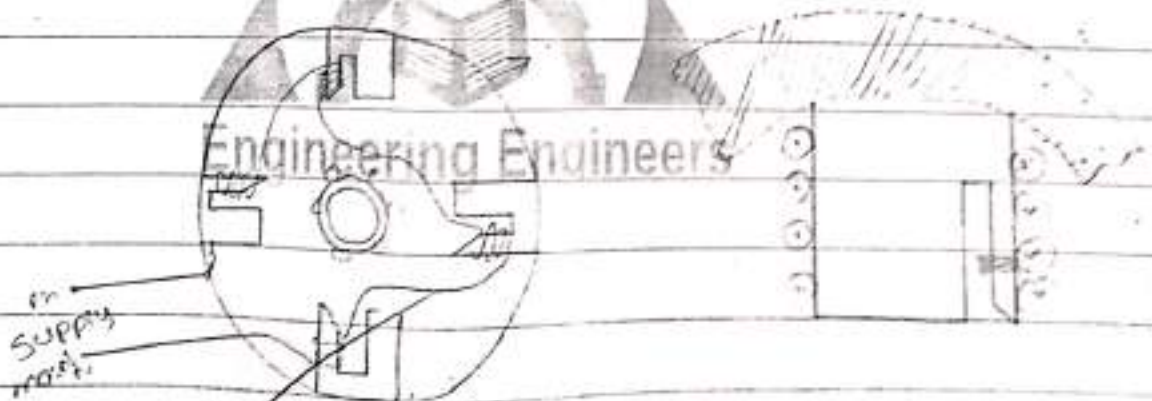

* Construction:

* The above fig shows the shaded pole motor.

* The 1/3rd of the pole is shaded the magnetic flux can't link the non shaded pole when the supply is on.

* The stator of the motor is salient pole and

rotation

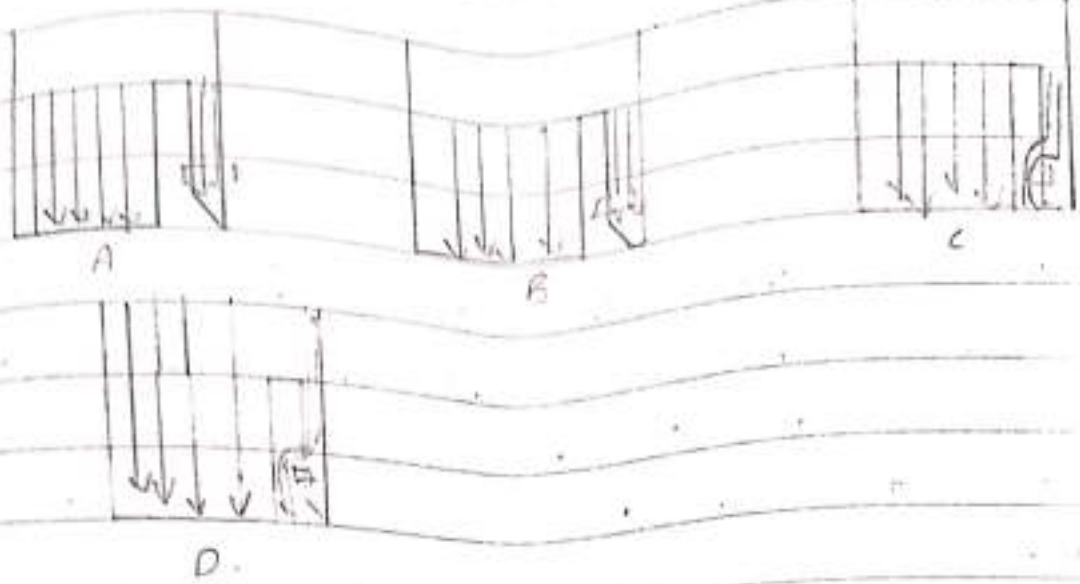

- * The above fig shows the flux passing through the poles.
- * The flux passing through shaded pole is not uniform and it cross magnetising.
- * When the supply is on the emf is produced in the stator rotor. These rotor winding links with stator winding the emf is induced.
- * The non-shaded part can't link with flux to shaded part. By shading the pole the flux produces more and emf induced is more.

Applications:

- * It is used in small applications like Blowers.
- * Mixers.
- * Polishing machines.
- * Vacuum cleaners.

Q2 * The current passing through a conductor the emf is induced in it. These emf are induced in lagging & leading unity.

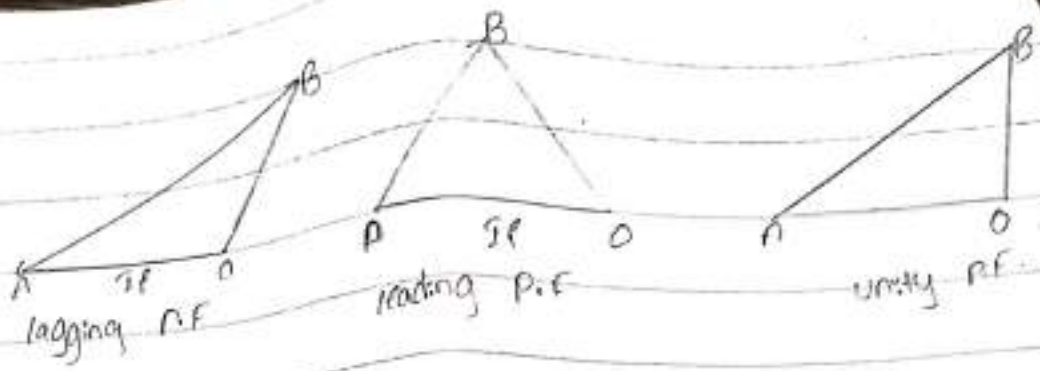

- * In case one the lagging P.F produces If field current these If lags the OA, is 90° .
- * In case 2 the If lags by OB_2 is $90^\circ - \theta$ and the OA_2 lags with If is unity P.F.
- * we can determine the value of mmf by using o.c.c & s.c.c test.

Graph:

* The resistance & reactance r_i is negligible because it is so small.

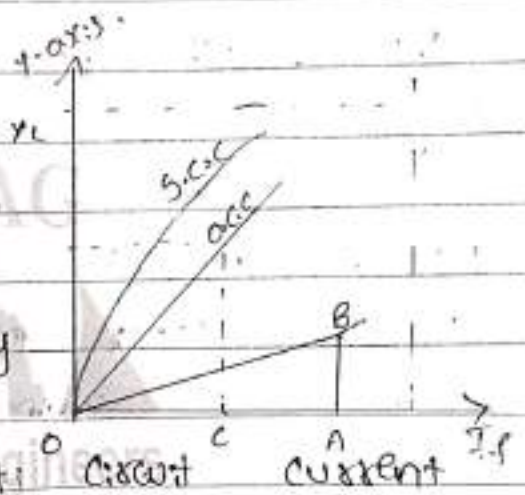

* The OA is the supply normal current.

* And OC is the short circuit current of the motor. By using o.c.c & s.c.c test we can determine If, Ia & Ra.

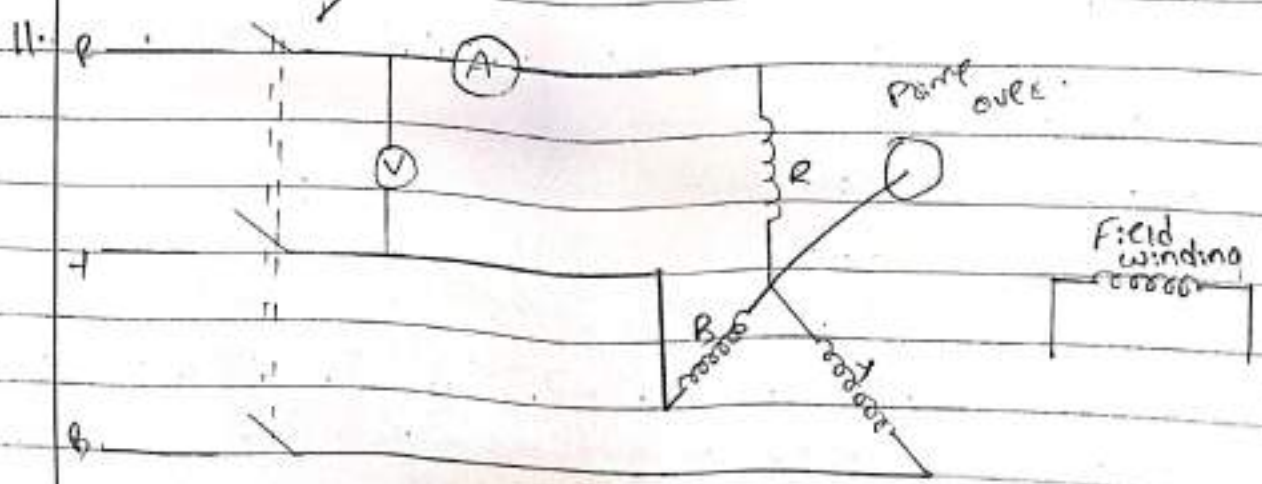

* The d -axis is determined by o.c.c and s.c.c test and q -axis is determined by slip test.

* In slip test we can the values of x_d & x_q .

* The external prime over is connected to the supply mains. The prime over, make the speed of prime over to rotor speed.

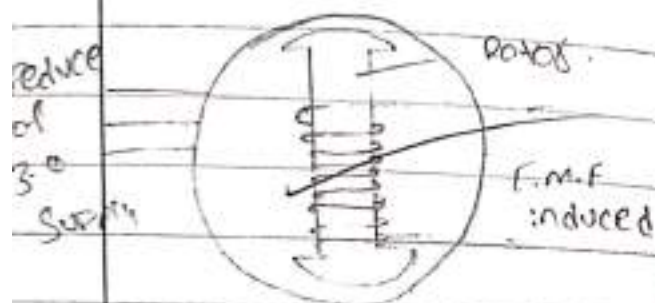

* And make's the prime over is open and switch of the supply, when the

supply is on the current flowing through a conductor the flux is induced in it. These flux links with the coil and the rotates in the armature.

* From that we can determine the x_d & x_q values from the slip test.



ANURAG ENGINEERING COLLEGE

(Approved by AICTE, New Delhi, (An Autonomous Institution)
Affiliated to JNTUH, Hyderabad, Accredited by NAAC with A+ Grade)
Ananthagiri (V & M), Kodad, Suryapet (Dist), Telangana.

Program										
B.Tech.			M.Tech.				M.B.A.			
HALL TICKET NO.										
2	3	0	1	5	A	0	2	1	0	
Course: Electrical Machines-II										
Q.No. and Marks Awarded										
1	2	3	4	5	6	7	8	9	10	11

YEAR	SEMESTER	MID EXAMINATION
II	II	II
Regulation : 22	Branch or Specialization: EEE	
Signature of Student: B. Rajeshwari.		
Signature of invigilator with date: 19/6/24		
Signature of the Evaluator:		
Maximum Marks	30	Marks Obtained
		23

(Start Writing From Here)

PART-A

1. D

2. A

3. A

4. B

5. B

6. B

7. C

8. D

9. A



16. Applications:

⇒ A.C series motor: Because of high starting torque the motor used in

- * Electric traction
- * Locomotives
- * Hoists etc...

⇒ Split phase motor:

- * Fans
- * Blowers
- * Office appliances
- * Low inertia loads etc...

⇒ shaded pole motor: Because of low starting torque the motor used in

- * Fans
- * toys
- * vacuum cleaner
- * washing machines
- * Hair dryers etc...

⇒ Universal motor:

- * Kitchen appliances
- * Table fans
- * Hair dryers
- * Grinders
- * Polisher etc...

shaded pole motor:

In this motor, the mostly commonly used is squirrel cage rotor and the winding are wound on the poles and it is also connected to the supply mains. In this we are placed shading coil which is short circuited with copper wires is known as shading coil (or) copper coil.

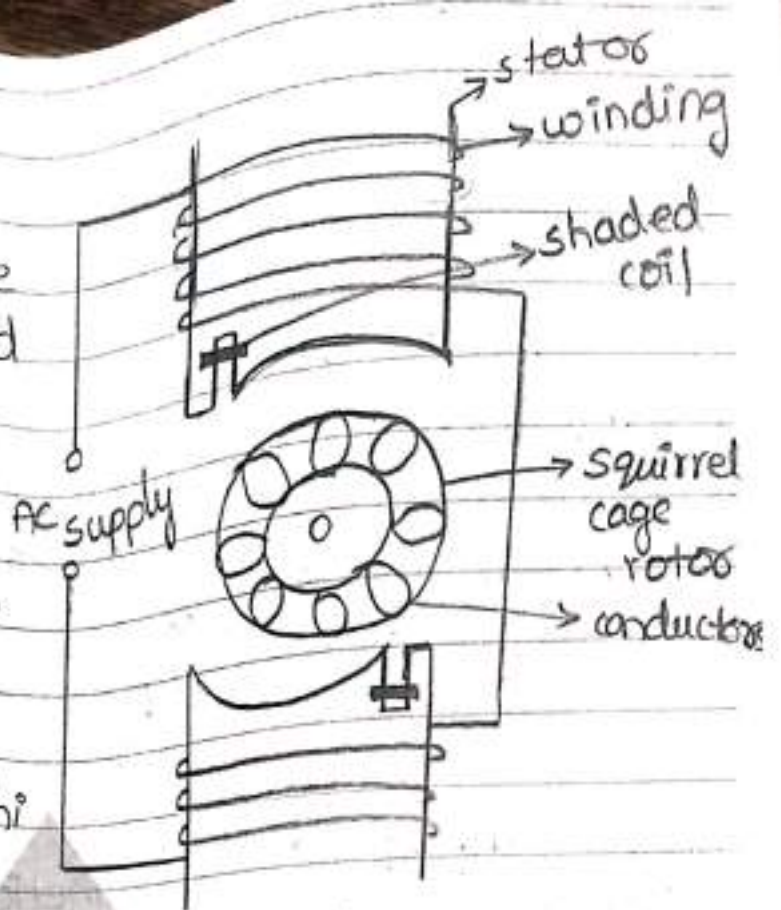

When the AC supply is given to the stator, the current flows through the winding and the flux will be produced. That flux generates the rotating magnetic field. Consider three instants t_1 , t_2 & t_3 .

→ At instant t_1 , the current and flux will be increased. That increased flux produces the induced emf. When it is in the unshaded part, when the current will flow

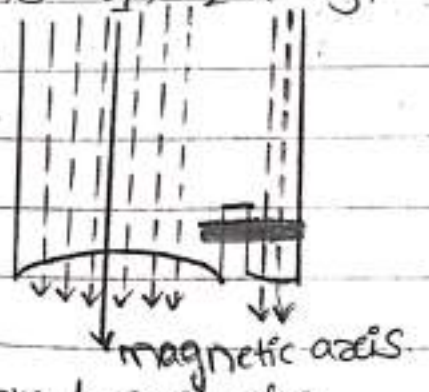

through the shading coil that will produce the flux of its own. By the Lenz law, the flux in the shading coil opposes the main flux. Then the magnetic axis is generated at the center of the pole.

→ At instant t_2 , the current and fluxes are maximum. By the



and in the shading coil also produces the flux and again the flux opposes the main flux the the magnetic axis will move towards to the shading coil.

At instant t_3 , the current and flux will be decreased. Then the emf also decreased. But in the shading coil the current will flow through it and flux will produced. This flux opposes the main flux. Then the magnetic axis moved to the shading coil.

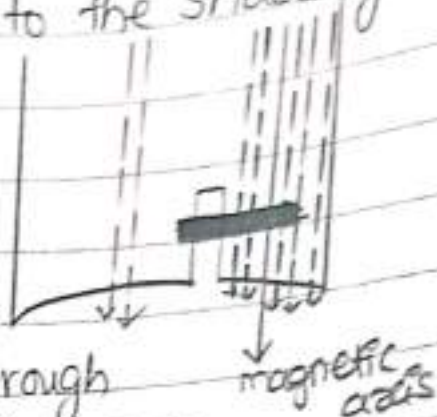

In this, the magnetic axis continuously change to the forward direction.

11. X_d and X_q (slip test):

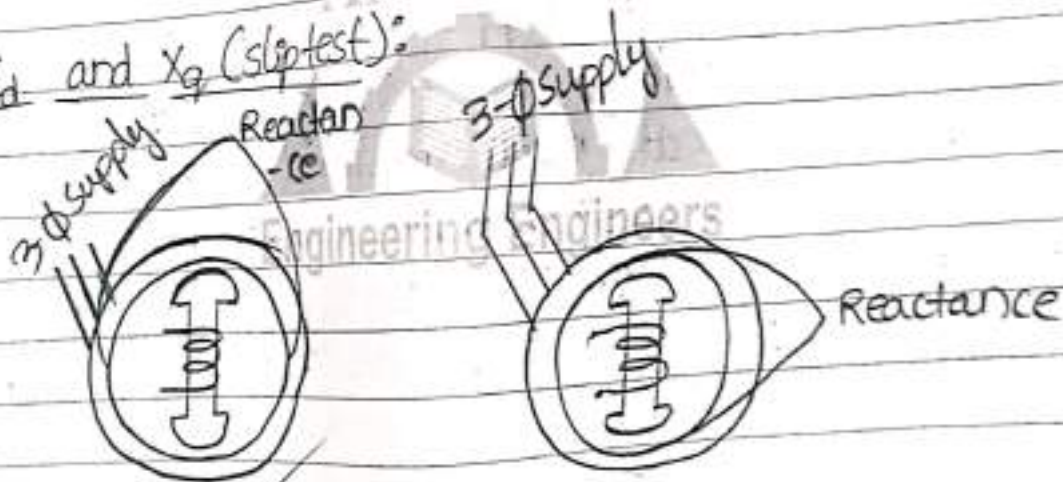

In this, we have to find the X_d and X_q values by the slip test. But the slip test will be conducted by open circuit (O.C) and short circuit (S.C) tests.

First we have to consider a synchronous motor. In synchronous motor there is a stator and rotor and the field windings and

of starting motor. To run the motor, we will give the external supply to the motor. when the external supply is given to the motor, the motor will run at slightly less than the synchronous speed. when we apply the voltage the field winding is opened then by the voltage, the magnitude will reduced (25%) and the ~~ext~~ frequency will increased at the armature terminal. By this, the field poles and rotating mmf will rotates in same direct i.e called the slip speed. By this we can conduct the slip test and take the values of X_d and X_q

$$X_d = \frac{V_{max}}{I_{min}} \quad \text{and} \quad X_q = \frac{V_{min}}{I_{max}}$$

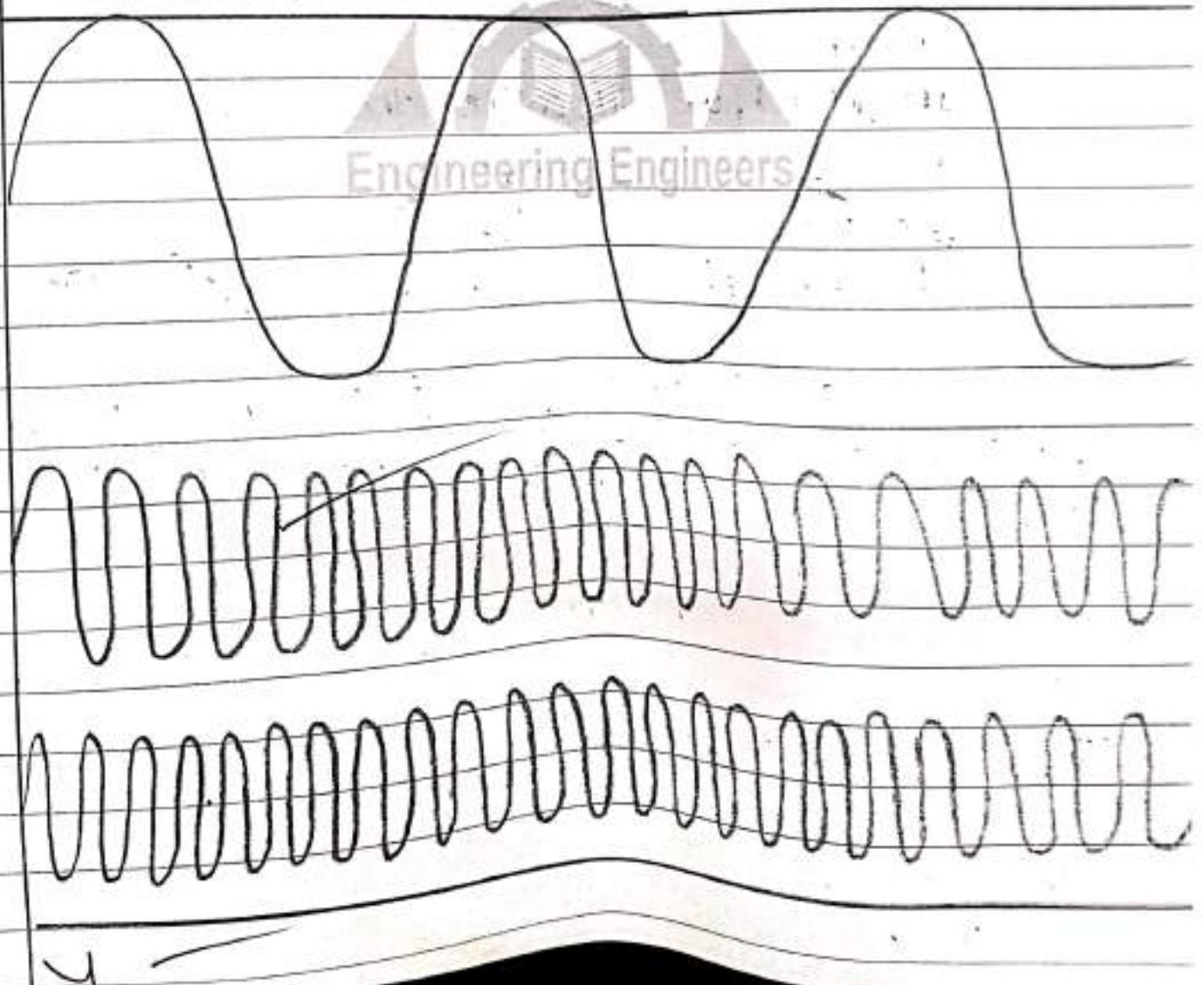

This method is conducted on the synchronous motor and also this method conducts the open circuit (O.C) and short circuit (S.C) test data. In this method the armature resistance and reactance will be neglected.

⇒ In this, The ampere turn field Ampere turn will produces the voltage (V) from the No-load test (O.C).

⇒ And the ϕ By the field Ampere turn overcome the demagnetization of Armature reaction in full-load. This will be from the short circuit (S.C) test,

In general, we will consider the three cases.

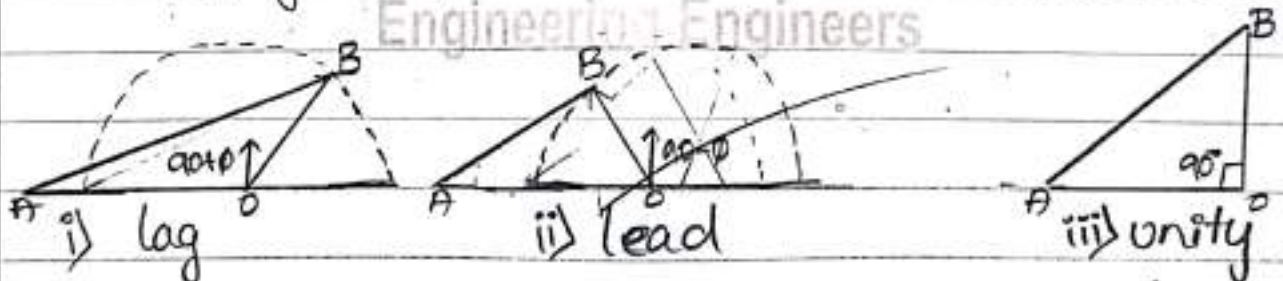

In first case, it is lagging power factor $AB(90 + \phi)^\circ$. and second case, it is leading power factor $AB(90 - \phi)^\circ$. last case, it is unity i.e 90° .

MMF Graph:

The OA represents the field current (I_f) and the OE_0 represents the O.C volts. The regulation for this method is,

$$\% \text{ regulation} = \frac{E_0 - V}{V} \times 100$$

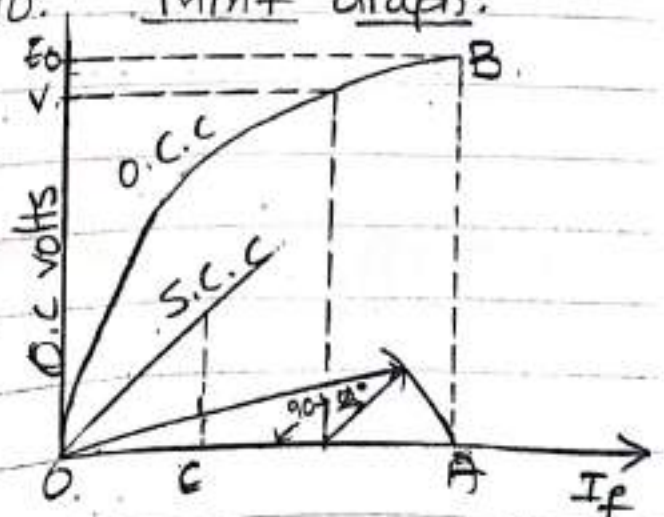

11 Explain the EMF and MMF methods for finding regulations of an alternator. (1)

EMF Method: It is due to Bohm-Eschenberg. Following procedural steps are involved in this method.

1. OCC is plotted from the given data.
2. Similarly SSC is drawn from the data given by the short circuit test. It is a straight line passing through the origin. Both these curves are drawn on a common field current base.

Consider a field current I_f . The O.C. voltage corresponding to field current is E_1 , when winding is short circuited, the terminal voltage is zero.

Hence, it may be assumed that the whole of this voltage E_1 is being used to circulate the armature SC current I_1 against the synchronous impedance Z_s .

$$E_1 = I_1 Z_s = Z_s = \frac{E_1}{I_1}$$

3. Since R_a can be found as discussed earlier

$$X_s = \sqrt{Z_s^2 - R_a^2}$$

4. Knowing R_a and X_s vector diagram (b) can be drawn for any load and any power factor

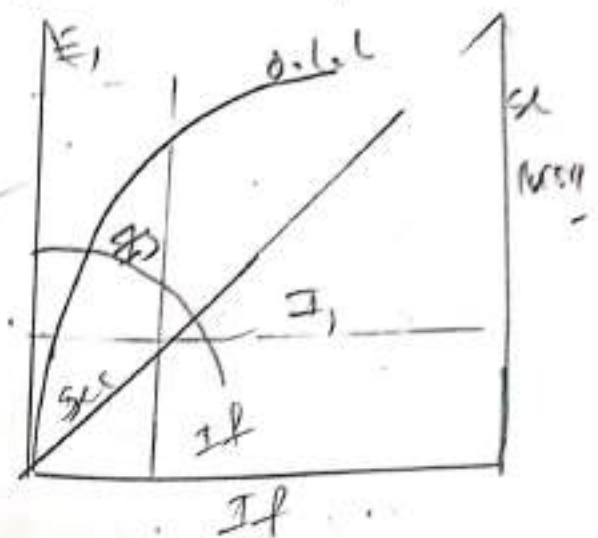

here, $OD = E_0 \therefore E_0 = \sqrt{(I_1 R_a)^2 + (I_1 X_s)^2}$

$$E_0 = \sqrt{(V \cos \theta + I R_a)^2 + (V \sin \theta + I X_s)^2}$$

$$\% \text{ regulation 'up'} = \frac{E_0 - V}{V} \times 100$$

This method is called as pessimistic method.

MMF Method:-

This method also requires OCC and SCC data. In this method armature resistance R_a and leakage reactance X_L is neglected. Therefore, the field current required is only to produce terminal voltage V and to overcome armature reaction on full load.

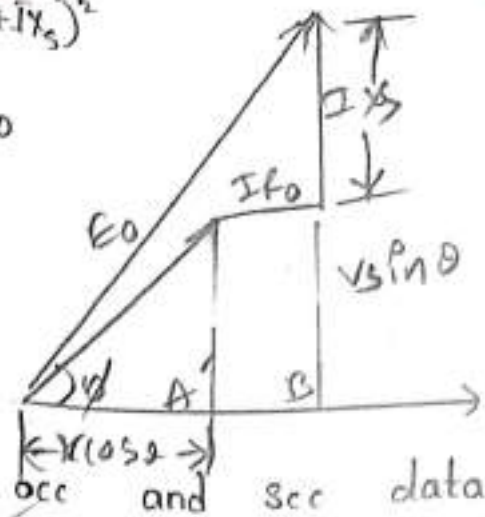

Let us consider the general case when the PF has any value b/w zero and unity.



I_F fig A represents field current I_F required for lagging power factor loads. Where the angle $90 + \theta$ required OB_1 for lagging power factor loads. Where the angle $90 + \theta$ required OB_2 for leading power factor loads. Where the angle $90 + \theta$ required OB_3 for unity power factor loads. Where the angle is 90° fig.

Shown the complete diagram along with OC and SC character.

OA represents field current I_f for normal voltage. OC represents field current I_f required for producing 0 Full load current on short circuit vectors a and b is drawn at angle $(90+\theta)$ for lagging. The total I_f is OB for angle $(90+\theta)$ which corresponding OC voltage E_o .

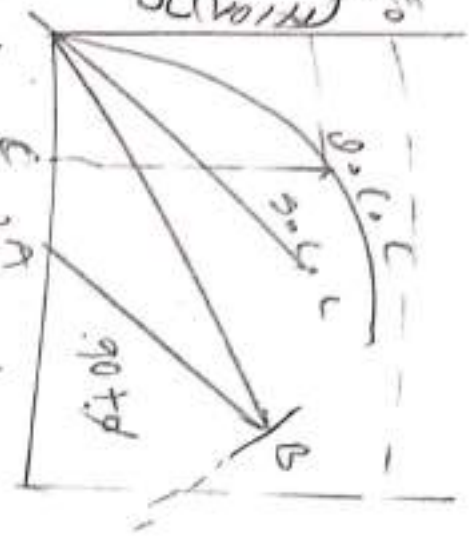

This method is called optimistic method. Hence, it is called optimistic method.

2) Drive the expression for synchronizing power when two alternates connected in parallel.

Consider Figc where machine no.1 is generating and supplying the synchronizing power,

$$P_{sy} = E_1 I_{sy} \cos \phi$$

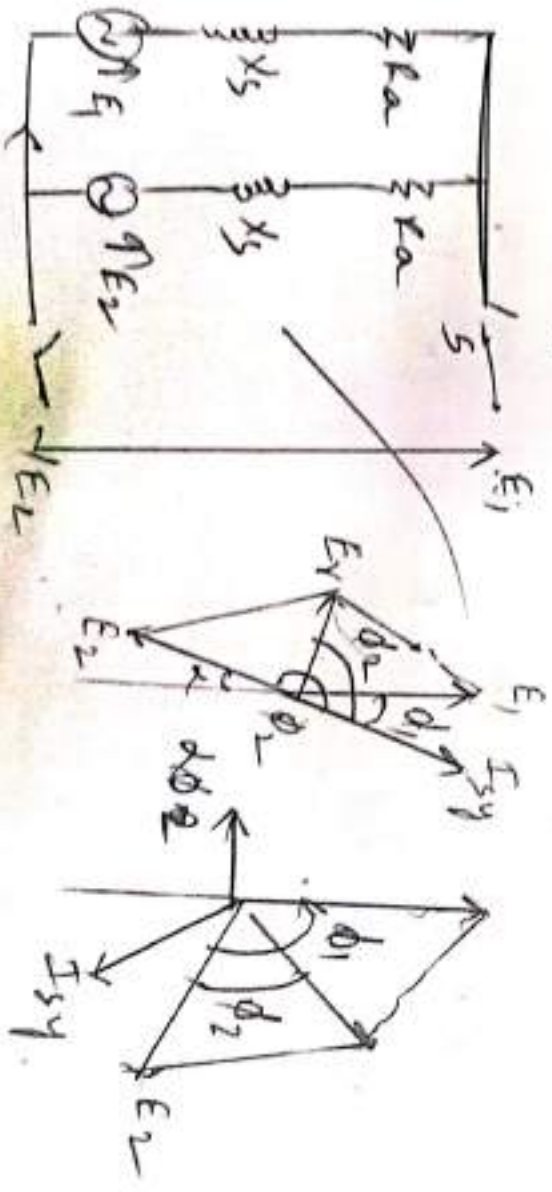

Which is approximately equal to $E_1 I_{sy}$

Since, $\phi_1 = (90^\circ - \theta)$,

$$E_1 I_{sy} \cos \phi_1 = E_1 I_{sy} \cos (90^\circ - \theta) = E_1 I_{sy} \sin \theta = E_1 I_{sy}$$

Since $\cong E_1 I_{sy}$ because $\theta = 90^\circ$ so that $\sin \theta = 1$

Similarly, for machine no. 2, $P_{sy} = E_2 I_{sy} \cos \phi_2$
 \therefore power input to M_2 from M_1 is

$$E_1 I_{sy} = E_2 I_{sy} + \text{cu losses}$$

Let, $E_1 = E_2 = E$

$$\text{Then, } E_r = 2E \cos \left[(180 - \alpha) / 2 \right]$$

$$= 2E \cos \left(90 - \frac{\alpha}{2} \right)$$

$$= 2E \sin \alpha / 2$$

If α is small

$$= 2E \times \alpha / 2$$

$$\boxed{E_r = \alpha E}$$

Here, the angle α is in electrical radians

$$I_{sy} = \frac{E_r}{\text{Syn. Impedance, } 2s} = \frac{E_r}{2X_s} = \frac{\alpha E}{2X_s}$$

Synchronous power supplied by M_1 ,

$$P_{sy} = E_1 I_{sy} \cos \phi_1 = E_1 I_{sy} \cos (90^\circ - \theta) = E_1 I_{sy} \sin \theta = E_1 I_{sy}$$

$$\boxed{P_{sy} = E I_{sy}}$$

$$P_{sy} = E \frac{\alpha E}{2} \cdot 2s = \alpha E^2 / 2s = \frac{\alpha E^2}{2X_s}$$

For 2 alternator 3- ϕ

$$\boxed{P_{sy} = \frac{3\alpha E^2}{2X_s}}$$

3) Explain the principle of operation of synchronous motor. Derive principle of operation.

When 3 ϕ supply is field to the 3 ϕ stator winding, a resultant magnetic field of constant magnitude rotating at synchronous speed, N_s is produced in the stator. Let the stator have two poles N₁ and S₁ rotating clockwise in synchronous speed.

Consider an instant when two stator poles are at position A & B as shown. The position of the rotor poles N₂ and S₂ as shown.

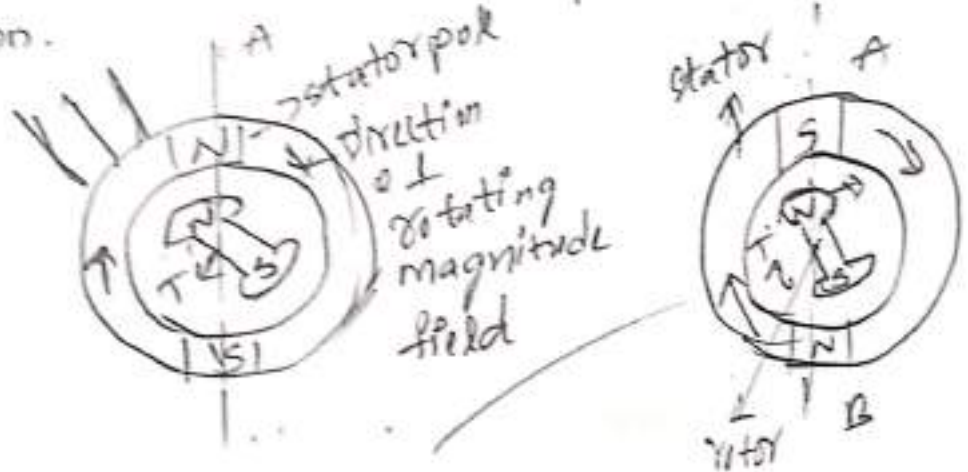

At this instant, rotor is stationary and like poles will try to repel each other and unlike poles will try to attract each other. Due to this rotor will be subjected to a torque in anticlockwise direction as shown (a). But half period of cycle, after the stator poles interchange their positions. During this period

because of inertia, rotor hardly moves from its initial position. This is shown in fig. At the instant, due to unlike poles trying to attract each other, the rotor will be subjected to a torque in clockwise direction.

This continuous and rapid rotation of stator poles the rotor gets subjected to quick reversing torque. Due to inertia of the rotor, it will not respond to such torque and it will remain stationary. Therefore, synchronous motor is not self starting motor.

Power developed :-

From the phasor diagram (b)

$$I_a B = E_b \sin \delta$$

$$= I_a X_s \cos \theta$$

$$\text{or } V I_a \cos \theta = \frac{E_b V}{X_s} \sin \delta \quad (a)$$

Now, $V I_a \cos \theta =$ motor power input/phase

$$P_{in} = \frac{E_b V}{X_s} \sin \delta$$

For 3- ϕ

$$P_{in} = 3 \frac{E_b V}{X_s} \sin \delta$$

Since stator cu loss neglected P_{in} also represents the gross mechanical power P_m

$$P_m = \frac{3 E_b V}{X_s} \sin \delta$$

For gross torque,

$$T_g = 9.55 \frac{P_m}{N_s} \text{ N-m in rpm}$$

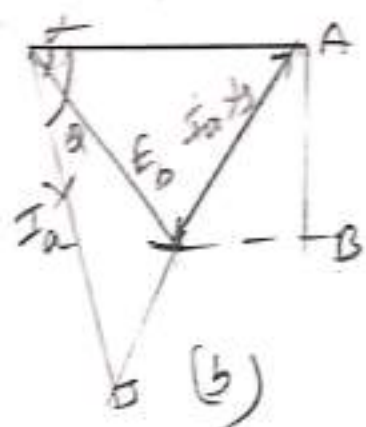
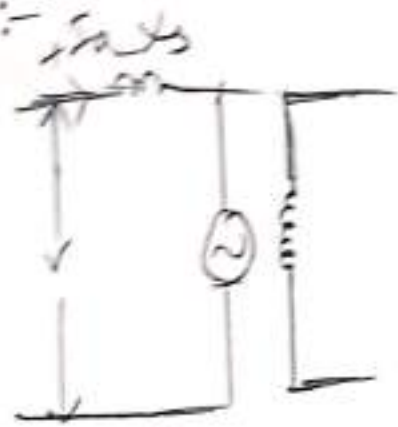

4) Explain constructional features of single phase induction motor and explain how to make single phase induction motor as self starting.

Single phase Induction Motor

Constructionally this motor is, more or less, similar to a polyphase induction motor, except that.

(i) Its stator is provided with a single phase winding and (ii) a centrifugal switch is used in some types of motor, in cross to cut out a winding, used only for starting purpose. It has distributed stator winding and a squirrel cage rotor. When fed from a single phase supply, its stator winding produces a flux which is only alternating i.e., one which alternates along one space axis only. An alternating or pulsating flux acting on a stationary squirrel cage rotor cannot produce a stationary rotation. That is why a single phase motor is not self starting. However, if the rotor of such a machine is given an initial start by hand (or small motor) or otherwise in either direction, the torque arises and the motor immediately accelerates to its final speed.

Making 1- ϕ Induction motor self starting

A single phase induction motor is not self starting to overcome this drawback...

the motor self starting, it is temporarily converted into a two phase motor during start period. For this purpose, the stator of a single phase motor is provided with an extra winding known as starting or auxiliary winding, in addition to the main or running winding. The two windings are spaced 90° electrically apart and are connected in parallel across the single phase supply.

It is so arranged that the phase difference b/w the currents in the two stator winding is very large (ideal value being 90°). Hence, the motor behaves like a two phase motor. These two currents produce a revolving flux and hence make the motor self starting.

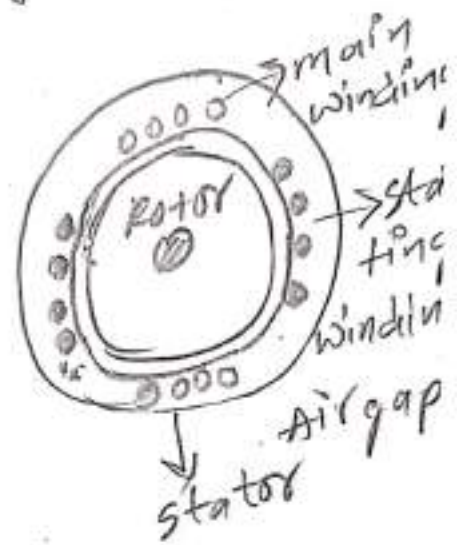

5 Give the applications of split phase motors, as series motor, universal motor and shaded pole motor.

Applications for split phase motor:-

These motors used in fans, blower, office appliance low inertia loads, continuous operating loads.

Applications for AC series motor:-

5

- * Conveyors
- * Stock sized power pumps
- * Traction, hoists, locomotives.
- * hair driers, water heaters.
- * portable drills - etc...

Applications For universal motor:-

- * used in table fans.
- * Grinders.
- * kitchen application
- * polishers.
- * Blowers.

Applications for shaded pole motor:-

- * Vacuum cleaners.
- * electric shavers.
- * wood shapers.
- * calculating machines.
- * sewing machine
- * mixers, etc...

These are the applications for Motors.

5

**DIGITAL NOTES
ON
ELECTRICAL MACHINES-II**

B.TECH III YEAR - I SEM

(2023-24)



**DEPARTMENT OF ELECTRICAL & ELECTRONICS
ENGINEERING**

ANURAG Engineering College

(An Autonomous Institution), NAAC A+

(Approved by AICTE, New Delhi, Affiliated to JNTUH, Hyderabad)

Ananthagiri (V&M), Kodad, Suryapet (Dt). Pin: 508 206.

CONTENTS

Syllabus

Unit-I : Polyphase Induction Motors

**Unit-II: Induction Motors Testing, Starting & Speed
Control Methods**

Unit-III: Synchronous Machines

**Unit-IV: Parallel Operation of Synchronous Machines &
Synchronous Motors**

Unit-V: Single Phase & Special Purpose Motors:

UNIT-1

Polyphase Induction Motors

- Construction details of cage and wound rotor machines
- Production of a rotating magnetic field
- Principle of operation
- Rotor emf and Rotor frequency
- Rotor reactance, rotor current and Power factor at standstill and during operation.
- Rotor power input, Rotor copper loss and mechanical power developed and their interrelation
- Torque equation – expressions for maximum torque and starting torque
- Torque-Slip & Torque-Speed characteristics
- Equivalent circuit – Phasor diagram
- Summary
 - Important concepts and conclusions
 - Important formulae and relations
- Illustrative Problems
- Important Questions

Introduction:

The induction machine is an important class of electric machines which finds wide application as a motor in industry and in its single-phase form in several domestic applications. More than 85% of industrial motors in use today are induction motors. It is substantially a constant-speed motor with a shunt characteristic i.e. a few per cent speed drop from no-load to full-load. It is a singly fed motor (stator- fed), unlike the synchronous motor which requires ac supply on the stator side and dc excitation on the rotor. The torque developed in this motor is due to current induction) in the rotor (Hence the name **Induction** Motor) which is possible only at non-synchronous speed. (Hence it is also asynchronous motor) It is a singly-fed machine i.e. it draws its input power from the mains to set up the rotating magnetic field in the air-gap which is essential for its operation and no external field supply is required.

Induction motor construction:

The stator of an Induction motor is similar to that of a Synchronous machine with three phases wound on it, but with a different type of rotor construction. A typical two-pole stator is shown in the figure below.



Fig: The stator of a typical induction motor showing the stator windings

The rotor core is of laminated construction with slots suitably punched in for accommodating the rotor winding/rotor bars. The punched laminations are stacked and fitted directly onto a shaft in the case of small machines, while in the case of large machines a stack of annular punchings of a suitable cross-sectional area are fitted onto a spider web arrangement on the shaft.

There are two types of induction motor rotors which can be placed inside the stator. One is called a **cage rotor**, (or a *squirrel cage rotor*) and the other is called a **wound rotor**.

A cage type induction motor rotor consists of a series of conducting bars placed in the rotor slots carved in the face of the rotor and shorted at either end by large **shorting rings**. In large machines alloyed copper bars are driven in the slots and are brazed onto copper end-rings. Small Rotors usually have a die cast aluminum bars wherein the end-rings are also cast simultaneously with the same material by using a suitable mould. This is an economical process and is generally employed in mass production of small size induction motors.

Figures below show cage type induction motor rotors and the cutaway view of complete Squirrel Cage Induction Motors.

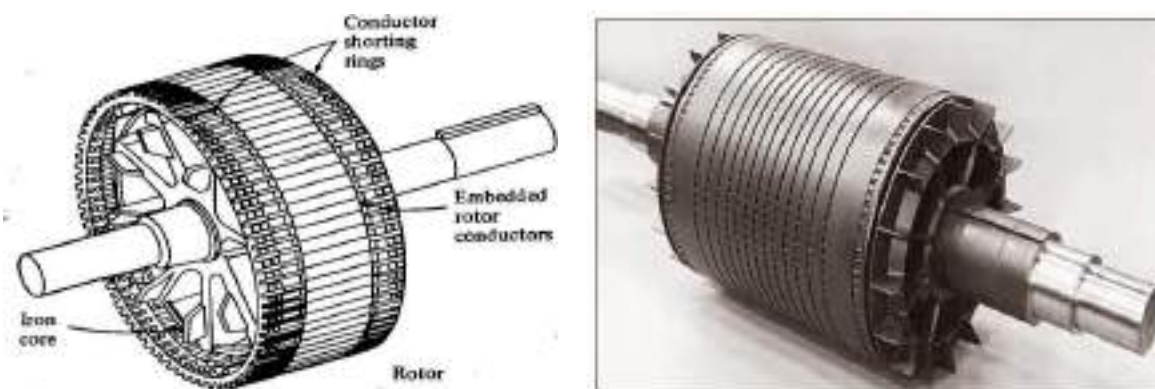

Figure :(a) Sketch of cage rotor. (b) A typical cage rotor.



(a) Cutaway diagram of a typical small cage rotor induction motor
(b) Cutaway diagram of a typical large cage rotor induction motor.

The rotor circuit of a squirrel-cage motor cannot be tampered with and the machine has a low starting torque, while it has excellent running performance. Therefore, it cannot be used where a high starting torque is required. The starting torque of a squirrel-cage motor can be improved by employing either a double cage rotor or a deep-bar rotor. Such type of construction serves the purpose of a medium starting torque requirement.

The rotor has a lesser number of slots than the stator and these must be a non integral multiple of stator slots so as to prevent magnetic locking of rotor and stator teeth at the time of starting. Further for the same purpose rotor teeth are skewed (twisted) slightly.

The slots in the induction machine are semi-enclosed so as to increase the permeance per pole so that the magnetization current, which is responsible for less than unity power factor of this motor, is kept within limits.

The other type of rotor is a wound rotor similar to that of the stator except that the number of slots is lesser and fewer turns per phase of a heavier conductor are used. A **wound rotor** has a complete set of three-phase windings placed in the slots of the rotor core that are similar to the windings on the stator. The three phases of the rotor windings are usually Y-connected. The ends of the three rotor windings are brought out and connected to the slip rings on the rotor's shaft. The slip-rings are tapped by means of copper-carbon brushes which are riding on the slip rings. Hence motors with such **wound rotors** are also called as **Slip Ring Induction Motors**.

Two wound rotors are shown in figure (a) below, and a complete wound-rotor induction motor is shown in the figure (b) below.



Fig: Typical wound rotors for induction motors. (Notice the slip rings and the bars connecting the rotor Windings to the slip rings)

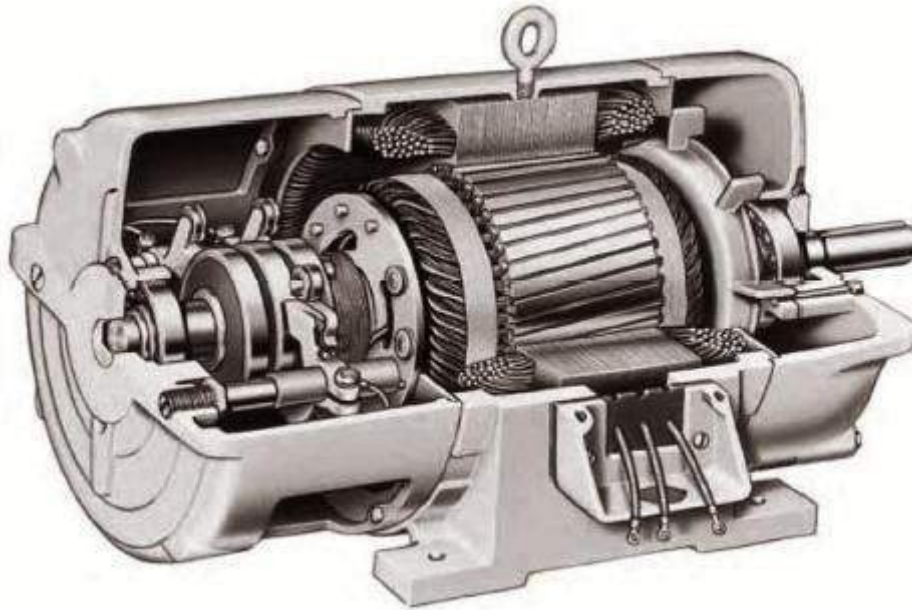

Fig: Cut away diagram of a wound-rotor induction motor (Notice the brushes and slip rings. Also notice that the rotor windings are skewed to eliminate slotharmonics)

Wound- rotor construction is generally employed for large size machines to be used where the starting torque requirements are stringent. Wound-rotor induction motors are more expensive than cage induction motors, and they require higher maintenance because of the wear associated with their brushes and slip rings. External resistance can be included in the rotor circuit through slip- rings for reducing the starting current and simultaneously improving the starting torque.

The connection diagram of a 3-phase slip-ring induction motor with delta-connected stator and star connected rotor is shown in the figure below. The rotor winding is connected to slip rings which are shorted through external resistances at the time of starting. The resistances are cut-out as the motor attains full speed.

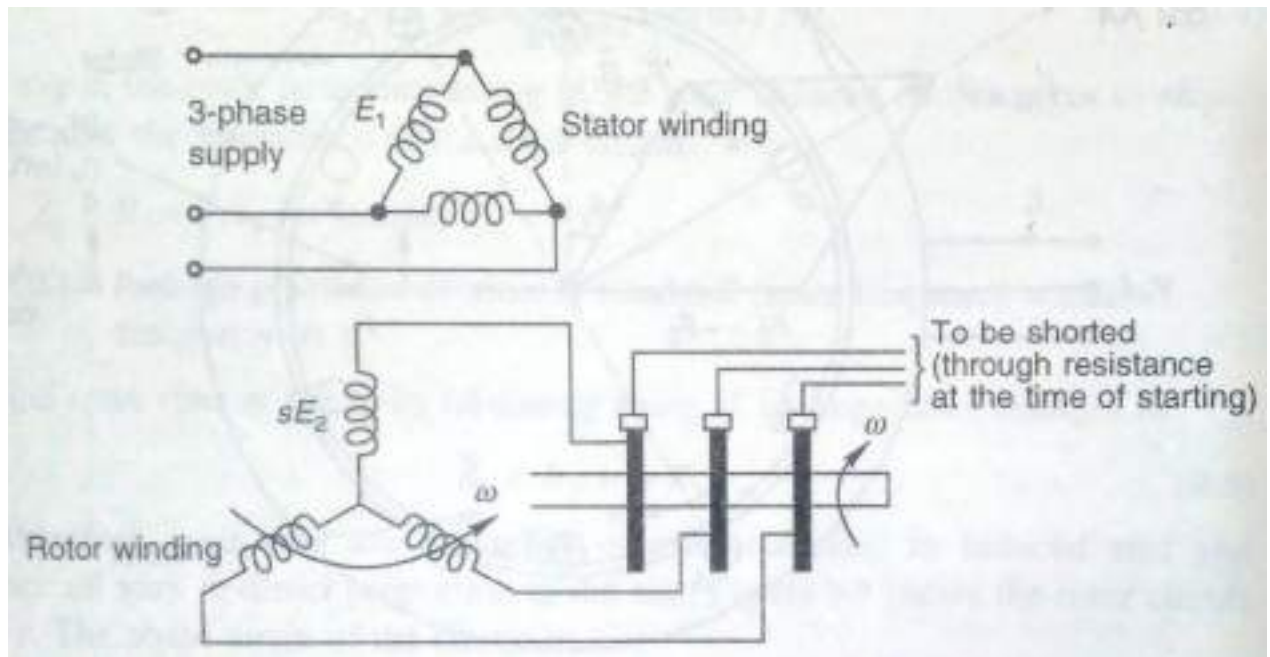

Figure: 3-phase slip-ring induction motor—connection diagram

Production of a rotating magnetic field:

The torque induced in a loop of wire in an external magnetic field is proportional to the strength of the loop's magnetic field, the strength of the external magnetic field, and the sine of the angle between them. This is also true of real ac machines. In general, the torque in any real machine will depend on four factors:

1. The strength of the rotor magnetic field
2. The strength of the external magnetic field
3. The sine of the angle between them
4. A constant representing the construction of the machine (geometry. etc.)

Hence we can say that if two magnetic fields are present in a machine, then a torque will be created which will tend to line up the two magnetic fields. If one magnetic field is produced by the stator of an ac machine and the other one is produced by the rotor of the machine, then a torque will be induced in the rotor which will cause the rotor to rotate and align itself with the stator magnetic field.

If there is some way to make the stator magnetic field rotate, then the induced torque in the rotor would cause it to constantly rotate so as to "chase" the stator magnetic field around in a circle. This, in a nutshell, is the basic principle of all ac motors' operation.

The fundamental principle of an ac machine operation is that *if a three-phase set of currents, each of equal magnitude and differing in phase by 120° , flows in a set of three-phase windings located 120° (mechanical) apart around the surface of the machine, then it will produce a rotating magnetic field of constant magnitude.* The rotating magnetic field concept is illustrated in the simplest case by an empty stator containing just three coils, each 120° apart as shown in figure 'a' below. Since such a winding produces only one north and one south magnetic pole, it is a two pole winding.

To understand the concept of the rotating magnetic field, we will apply a set of currents to the stator of Figure below and see what happens at specific instants of time. Assume that the currents in the three coils are given by the

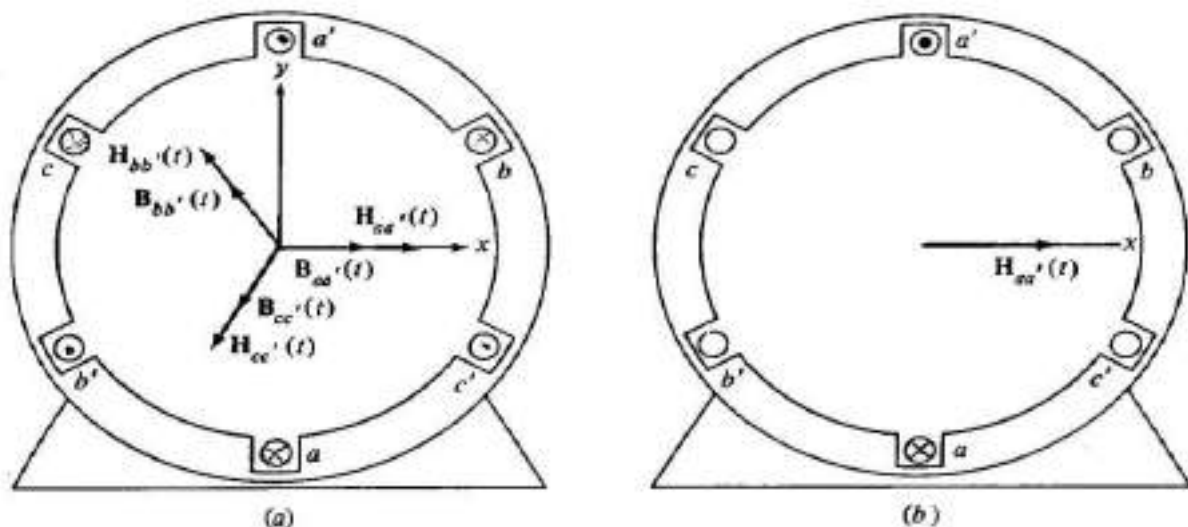

equations

A simple three-phase stator. Currents in this stator are assumed positive if they flow into the Unprimed end and out the primed end of the coils. The magnetizing intensities produced by each coil are also shown.

(b) The magnetizing intensity vector $H_{aa'}(t)$ produced by a current flowing in coil aa' .

$$i_{aa'}(t) = I_M \sin \omega t \text{ Amps}$$

$$i_{bb'}(t) = I_M \sin(\omega t - 120^\circ) \text{ Amps}$$

$$i_{cc'}(t) = I_M \sin(\omega t - 240^\circ) \text{ Amps}$$

The current in coil aa' flows into the ' a' ' end of the coil and out at the ' a ' end of the coil. It produces the magnetic field intensity

$$H_{aa'}(t) = H_M \sin \omega t / \theta^\circ \text{ A} \cdot \text{turns} / \text{m}$$

where θ° is the spatial angle of the magnetic field intensity vector, as shown in the figure (b) above. The direction of the magnetic field intensity vector $H_{aa'}(t)$ is given by the right-hand rule: If the fingers of the right hand curl in the direction of the current flow in the coil, then the resulting magnetic field is in the direction that the thumb points. Notice that the magnitude of the magnetic field intensity vector $H_{aa'}(t)$ varies sinusoidally in time, but the direction of $H_{aa'}(t)$ is always constant.

Similarly, the magnetic field intensity vectors $H_{bb'}(t)$ and $H_{cc'}(t)$ are also given by

$$H_{bb'}(t) = H_M \sin(\omega t - 120^\circ) / 120^\circ \text{ A} \cdot \text{turns} / \text{m}$$

$$H_{cc'}(t) = H_M \sin(\omega t - 240^\circ) / 240^\circ \text{ A} \cdot \text{turns} / \text{m}$$

The flux densities resulting from these magnetic field intensities given by the basic relation $B = \mu H$ are:

$$B_{aa'}(t) = B_M \sin \omega t / \theta^\circ \text{ T}$$

$$B_{bb'}(t) = B_M \sin(\omega t - 120^\circ) / 120^\circ \text{ Tesla}$$

$$B_{cc'}(t) = B_M \sin(\omega t - 240^\circ) / 240^\circ \text{ Tesla}$$

Tesla

Where $B_M = \mu H_M$. The currents and their corresponding flux densities can be examined at specific times to determine the resulting net magnetic field in the stator.

For example, at time $\omega t = 0^\circ$, the magnetic field from coil aa' will be:

$$\mathbf{B}_{aa'} = 0$$

The magnetic field from coil bb' will be:

$$\mathbf{B}_{bb'} = B_M \sin(-120^\circ) / 120^\circ$$

And the magnetic field from coil cc' will be:

$$\mathbf{B}_{cc'} = B_M \sin(-240^\circ) / 240^\circ$$

The total magnetic field from all three coils added together will be

$$\begin{aligned} \mathbf{B}_{net} &= \mathbf{B}_{aa'} + \mathbf{B}_{bb'} + \mathbf{B}_{cc'} \\ &= 0 + (-\sqrt{3}/2 B_M) / 120^\circ + (\sqrt{3}/2 B_M) / 240^\circ \\ &= 1.5 B_M / -90^\circ \end{aligned}$$

The resulting net magnetic field is shown in figure (a) below.

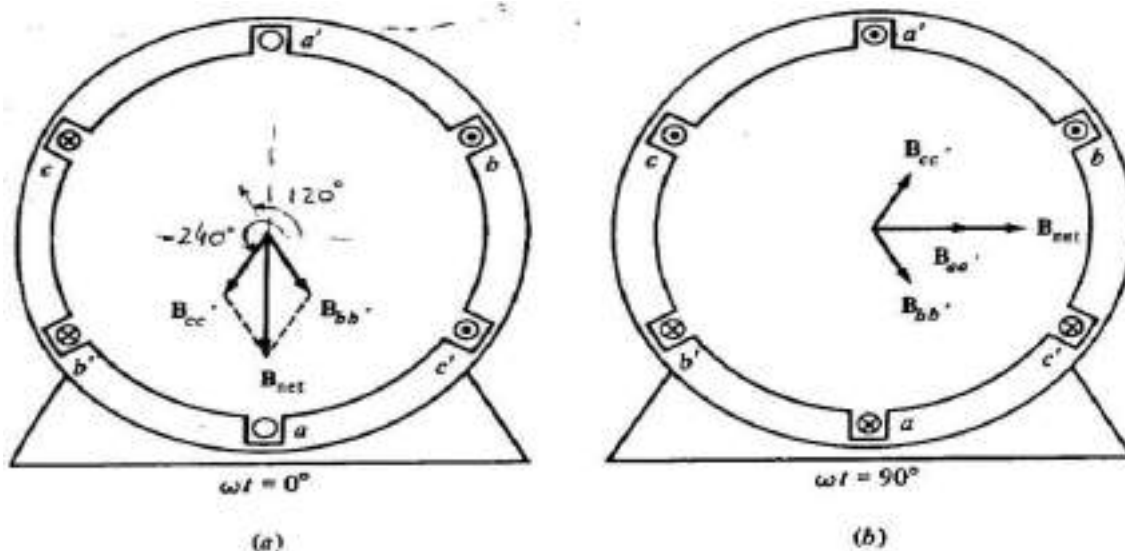

(a) The vector magnetic field in a stator at time $\omega t = 0^\circ$. (b) The vector magnetic field in a stator at Time $\omega t = 90^\circ$.

As another example, let us look at the magnetic field at time $\omega t = 90^\circ$. At that time, the currents are:

$$i_{aa'}(t) = I_M \sin 90^\circ \text{ Amps}$$

$$i_{bb'}(t) = I_M \sin(-30^\circ) \text{ Amps}$$

$$i_{cc'}(t) = I_M \sin(-150^\circ) \text{ Amps}$$

and the magnetic fields are

$$\mathbf{B}_{aa'}(t) = B_M / 0^\circ \quad \text{Tesla}$$

$$\mathbf{B}_{bb'}(t) = -0.5 B_M / 120^\circ \quad \text{Tesla}$$

$$\mathbf{B}_{cc'}(t) = -0.5 B_M / 240^\circ \quad \text{Tesla}$$

The resulting net magnetic fields are:

$$\begin{aligned} \mathbf{B}_{\text{net}} &= \mathbf{B}_{aa'} + \mathbf{B}_{bb'} + \mathbf{B}_{cc'} \\ &= B_M / 0^\circ + (-0.5 B_M) / 120^\circ + (-0.5 B_M) / 240^\circ \\ &= 1.5 B_M / 0^\circ \end{aligned}$$

The resulting magnetic field is shown in the figure (b) above. Notice that although the *direction* of the magnetic field has changed, the *magnitude* is constant. The magnetic field is maintaining a constant magnitude while rotating in a counter clockwise direction. This explains the concept of the production of a rotating magnetic field.

Principle of operation & The Development of Induced Torque in an Induction Motor:

When current flows in the stator, it will produce a magnetic field in stator such that \mathbf{B}_s (stator magnetic field) will rotate at a speed:

$$n_s = 120 \cdot f_s / P$$

Where f_s is the system frequency in hertz and P is the number of poles in the machine. This rotating magnetic field \mathbf{B}_s passes over the rotor bars and induces a voltage in them. The voltage induced in the rotor is given by:

$$e_{\text{ind}} = (\mathbf{v} \times \mathbf{B}) l$$

Where \mathbf{v} is the velocity of the Rotor bars relative to the Stator magnetic field

\mathbf{B} = magnetic flux density vector

And l = length of the rotor bar in the magnetic field.

Hence there will be rotor current flow which would be lagging due to the fact that the rotor is inductive. And this rotor current will produce a magnetic field at the

rotor, B_r . Hence the Interaction between these two magnetic fields would give rise to an induced torque:

$$T_{ind} = k \cdot B_R \times B_S$$

The torque induced would accelerate the rotor and hence the rotor will rotate. However, there is a finite upper limit to the motor's speed due to the following interactive phenomenon:

If the induction motor's speed increases and reaches synchronous speed then the rotor bars would be stationary relative to the magnetic field

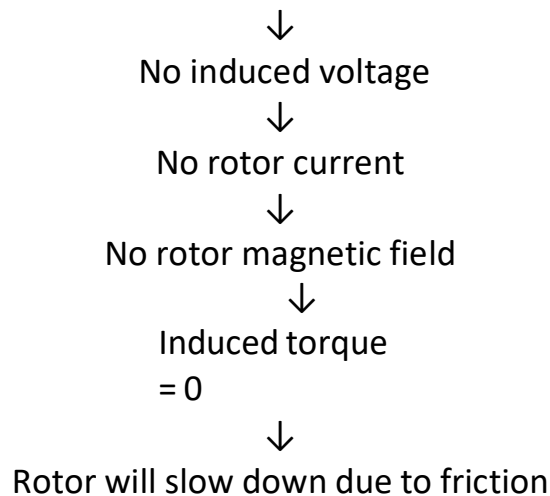

Conclusion: An induction motor can thus speed up to such a near synchronous speed where the induced torque is just able to overcome the load torque but it can never reach synchronous speed.

The Concept of Rotor Slip:

The induced voltage in the rotor bar is dependent upon the *relative speed between the stator Magnetic field and the rotor*. This is termed as slip speed and is given by:

$$n_{slip} = n_{sync} - n_m$$

Where n_{slip} = slip speed of the machine

n_{sync} = speed of the magnetic field (also motor's synchronous speed) and

n_m = mechanical shaft speed of the motor.

Apart from this we can describe this relative motion by using the concept of **slip** which is the relative speed expressed on a per-unit or percentage basis. Slip ' s ' is defined as:

$$s = \frac{n_{\text{slip}}}{n_{\text{sync}}} (\times 100\%)$$

$$s = \frac{n_{\text{sync}} - n_m}{n_{\text{sync}}} (\times 100\%)$$

On percentage basis and is defined as

$$S = (N_{\text{sync}} - N_m) / N_{\text{sync}}$$

On per unit basis.

Slip 'S' is also expressed in terms of angular velocity ω (Rad/Sec) as given below:

$$s = \frac{\omega_{\text{sync}} - \omega_m}{\omega_{\text{sync}}} (\times 100\%)$$

It can be noted that if the motor runs at synchronous speed the slip 'S' =0 and if the rotor is standstill then the slip 'S' =1. It is possible to express the mechanical speed of the Rotor in terms of Slip S and synchronous speed n_{sync} as given below:

$$n_m = (1 - s)n_{\text{sync}}$$

$$\omega_m = (1 - s)\omega_{\text{sync}}$$

Rotor e.g. , Rotor frequency ,Rotor reactance, rotor current and Power factor at standstill and during operation: (Effect of Slip on Rotor parameters)

In case of a transformer, the frequency 'f' of the induced e.m.f. in the secondary is same as the applied voltage to the primary. But in the case of an Induction motor, the frequency of the induced voltage in the rotor is not same as that of the applied voltage to the stator and it depends on the slip. At start, the speed $N = 0$, the slip 's' = 1 and the frequency of the induced voltage in the rotor is same as

that of the voltage applied to the stator. As the motor picks up speed, the slip becomes smaller and hence the frequency of the induced e.m.f. in the rotor also becomes lesser. Due to this, some of the Rotor parameters also get affected. Let us study the effect of slip on the following parameters.

1. Rotor frequency
2. Magnitude of induced e.m.f in rotor.
3. Rotor reactance
4. Rotor power factor and
5. Rotor current.

Rotor frequency:

The speed of the Stator rotating magnetic field is given by

$$N_s = 120.f_s/P \quad (1)$$

Where f_s is the system (supply) frequency in hertz and P is the number of poles in the machine. At start the speed $N = 0$, the slip ' s ' = 1 and the rotor which is stationary has maximum relative motion i.e. same as that of the R.M.F. Hence the frequency of the induced voltage in the rotor is same as that of the voltage applied to the stator. As the motor picks up speed the relative speed of the Rotor with respect to the Stator RMF decreases and becomes equal to slip speed ($N_s - N$). As we know the frequency and magnitude of induced e.m.f in the rotor depends on the rate of change of cutting flux i.e. relative speed ($N_s - N$). Hence in running condition the magnitude and frequency of induced voltage decreases. The rotor is wound for the same number of poles as that of the Stator i.e. P . If f_r is frequency of the Rotor induced e.m.f. in running condition at slip speed of ($N_s - N$) (when the motor is running at a speed of N) then there exists a fixed relation between slip speed ($N_s - N$), f_r and P just as in the case of stator. So for Rotor we can write:

$$N_s - N = 120f_r/P \quad (2)$$

Dividing equation (2) by (1) we get:

$$(N_s - N)/N_s = (120f_r/P) / (120.f_s/P)$$

But $(N_s - N) / N_s = \text{Slip 's'}$ and Hence $s = f_r / f_s$ or $f_r = sf_s$

Thus we can say that the frequency of the Rotor induced e.m.f f_r is slip 's' times the supply frequency f_s .

As slip of an induction motor is normally in the range of 0.01 to 0.05 the Rotor frequency is very small in the running condition.

Rotor Induced e.m.f:

We know that just like the induced frequency, the induced e.m.f is also is proportional to the relative speed between the Rotor and the stator.

Let E_2 = Rotor induced e.m.f when it is standstill i.e. relative speed is N_s

And E_{2r} = Rotor induced e.m.f when it is running i.e. relative speed is $N_s - N$

So we have $E_2 \propto N_s$ i.e. $E_2 = kN_s$ ----- (1)

And $E_{2r} \propto N_s - N$ i.e. $E_{2r} = k(N_s - N)$ ----- (2)

Dividing the second equation by first equation we get: $E_{2r} / E_2 = (N_s - N) / N_s$.

But $(N_s - N) / N_s = \text{slip 's'}$. Hence we get finally:

$$E_{2r} = s E_2$$

i.e. The magnitude of the *Rotor e.m.f. in running condition* also gets reduced to *slip* times the magnitude of the *e.m.f. in standstill condition*.

Rotor Resistance and Reactance:

Just like the stator, Rotor winding also has its own Resistance and Reactance and let them be $R_2 \Omega / Ph$ and $X_2 \Omega / Ph$ respectively.

We know that Resistance of a coil is independent of frequency while it's Reactance is given by $X = 2\pi fL$ where L is the Inductance of the coil. Thus

$$X_2 (\text{@ standstill}) = 2\pi f_s L$$

And since $f_r = sf_s$

$$X_{2r} (\text{@ running condition}) = 2\pi f_r L = 2\pi sf_s L = s X_2$$

$$\text{i.e. } X_{2r} = s X_2$$

Thus we can conclude that the Resistance of the Rotor which is independent of

frequency remains the same at both standstill and in running condition while the reactance which is dependent on the frequency gets reduced to slip times the Reactance in standstill condition.

Then we have Rotor impedance Z_2 per phase as:

$$Z_2 = R_2 + j X_2 = \sqrt{R_2^2 + X_2^2} \quad \Omega / \text{Ph (@standstill)}$$

$$\text{And } Z_{2r} = R_2 + j X_{2r} = \sqrt{R_2^2 + (sX_2)^2} \quad \Omega / \text{Ph (@ Running condition)}$$

Rotor power factor:

We know that the power factor any inductive circuit is given by:

$$\cos \theta = R/Z$$

Using the above values of Resistance and impedance of the Rotor in both standstill and running conditions in this relation for p.f. we get:

$$\cos \theta = R_2/Z_2 = R_2/\sqrt{R_2^2 + X_2^2} \quad \Omega / \text{Ph (@standstill) and}$$

$$\cos \theta_r = R_2/Z_{2r} = R_2/\sqrt{R_2^2 + (sX_2)^2} \quad (@ \text{ Running condition})$$

The corresponding impedance triangles for both standstill and running conditions are shown in the figures (a) and (b) below.

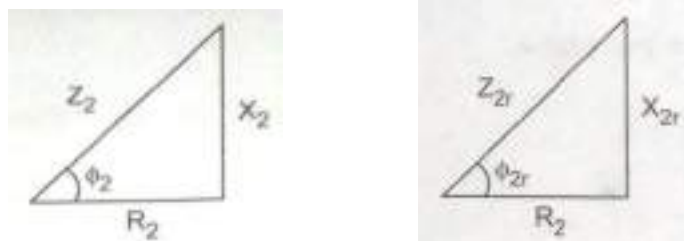

Fig: (a) Impedance triangle at standstill (b): Impedance triangle while running

Note: As Rotor circuit is inductive power factor is always lagging.

Rotor current:

The rotor currents (per phase) in both cases are given by (using the basic relation $I = E/Z$):

$$I_2 = E_2 / Z_2 = E_2 / \sqrt{R_2^2 + j X_2^2} (\text{@standstill}) \text{ and}$$

$$I_{2r} = E_{2r} / Z_{2r} = E_{2r} / \sqrt{R_2^2 + j X_{2r}^2} = s E_2 / \sqrt{R_2^2 + (sX_2)^2} (\text{@ Running condition})$$

Note: (θ_{2r} is the phase angle between the Rotor voltage E_{2r} and Rotor current I_{2r} which decides the power factor while the motor is running)

The corresponding Rotor equivalent circuits for both standstill and running conditions are shown in the figures (a) and (b) below.



Fig (a): Rotor equivalent circuit at standstill (b): Rotor eq. circuit while running

Rotor power input, Rotor copper loss and mechanical power developed and their interrelation:

An induction motor can be basically described as a rotating transformer. Its input is a 3 phase system of voltages and currents. For an ordinary transformer, the output is electric power from the secondary windings. The secondary windings in an induction motor (the rotor) are shorted and so no electrical output exists from normal induction motors. Instead, the output power is mechanical. The power flow diagram given below shows how the Input Electrical power given to the Induction Motor stator gets converted into Mechanical power at the Rotor end and what are the losses taking place in between.

The input power to an induction motor P_{in} is in the form of 3-phase electric

voltages and currents and is given by:

$$P_{IN} = \sqrt{3} V_L I_L \cos \theta$$

Where V_L , I_L are line values of voltage & current and $\cos \theta$ is motor power factor.

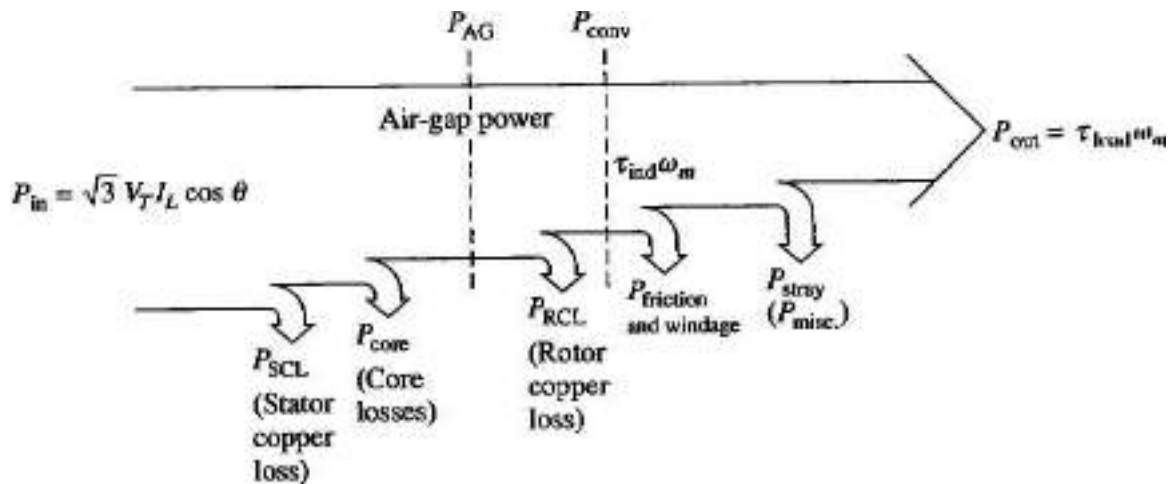

Fig: Power flow diagram of an Induction motor.

The first losses encountered in the machine are I^2R losses in the stator windings (stator copper loss P_{SCL}). Then, some amount of power is lost as hysteresis and eddy currents in the stator (P_{core}). The power remaining at this point is transferred to the rotor of the machine across the air gap between the stator and rotor. This power is called the air gap power P_{AG} of the machine like.

$$P_{AG} = P_{IN} - (P_{SCL} + P_{core}) = T_{ind} \cdot \omega_s$$

After the power is transferred to the rotor, some of it is lost as I^2R losses (the rotor copper loss P_{RCL}), and the rest is converted from electrical to mechanical form (P_{CONV}). i.e.

$$P_{CONV} = P_{AG} - P_{RCL} = T_{ind} \cdot \omega_m$$

When this mechanical power is delivered to the load through the rotor shaft again some more power is lost as mechanical losses known as friction and windage losses $P_{F\&W}$ and then again some unaccounted losses known as stray losses P_{MISC} . Finally the remaining power is the net output power delivered by the Motor to the load as P_{OUT} i.e.

$$P_{OUT} = P_M - (P_{F\&W} + P_{MISC}) = T_{load} \cdot \omega_m$$

This total power flow along with the losses in between is shown in the diagram above.

The core losses do not occur in the stator side alone as shown in the figure above. The core losses of an induction motor come partially from the stator circuit and partially from the rotor circuit. Since an induction motor normally operates at a speed near synchronous speed, the relative motion of the magnetic fields over the rotor surface is quite slow, and the rotor core losses are very tiny compared to the stator core losses. Since the largest fraction of the core losses comes from the stator circuit, all the core losses are lumped together and shown as if they are occurring at the stator end. The *higher* the speed of an induction motor, the *higher* the friction, windage, and stray losses. On the other hand, the *higher* the speed of the motor (up to n_{sync}), the *lower* its core losses. Therefore, these three categories of losses are sometimes lumped together and called as *rotational losses*. The total rotational losses of a motor are often considered to be constant with changing speed, since the component losses change in opposite directions with a change in speed as explained.

Torque equation – expressions for maximum torque and starting torque:

Torque equation: The torque developed in an Induction motor depends on the following factors.

1. The stator magnetic field ϕ which induces e.m.f. in the rotor.
2. The magnitude of the Rotor current I_{2r} in running condition.
3. The power factor ' $\cos \theta_{2r}$ ' of the Rotor circuit in running condition.

Thus the expression for Torque can be given as: $T_a \propto \phi \cdot I_{2r} \cdot \cos \theta_{2r}$ -----(1)

We know that the flux ϕ produced by the stator is proportional to the voltage applied to the stator E_1 . And similarly the Stator and Rotor voltages E_1 and E_2 are related to each other by a ratio of their effective number of turns ' K '.

i.e. $\phi \propto E_1$ and $E_1 / E_2 = K$ and so effectively $\phi \propto E_2$ ----- (2)

We have earlier obtained expressions for the Rotor current and Rotor power factor as:

$$I_{2R} = E_{2r} / Z_{2r} = s E_2 / \sqrt{R_2^2 + (sX_2)^2} \text{ (@ Running condition)} \quad \text{-----} \quad (3)$$

$$\cos \theta_{2R} = R_2 / Z_{2r} = R_2 / \sqrt{R_2^2 + (sX_2)^2} \text{ (@ Running condition)} \quad \text{-----} \quad (4)$$

Using the above equations at (2) ,(3) and (4) in equation (1) we get :

$$T \propto [s E_2^2 R_2 / R_2^2 + (sX_2)^2]$$

Where 'k' is total the constant of proportionality and can be shown that $k = 3/2\pi n_s$ where $n_s =$ synchronous speed in r.p.s. = $N_s/60$ ($N_s =$ Synchronous speed in RPM). Substituting this value of the constant 'k' in the above expression for Torque we get finally

$$T = (3/2\pi n_s) [s E_2^2 R_2 / R_2^2 + (sX_2)^2] \quad \text{N-m}$$

So, **Torques** at any load condition can be can be obtained if **Slip's'** at that load and **Standstill Motor parameters** are known.

Starting Torque: Is the torque at the time of start in an induction motor and can be obtained by substituting the corresponding value of slip 's' . At the time of starting the speed $N = 0$ and hence the slip 's' = 1. Using this value of 's' in the above equation for Torque we get the starting torque as :

$$T_{st} = (3/2\pi n_s) [E_2^2 R_2 / R_2^2 + X_2^2]$$

Maximum torque:

Condition for maximum Torque:

As can be seen from the above Torque equation, the torque depends only on the slip with which the motor is running since all the other parameters are constant. Supply voltage to the stator is usually rated and hence constant and the turns ratio between Stator and Rotor is also constant. Hence E_2 is constant. Similarly R_2 ,

X_2 and n_s are constants in an Induction motor. So to find out the maximum torque we have to find out at what slip maximum torque occurs. Hence, mathematically we can write the condition for maximum Torque as:

$$dT/ds = 0$$

where $T = k [s E_2^2 R_2 / R_2^2 + (sX_2)^2]$. While evaluating the above differential it is to be noted that in the above expression for Torque all the parameters like E_2, R_2 and X_2 are also constants apart from the constant of proportionality 'k' and the only variable is 's' and this term is present in both numerator and denominator. Hence we can differentiate the expression for torque using the formula for differential of a quotient (u/v) after taking out all the constant terms out of the differential as shown below.

$$T = (k E_2^2 R_2) [s / R_2^2 + s^2 X_2^2]$$

Now differentiating the term within the square brackets and equating the numerator alone to zero we get:

$$s \cdot d/ds [R_2^2 + s^2 X_2^2] - [R_2^2 + s^2 X_2^2] d/ds (s) = 0$$

i.e. $s \cdot [2 s X_2^2] - [R_2^2 + s^2 X_2^2] \cdot 1 = 0$

i.e. $2 s^2 X_2^2 - s^2 X_2^2 - R_2^2 = 0$

i.e. $s^2 = R_2^2 / X_2^2$

Or finally $s = R_2 / X_2$

So we conclude that the torque is maximum at a slip ' $s' = R_2 / X_2$ or in other words the slip at maximum torque ' s_m ' is given by:

$$'s_m' = R_2 / X_2$$

Maximum Torque:

Now we can obtain the magnitude of maximum torque T_{\max} by substituting the value of ' $s_m = R_2 / X_2$ ' in place of ' s ' in the general expression for Torque.

$$T_{\max} = k [s_m E_2^2 R_2 / \{R_2^2 + (s_m X_2)^2\}]$$

$$T_{\max} = k [(R_2 / X_2) E_2^2 R_2 / \{R_2^2 + \{(R_2 / X_2) X_2\}^2\}]$$

Or finally

$T_{\max} = k E_2^2 / 2 X_2$

From the above expression for **Maximum Torque** we can observe the following important points:

- It is directly proportional to the **Square of the induced e.m.f. E_2** in the rotor at stand still.
- It is inversely proportional to the **Rotor Reactance X_2 at stand still**
- The most interesting is : **It is not dependent on the Rotor resistance R_2** . But the slip or speed at which such a maximum Torque occurs depends on the value of **Rotor resistance R_2**

Ratios of Important Torques (In terms of Slip):

These are straightforward calculations. However since these ratios are very important in several problems they are calculated and kept ready for quick use.

Ratio of Full load Torque to Maximum Torque:

$$T = k [s E_2^2 R_2 / R_2^2 + (s X_2)^2]$$

$$T_{fl} = k [s_{fl} E_2^2 R_2 / R_2^2 + (s_{fl} X_2)^2]$$

$$T_{st} = k [E_2^2 R_2 / R_2^2 + (X_2)^2]$$

$$T_{\max} = k [s_m E_2^2 R_2 / R_2^2 + (s_m X_2)^2]$$

$$T_{fl} / T_{max} = k [s_{fl} E_2^2 R_2 / R_2^2 + (s_{fl} X_2)^2] / k [s_m E_2^2 R_2 / R_2^2 + (s_m X_2)^2]$$

$$= (s_{fl} / s_m) [R_2^2 + (s_m X_2)^2] / R_2^2 + (s_{fl} X_2)^2]$$

Dividing both numerator and denominator by X_2^2

$$T_{fl} / T_{max} = (s_{fl} / s_m) [(R_2^2 / X_2^2) + (s_m)^2] / (R_2^2 / X_2^2) + (s_{fl})^2]$$

Substituting s_m in place of (R_2 / X_2)

$$= (s_{fl} / s_m) [(s_m)^2 + (s_m)^2] / [(s_m)^2 + (s_{fl})^2]$$

$$= (s_{fl} / s_m) (2s_m^2) / [(s_m)^2 + (s_{fl})^2]$$

$$T_{fl} / T_{max} = (2s_{fl}s_m) / [(s_m^2) + (s_{fl})^2]$$

Ratio of Starting Torque to Maximum Torque:

$$(T_{st} / T_{max}) = \frac{k [E_2^2 R_2 / R_2^2 + (X_2)^2]}{k [s_m E_2^2 R_2 / R_2^2 + (s_m X_2)^2]}$$

$$= [R_2^2 + (s_m X_2)^2] / s_m [R_2^2 + (X_2)^2]$$

Dividing both numerator and denominator by X_2^2

$$= [(R_2^2 / X_2^2) + (s_m)^2] / s_m [(R_2^2 / X_2^2) + 1]$$

Substituting s_m in place of (R_2 / X_2)

$$(T_{st} / T_{max}) = [(s_m)^2 + (s_m)^2] / s_m [(s_m)^2 + 1] = [2s_m^2] / s_m [(s_m)^2 + 1]$$

$$(T_{st} / T_{max}) = 2s_m / (1 + s_m^2)$$

Torque slip characteristic:

When an Induction motor is loaded from no load to full load its speed decreases and slip increases. Due to increased load, motor has to produce higher torque to satisfy higher load torque demand. The torque ultimately depends on the slip as we have seen earlier. The behavior of the motor can be easily analyzed by looking at the ***Torque versus slip curve from s=0 to 1.*** (Instead of ***Torque versus Speed Characteristics*** because we have readily available equations for Torque in terms of slip 's'. The Torque vs. Slip Characteristics can then be easily translated to Torque vs. Speed Characteristics since they are complementary to each other.)

We have already seen that for a constant supply voltage, E_2 is also constant. So we can rewrite the Torque equation $T \propto \frac{s E_2^2 R_2 / R_2^2 + (sX_2)^2}$ as

$$T \propto \frac{s R_2 / R_2^2 + (sX_2)^2}{} .$$

To study the Torque versus Slip characteristics let us divide the slip range (**s=0 to 1**) into **three** parts and analyze.

The Torque speed characteristic can be divided into three important regions:

1. Low Slip Region:

In this region 's' is very small. So, the term $(sX_2)^2$ in the denominator would be **small** compared to R_2^2 and hence can be neglected. Thus $T \propto s R_2 / R_2^2$. i.e Torque becomes directly proportional to slip 's'. Thus torque increases linearly with increase in **slip 's'** and satisfies the load demand. Thus we can conclude that in this region.

- The mechanical speed decreases approximately linearly with increased load
- The motor slip increases approximately linearly with increased load.
- Induced Torque increases linearly with slip thus satisfying the load demand.
- Rotor reactance is negligible. So Rotor Power factor is almost unity.
- Rotor current increases linearly with slip.

The entire normal steady state operating range of an Induction motor lies in this linear low slip region. Thus in normal operation, an induction motor has a linear speed drooping characteristic.

2. Moderate slip region: In this region:

- Rotor frequency is higher than earlier and hence the Rotor reactance is of the same order of magnitude as the rotor resistance.
- Rotor current no longer increases as rapidly as earlier and the Power factor starts dropping.
- The peak torque (Pull out or Break down Torque) occurs at a point where for an incremental increase in load the increase in the current is exactly balanced by the decrease in rotor power factor.

3. High slip region: In this region:

Slip is high i.e. approaching the value 1. Here it can be assumed that the term R_2^2 is very small compared to $(sX_2)^2$. Hence the expression for Torque becomes $T \propto \frac{R_2}{(sX_2)^2}$ i.e $T \propto 1/s$. So in high slip region Torque is inversely proportional to slip 's'. Hence the induced Torque decreases with increase in load torque since the increase in Rotor current is dominated by the decrease in Rotor power factor where as it should increase to meet the increase in Load demand. So speed further comes down and Induced Torque still reduces further. So in this process the motor comes to standstill i.e. the motor cannot run at any point in the high slip region. Hence this region is called ***unstable region***. On the other hand the low slip region where the characteristic is linear is called the ***stable region***.

The maximum Torque which the motor can produce before going into unstable region occurs at ' $s' = 's_m'$ '. Since beyond this torque the motor gets into unstable region, this maximum Torque is also called as ***Break down Torque*** or ***pullout Torque***. The entire Torque slip characteristics are shown in the figure below.

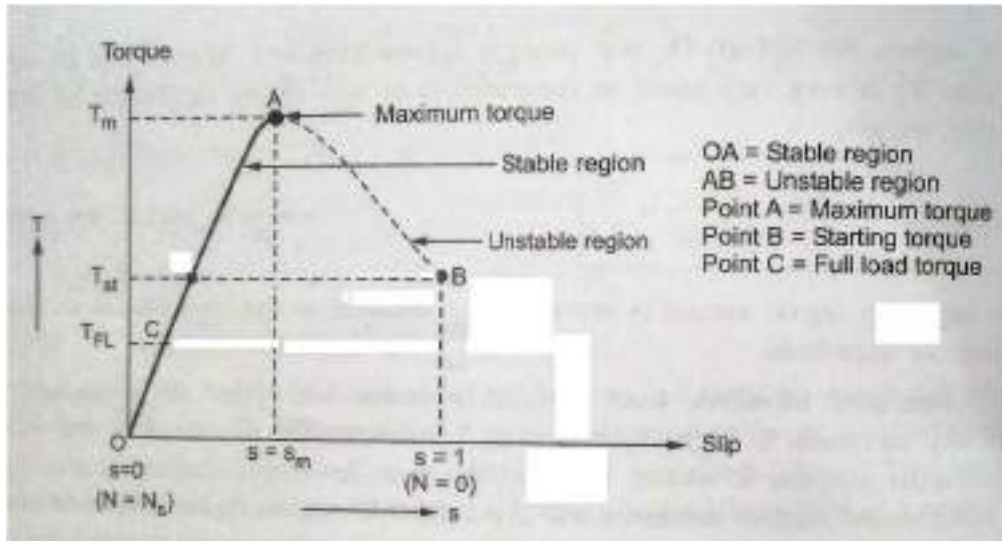

Fig: Torque-slip Characteristics

Torque vs. Speed Characteristics:

They are just complimentary to the Torque-slip Characteristics. The detailed Torque speed characteristics of an a Induction Motor Showing the Starting, Pull-out and Full-load torques are shown in the figure below.

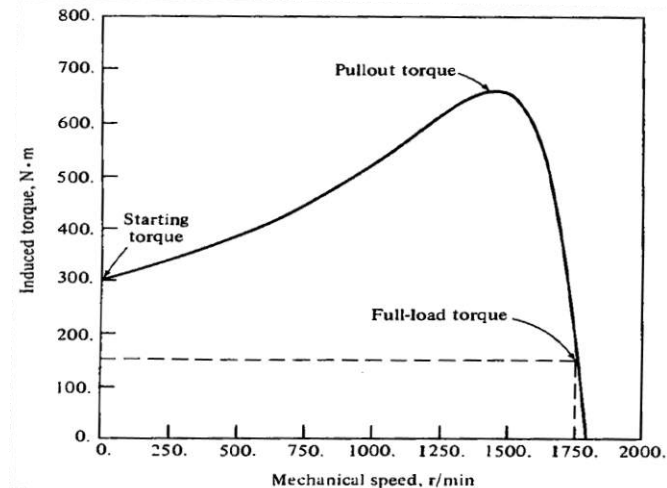

Fig: Torque speed characteristics of an a Induction Motor Showing the Starting, Pull-out and Full-load torques

Important characteristics of the Induction Motor Torque Speed Curve:

- Induced Torque is zero at synchronous speed.
- The graph is nearly linear between no load and full load (at near synchronous speeds). In this region the Rotor resistance is much larger than the Rotor reactance, and hence the Rotor Current, magnetic field and the induced torque increases linearly with increasing slip.
- There is a Max. Possible torque that cannot be exceeded which is known as pull out torque or breakdown torque. This is normally about two to three times the full load torque.
- The Starting torque is higher than the full load torque and is about 1.5 times. Hence this motor can start with any load that it can handle at full power.
- Torque for a given slip varies as the square of the applied voltage. This fact is useful in the motor speed control with variation of Stator Voltage.
- If the rotor were driven faster than synchronous speed, then the direction of the Induced torque would reverse and the motor would work like a generator converting mechanical power to Electrical power.
- If we reverse the direction of the stator magnetic field, the direction of the induced torque in the Rotor with respect to the direction of motor rotation would reverse, would stop the motor rapidly and will try to rotate the motor in the other direction. Reversing the direction of rotation of the magnetic field is just phase reversal and this method of Braking is known as Plugging.

Full load Torque: When the load on the motor Torque increases, the slip increases and thus the Induced torque also increases. The increase in induced Torque is produced by a corresponding increase in the current drawn from the supply.

The load which the motor can drive safely depends on the current which the motor can draw safely. When the current rises, the temperature rises. Hence the safe limit on the current is dictated by permissible temperature rise. ***The safe***

limit of current is that which when drawn for continuous operation of the motor produces a temperature rise which is well within the limits. Such a full load point is shown as point 'C' on the plot and the corresponding torque is called the Full load Torques T_{FL} . If the motor is operated beyond this full load continuously the windings' insulation is likely to be damaged. But for short durations of time the motor can be operated beyond the Full load Torque but up to the limit of **Breakdown Torque/Pull out Torque**

Effect of change in Rotor resistance on Torque:

Earlier we have indicated that in slip ring Induction Motors external Resistance is introduced at the time of starting to get higher Starting Torque and then it is withdrawn in the running condition to get higher efficiency. Let us now see how this is achieved. Let us get back and recollect the most important relation i.e. general expression for Torque T :

$$T = k [s E_2^2 R_2 / R_2^2 + (sX_2)^2]$$

At the time of starting, the **slip = 1** and hence the starting Torque T_{st} becomes:

$$T_{st} = k [E_2^2 R_2 / R_2^2 + (X_2)^2]$$

We have also seen earlier that the maximum Torque T_{max} is given by:

$$T_{max} = KE_2^2 / 2X_2$$

and this Torque occurs at a slip $S_m = R_2 / X_2$

Using these expressions the Torque - slip curves for various values of Rotor resistance greater than the original value R_2 are drawn and shown in the figure below.

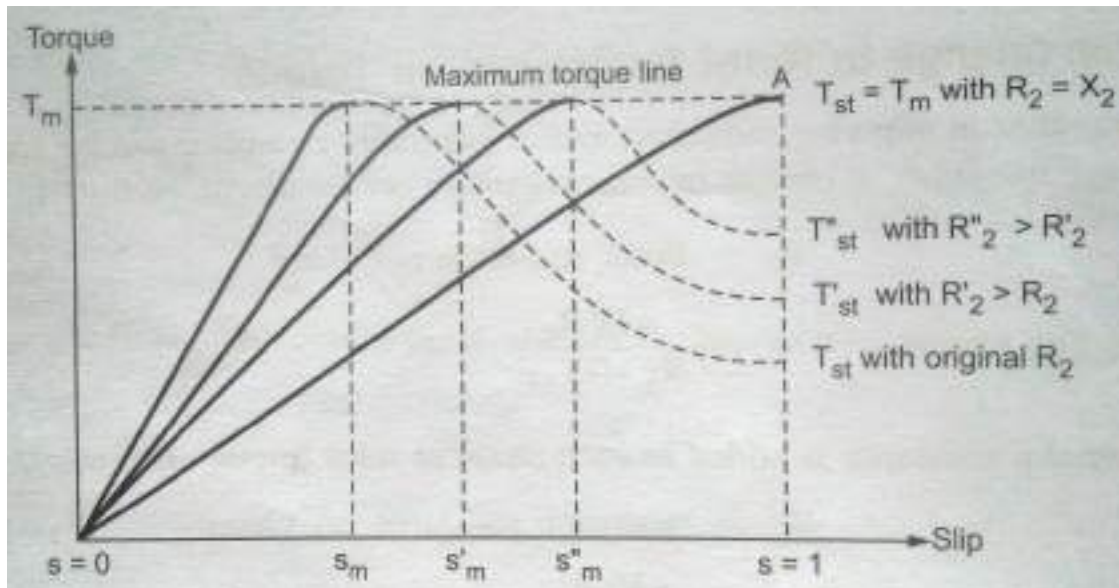

Figure: Effect of change in Rotor resistance on Torque slip characteristics

From these figures and also from the above relations we get the following important observations:

- As the Rotor resistance increases, the slip at which maximum torque occurs increases i.e. the Torque-slip curve moves to the right i.e. towards higher slip with the result the starting torque increases.
- But the other effect is the droop in speed becomes more for the same change in Induced Torque (Load Torque). With higher droop losses are more and hence we get reduced efficiency.
- So to get these both advantages, in Slip ring induction motors resistance is added initially to get higher torque and once the motor picks up speed the resistance is withdrawn to achieve higher efficiency.
- With increasing rotor resistance the maximum starting Torque remains same but the slip at which it occurs only becomes higher.

Equivalent circuit – Phasor diagram:

Equivalent circuit:

The equivalent circuit of an Induction Motor is developed on the same lines as a Transformer with the following nomenclature and as shown in the following figure of an Induction motor depicted as a Transformer.

V_1 = Applied Voltage to the stator /phase

E_1 = Induced Voltage in the stator /phase

E_2 = Induced Voltage in the rotor /phase @standstill

K = Turns ratio = Stator turns/Rotor turns = E_1/E_2

E_{2R} = Induced Voltage in the rotor /phase @running condition

R_1 = Stator Resistance /phase

X_1 = Stator Reactance /phase

R_2 = Rotor Resistance /phase

X_{2R} = Rotor Reactance /phase @running condition

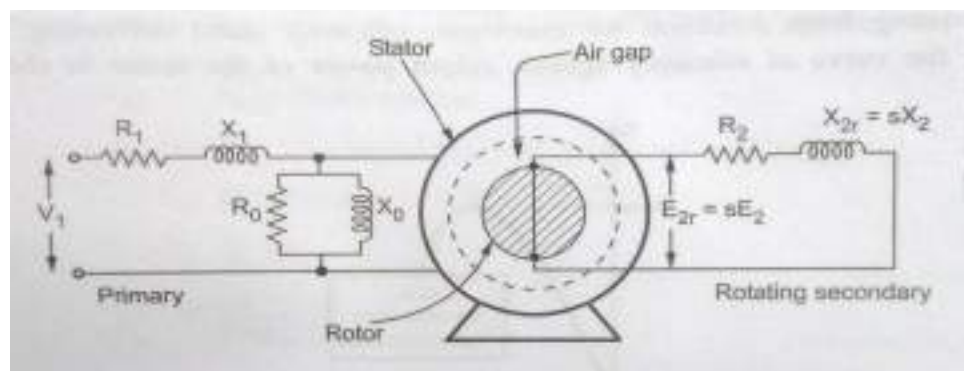

Figure: Induction Motor depicted as a Transformer

Just like in a Transformer the no load current I_0 of an Induction motor has two components I_c and I_m where:

I_c = Active current component which supplies no load losses and

I_m = Magnetizing component which sets up the flux in the core and the air gap.

These two currents give us two elements in the exciting branch R_0 and X_0 as shown in the basic equivalent circuit below.

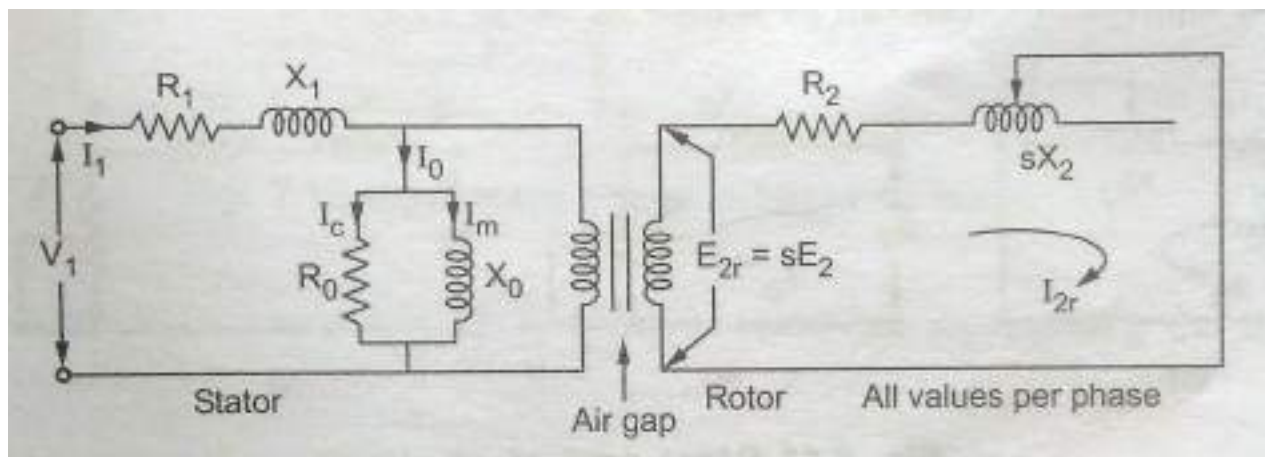

Figure: Induction Motor Basic Equivalent Circuit

The stator and the Rotor are shown separated by an airgap. The rotor current I_{2R} shown in the circuit is given by:

I_{2R} = Rotor current in running condition

= $E_{2R} / Z_{2R} = s E_2 / \sqrt{R_2^2 + (sX_2)^2}$ (@ Running condition which is represented suitably on the rotor side in the equivalent circuit.

Representation of Rotor circuit in different equivalent forms:

We have $I_{2R} = s E_2 / \sqrt{R_2^2 + (sX_2)^2} = E_2 / \sqrt{(R_2/s)^2 + (X_2)^2}$

This other form of equation for I_{2R} indicates that the rotor circuit can be represented equivalently with a fixed voltage E_2 , fixed reactance X_2 and a variable resistance R_2/s . Further (R_2/s) can also be represented as:

$$R_2/s = R_2 + R_2/s - R_2 = R_2 + R_2 [(1/s) - 1] = R_2 + R_2 [(1-s)/s] .$$

This indicates that the variable Rotor resistance can be equivalently represented as two parts:

1. Rotor resistance R_2 itself which represents the copper loss and $R_L = R_2 [(1-s)/s]$ representing the load resistance which is the electrical equivalent of the mechanical load on the motor.

So, the modified equivalent circuit of the Rotor can thus be shown as below:

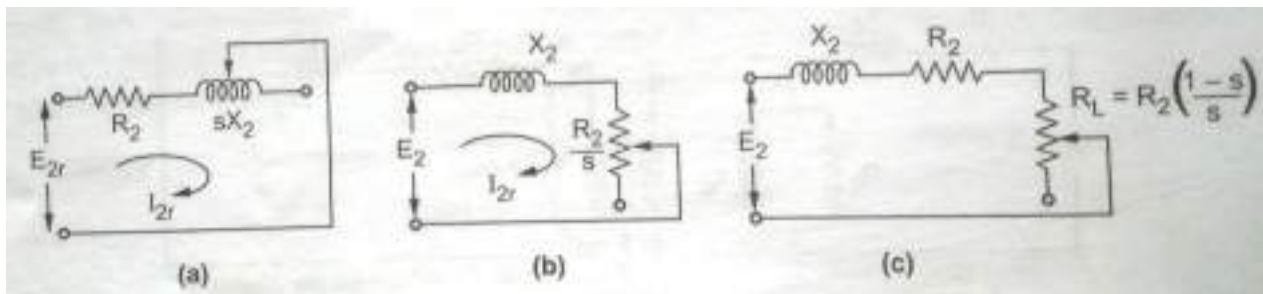

Figure: Modified Rotor Equivalent Circuit

Equivalent circuit referred to Stator: Is shown in the figure below with all the parameters E_2 , I_{2R} , R_2 , and X_2 referred to the stator side and shown with additional “ ‘ ” (prime) as given below.

$$E'_2 = KE_2; I'_{2R} = I_{2R}/K; R'_2 = K^2 R_2; X'_2 = K^2 X_2 \text{ and}$$

$$R'_L = K^2 R_L = K^2 R_2 [(1-s)/s] = R'_2 [(1-s)/s]$$

The equivalent circuit with these changes is shown in the figure below:

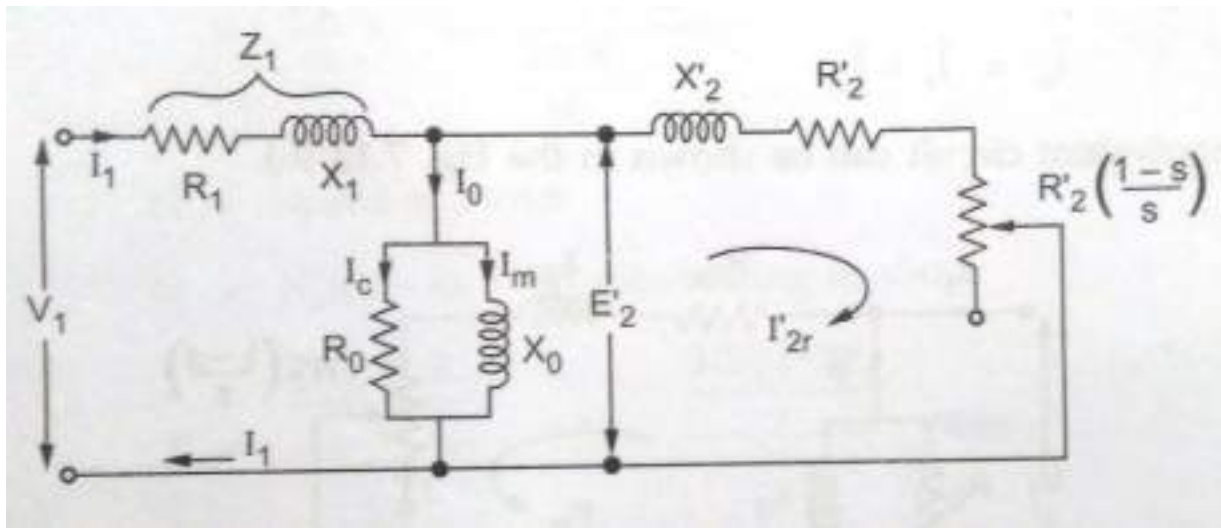

Figure: Total Equivalent circuit referred to Stator

Final Approximate Equivalent circuit referred to Stator: Just like in the case of Transformer, the excitation circuit (R_0 and X_0) can be moved to the input side i.e. to the left of R_1 and X_1 with the assumption that the voltage drop across R_1 and X_1 due to the small current I_0 can be neglected. With this assumption and after combining the R_1 and X_1 with R'_2 and X'_2 we get the final Approximate Equivalent circuit referred to Stator as shown in the figure below with the following final equivalent values of all parameters.

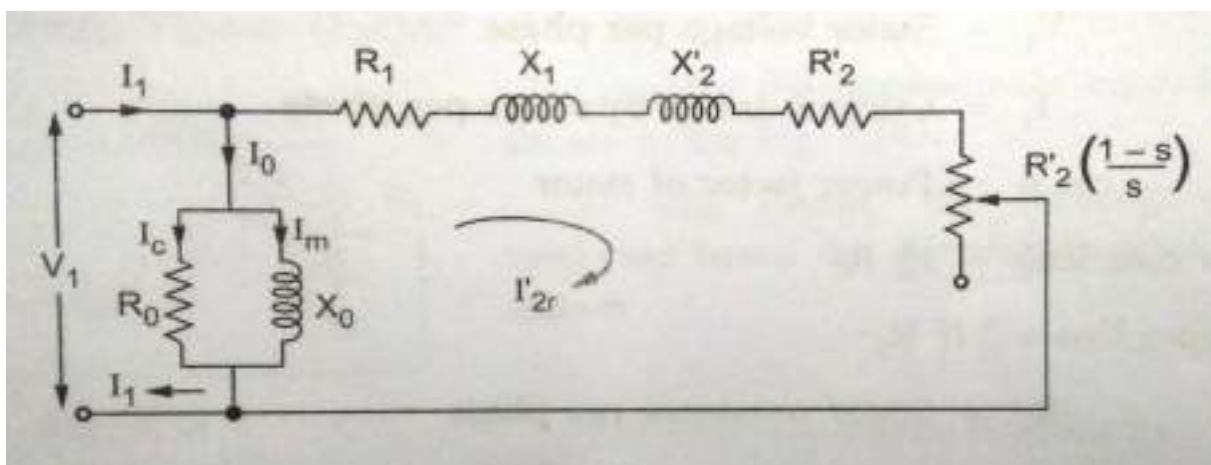

Figure: Final Approximate Equivalent circuit referred to Stator:

R_{1E} = Total equivalent resistance referred to Stator = $R_1 + R'_2 = R_1 + K^2 R_2$

X_{1E} = Total equivalent reactance referred to Stator = $X_1 + X'_2 = X_1 + K^2 X_2$

Phasor diagram:

The Phasor diagram of a loaded Induction Motor is similar to that of a loaded Transformer. The only difference is, the secondary of Induction Motor is rotating and short circuited while a transformer secondary is stationary and connected to a load. The load on Induction Motor is mechanical while the load on a transformer is electrical. So by finding the electrical equivalent of mechanical load on the motor, the phasor diagram of an Induction Motor is developed with the following notation and using the given relations. (All bold faced letters indicate Phasor quantities)

Φ = Magnetic flux linking between Stator and Rotor

E_1 = Self induced e.m.f. in the stator

E_{2R} = Mutually induced e.m.f. in the rotor

R_1 and X_1 = Stator resistance and reactance /phase respectively.

V_1 = Voltage applied to the stator which has to counter balance the induced e.m.f. in the stator E_1 and the voltage drops $I_1 R_1$ and $I_1 X_1$. Hence on the stator side we can write

$$V_1 = -E_1 + I_1(R_1 + jX_1) = -E_1 + I_1 Z_1$$

E_{2R} = The rotor induced e.m.f. in running condition has to supply the drop across the rotor impedance as the rotor is short circuited.

$$= I_{2R} (R_2 + jX_{2R}) = I_{2R} Z_{2R}$$

The rotor current in running condition is I_{2R} and it lags E_{2R} by rotor power factor angle Φ_{2R} .

The rotor current reflected to stator side I'_{2R} is given by $I'_{2R} = I_{2R}/K$ Where $K =$ Stator/Rotor turns ratio. The induction motor draws a no load current of I_0 which is the phasor sum of core loss current I_c and magnetizing current I_M . Thus the total current I_1 drawn by the stator is the phasor sum of I'_{2R} and I_0 and is given by:

$$I_1 = I'_{2R} + I_0$$

$\Phi_1 =$ Phase angle between V_1 and I_1 and hence $\cos \Phi_1$ is power factor of the Induction Motor.

Using all the above relations and the notation the phasor diagram is developed in the following steps:

- Take Φ as the reference phasor
- The induced voltage E_1 lags Φ by 90°
- Show $-E_1$ by reversing the voltage phasor E_1
- The phasor E_{2R} is in phase with E_1 . So show I_{2R} lagging E_{2R} i.e. E_1 direction by Φ_{2R}
- Show $I_{2R}R_2$ in phase with I_{2R} and $I_{2R}X_{2R}$ leading the resistive drop by 90° , to get exact location of E_{2R}
- Reverse I_{2R} to get I'_{2R}
- I_M is in phase with Φ while I_c is at 90° leading with Φ . Add I_M and I_c to get I_0
- Add I_0 and I'_{2R} to get I_1
- From tip of $-E_1$ phasor add I_1R_1 in phase with I_1 and I_1X_1 at 90° leading to I_1 to get V_1 Phasor.
- Angle between V_1 and I_1 is Φ_1

The phasor diagram is shown in the figure below.

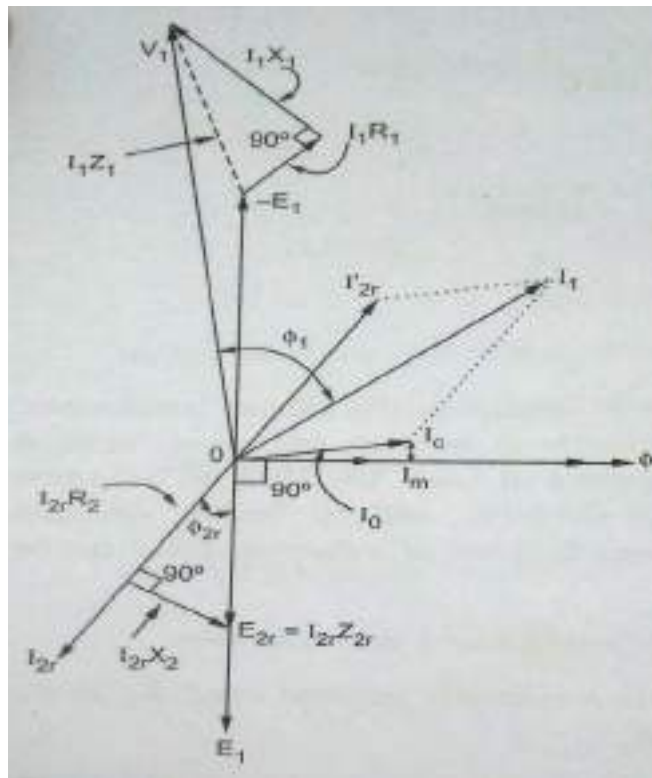

Power and Torque in an Induction Motor: (In terms of slip's' and equivalent circuit parameters)

In the power flow diagram we have already studied broadly the power and torque relations. Now with the development of the motor equivalent circuit we have a better insight into these relations including the important term slip's'. Accordingly we will redefine the power flow in terms of slip's' and equivalent circuit parameters. This approach is essential to solve many problems. For quick reference Power flow diagram and the Rotor side equivalent circuits are appended here again.

The stator copper losses in the 3 phases are: $P_{SCL} = 3 I_1^2 R_1$

The core losses are: $P_{Core} = 3 E_1^2 / R_0$

And the air gap power is: $P_{AG} = P_{in} - P_{SCL} - P_{core}$

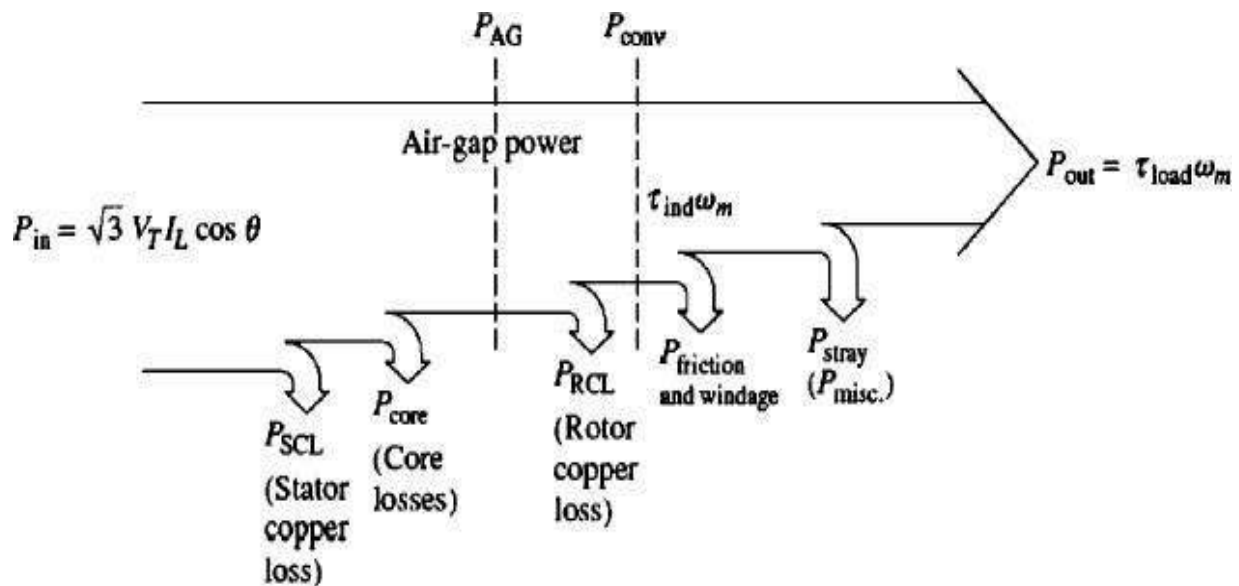

Figure: Power Flow Diagram

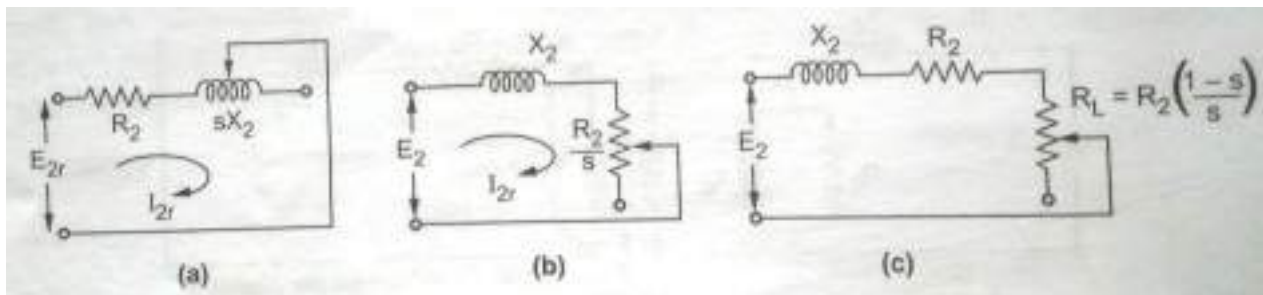

Figure: Modified Rotor Equivalent Circuit

In the above equation it is to be noted that P_{core} combines both stator and rotor core losses which can be acceptable since Rotor core losses are very small compared to the rotor copper losses. It is also to be remembered that the only element in the equivalent circuit where the air-gap power can be subsequently consumed [(lost + used as output power (used to drive the load))] is in the resistor R_2/s . Thus, the air-gap power is given by:

$$P_{AG} = 3I_{2R}^2 R_2 / s = T_{ind} \cdot \omega_s \quad \dots (1)$$

The actual Rotor copper losses are given by: $P_{RCL} = 3I_{2R}^2 R_2 \quad \dots (2)$

[I_{2R} is the rotor current (running condition) and R_2 is the Rotor resistance before referring to stator] **From the above two equations (1) and (2) we notice that the rotor copper losses are equal to slip times the air gap power i.e. $P_{RCL} = s \cdot P_{AG}$..(1)**

After stator copper losses & core losses are subtracted from the input power we got the Air gap power from which rotor copper losses are subtracted, to get the remaining power which is converted from electrical to mechanical form. The power thus converted, which is called developed (converted) mechanical power is given as: [from equations (1) and 2)]

$$P_{conv} = P_{AG} - P_{RCL} = 3I_{2R}^2 \cdot R_2 / s - 3I_{2R}^2 R_2 = 3I_{2R}^2 R_2 [(1/s) - 1]$$

$$= 3I_{2R}^2 (R_2 / s)(1 - s) = T_{ind} \cdot \omega_m$$

Thus finally $P_{conv} = P_{AG} (1 - s) = T_{ind} \cdot \omega_m \dots\dots (2)$

If we carefully observe the above equations 1 and 2 we can notice that the three important equations P_{AG} , P_{RCL} and P_{CONV} are in the ratio of 1: s: (1-s). This relation is very useful in solving several problems.

Summary:

Important formulae and relations:

- Synchronous speed of rotating magnetic field : $n_s = 120 \cdot f_s / P$
- Torque induced in the rotor: $T_a = \phi \cdot I_{2r} \cdot \cos \theta_{2r}$ or $T = k \phi \cdot I_{2r} \cdot \cos \theta_{2r}$
- slip s on percentage basis:

$$s = \frac{n_{slip}}{n_{sync}} (\times 100\%) = \frac{n_{sync} - n_m}{n_{sync}} (\times 100\%)$$

- Slip s on per unit basis: $S = (N_{sync} - N_m) / N_{sync}$
- The magnitude of the rotor induced voltage E_{2R} in terms of the rotor induced voltage at rotor in locked condition E_2 : $E_{2R} = s \cdot E_2$
- The magnitude of the rotor Reactance X_{2R} in terms of the rotor Reactance at rotor locked condition X_2 : $X_{2R} = s \cdot X_2$ (since $f_r = s \cdot f_s$ and $X_{2R} = s \cdot 2\pi f_s L_R$)

- The rotor frequency can be expressed as :

$$f_r = (P/120) \cdot (n_{\text{sync}} - n_m)$$

- Important relationships between Air gap power P_{AG} , converted power P_{conv} , Rotor induced Torque T_{ind} , Rotor copper losses P_{rcl} and the slip s :

$$T_{\text{ind}} = P_{\text{conv}} / \omega_m$$

$$T_{\text{ind}} = P_{AG} / \omega_s$$

$$P_{\text{rcl}} = s \cdot P_{AG}$$

$$P_{\text{conv}} = (1-s) P_{AG}$$

- Induced Torque T_{ind} :
$$T_{\text{ind}} = (k E_2^2 R_2) [s / R_2^2 + s^2 X_2^2]$$
- Slip at maximum Torque $s_{\text{maxT}} = R_2 / X_2$

Maximum developed torque $T_{\text{max}} = k E_2^2 / 2 X_2$

$$\text{Starting Torque } T_{\text{st}} : \quad T_{\text{st}} = k [E_2^2 R_2 / R_2^2 + X_2^2] \quad \text{N-m}$$

Illustrative Problems:

Example 1: In a 6 pole, 3 phase, 50 Hz Induction motor with star connected Rotor, the rotor resistance per phase is 0.3Ω , the reactance at standstill is 1.5Ω per phase and the e.m.f between the slip rings on open circuit is 175 V. Calculate: (i) Slip at a speed of 960 RPM (ii) Rotor e.m.f per phase (iii) Rotor frequency and reactance at speed of 950 RPM

Solution: Given data: $R_2 = 0.3 \Omega$, $X_2 = 1.5 \Omega$, $P = 6$, $f = 50 \text{ Hz}$, $E_2(\text{line @standstill}) = 175 \text{ V}$

$$E_{2\text{ph}} = 175 / \sqrt{3} = 101.0362 \text{ V (@ standstill)}$$

- i) Synchronous speed $N_s = 120f/P = 120 \times 50 / 6 = 1000 \text{ RPM}$.

Slip 's' @960 RPM = $(N_s - N) / N_s = (1000 - 960) / 1000 = \mathbf{0.04 \text{ i.e. } 4\%}$

ii) Rotor e.m.f. per phase at the speed of 960RPM = $E_{2r} = s E_{2ph}$

$$= 0.04 \times 101.362 = \mathbf{4.0414 \text{ V}}$$

iii) For N = 950 RPM , slip 's' = $(1000 - 950) / 1000 = \mathbf{0.05}$

Rotor frequency $f_r = s f = 0.05 \times 50 = \mathbf{2.5 \text{ Hz}}$

$$X_{2r} = s X_2 = 0.05 \times 1.5 = \mathbf{0.075 \Omega}$$

Practice example: A 3 ϕ , 50 Hz slipring Induction Motor gives a stand still open circuit voltage of 500 V between slip rings. Calculate the rotor current and power factor at (i) standstill and (ii) with a slip of 4%. The per phase rotor resistance and Inductance are 0.2 Ω and 0.04 H .

Example 2: A- 6-pole, 50Hz, 3-phase, induction motor running on full load with 4% slip develops a torque of 149.3 N-m at its pulley rim. The friction and wind age losses are 200 W and the stator copper and iron losses equal 1620 W. Calculate:

(i) Output power (ii) Rotor cu loss and (iii) The efficiency at full-load.

Solution: Torque at pulley rim means final torque out put at the shaft end and hence $T_{sh} = 149.3 \text{ Nm}$, Number of poles $P = 6$, $f = 50 \text{ Hz}$, $s = 4 \%$ i.e. 0.04

i) Synchronous speed $N_s = 120f/P = 120 \times 50/6 = 1000 \text{ r.p.m}$

And Motor speed $N = N_s (1-s) = 1000 (1-0.04) = 960 \text{ r.p.m}$

$$P_{out} = T_{sh} \times \omega \text{ (Motor speed in Rad/sec)} = T_{sh} \times 2\pi N / 60 = \mathbf{15009.273 \text{ W}}$$

ii) Torque developed by the motor:

$$P_m = P_{out} + \text{Friction loss} = 15009.273 + 200 = \mathbf{15209.273 \text{ W}}$$

From the power flow diagram we know that: $P_{AG} : P_{cL} : P_m$ is $1 : s : 1 - s$

$$P_m / P_c = 1 - s / s \text{ i.e. } P_c = s P_m / (1 - s) = 0.04 \times 15209.273 / (1 - 0.04) = \mathbf{633.7197 \text{ W}}$$

iii) $P_{AG} = P_m + P_c = 15209.273 + 633.7197 = 15842.9927 \text{ W}$

$$\therefore P_{in} = P_{AG} + \text{Stator loss} = 15842.9927 + 1620 = 17462.9927 \text{ W}$$

$$\therefore \% \eta = (P_{out} / P_{in}) \times 100 = (15009.273 / 17462.9927) \times 100 = \mathbf{85.949 \%}$$

Example 3: The power input to the rotor of a 440 V, 50 Hz 6-pole, 3-phase induction motor is 80 kW. The rotor emf is observed to make 100 complete alteration per minute.

Calculate : (i) The slip (ii) The rotor speed (iii) Rotor copper losses per phase.

Solution : Power input to rotor = $P_2 = 80 \text{ kW}$, $P = 6$, $f = 50 \text{ Hz}$, $f_r = 100$ alterations per min = $100/60 \text{ Hz} = 1.667 \text{ Hz}$.

i) We know that the frequency of the Rotor Induced frequency $f_r = s f$. Thus slip ' s ' = $f_r / f = 1.667/50 = \mathbf{0.0333}$

ii) Motor synchronous speed $N_s = 120 f / P = (120 \times 50) / 6 = 1000 \text{ RPM}$

ii) Motor(Rotor) speed $N = N_s (1 - s) = 1000 \times (1 - 0.0333) = \mathbf{966.667 \text{ r.p.m}}$

iii) We know that the ratio: $P_{AG} : P_{CL} : P_m$ is equal $1 : s : 1 - s$

i.e. Rotor copper Losses $P_c = s P_{AG} = (0.0333) \times 80,000 = 2666.64 \text{ W}$

\therefore Rotor copper Losses per phase = $P_{CL} \text{ Per Phase} = 2666.4/3 = \mathbf{888.888 \text{ W}}$

Example 4: The power input to a 500 V, 50 Hz, 6-pole, 3-Phase induction motor running at 975 rpm is 40 kW. The stator losses are 1 kW and the friction and windage losses total to 2 kW, Calculate: i)The slip ii) Rotor copper loss and iii) Shaft power

Solution: Given data: $P_{in} = 40 \text{ kW}$, $f = 50 \text{ Hz}$, $P = 6$, $N = 975 \text{ r.p.m}$, Stator Loss = 1kW, Friction and windage loss = **2kW**

i) Motor synchronous speed $N_s = 120f/P = (120 \times 50) / 6 = 1000 \text{ RPM}$

We know that the slip ' s ' = $N_s - N / N_s = (1000 - 975) / 100 = \mathbf{0.025 \text{ i.e. } 2.5\%}$

ii) We know that the Air gap power $P_{AG} = P_{in} - \text{Stator losses} = 40 - 1 = \mathbf{39 \text{ kW}}$

We know that the ratio: $P_{AG} : P_{CL} : P_M$ is $1 : s : 1 - s$ i.e. $P_{AG} / P_{CL} = 1/s$

∴ Rotor copper loss : $P_c = s P_{AG} = 0.025 \times 39 = \mathbf{0.975 \text{ kW}}$

iii) Power developed by motor: $P_m = P_{AG} - P_c = \mathbf{39 - 0.975 = 38.025 \text{ kW}}$

∴ Finally Shaft power = Output Power P_{out}

$$= P_m - \text{Frictional losses} = \mathbf{38.025 - 2 = 36.025 \text{ kW}}$$

Example 5: A 10 Kw, 400 V, 3- Phase induction motor has full load efficiency of 0.87 and power factor 0.85. At standstill at rated voltage the motor draws 5 times full load current and develops a starting torque of 1.5 times full load torque. An autotransformer is installed to reduce the starting current to give full load torque at the time of starting. Calculate the voltage applied and line current.

Solution:

From the given data first we can calculate directly the full load current I_{FL} . Using the straight forward formula.

$$I_{fl} = P_{out} / (\sqrt{3} V_L \cos \phi \times \eta) = 10 \times 10^3 / (\sqrt{3} \times 400 \times 0.85 \times 0.87) \\ = \mathbf{19.5182 \text{ A}}$$

Then let us use the standard Torque relation 'Torque is proportional to the square of the voltage' to calculate the reduced voltage to get starting Torque equal to FL Torque.

$$T_{st1} = 1.5 T_{fl} \propto (400)^2$$

$$T_{st2} = T_{fl} \propto (V_2)^2$$

$$\therefore T_{st1} / T_{st2} = 1.5 T_{fl} / T_{fl} = (400 / V_2)^2$$

$$\therefore V_2 = 400 / \sqrt{1.5} = \mathbf{326.6 \text{ V}}$$

For 400 V, $I_{st1} = 5 I_{fl}$

Then for 326.6 V, $I_{st2} = 5 I_{fl} \times 326.6 / 400 = 4.0825 I_{fl}$

$$\therefore I_{st2} = 4.0825 \times 19.5182 = \mathbf{79.6833 \text{ A}}$$

On the autotransformer secondary, motor current is 79.6833 A and secondary voltage is 326.6 V.

$$\therefore I_{primary} = (326.6 / 400) \times 79.6833 = 65.0614 \text{ A}$$

$$\therefore \text{Line current} = \mathbf{65.0614 \text{ A}}$$

Example 6 : A 3 ϕ slip ring IM with a synchronous speed of 1500 r.p.m. develops 4 HP at 1410 r.p.m. Calculate the stator input, if the stator power loss is 500 W. If a resistance is inserted in the rotor circuit so that the mechanical power is 5 HP at 1125 r.p.m then calculate the stator input assuming the stator losses to be 150 % of the previous value.

Solution : From Given Data we have : $N_s = 1500$ RPM, $P_{m1} = 4$ HP at $N_1 = 1410$ r.p.m, $P_{m2} = 5$ HP at $N_2 = 1125$ r.p.m.

From the standard ratio of powers and loss we have : $P_{AG} : P_{CL} : P_m$ is $1 : s : 1 - s$

$$\text{Hence } P_{AG}/P_m = 1/(1 - s)$$

Applying this relation to the two cases we have, we get

Case 1: $s_1 = (N_s - N_1)/N_s = [(1500 - 1410)/1500 = 0.06$

$$(P_{AG})_1/P_{m1} = 1/(1 - s_1)$$

i.e. $(P_{AG})_1 = P_{m1} [1/(1 - s_1)] = (4 \times 735.5)/(1 - 0.06) = 3129.7872$ W

\therefore (Stator input) $_1 = (P_{AG})_1 + \text{Stator loss} = 3129.7872 + 500 = \mathbf{3629.79}$ W

Case 2: $s_2 = (N_s - N_2) / N_s = (1500 - 1125) / 1500 = 0.25$

$$(P_{AG})_2/P_{m2} = 1/(1 - s_2)$$

\therefore $(P_{AG})_2 = P_{m2}[1/(1 - s_1)] = (5 \times 735.5)/(1 - 0.25) = 4903.333$ W

Stator loss = 150 % of 500 W = 750 W

\therefore (Stator input) $_2 = 4903.333 + 750 = \mathbf{5653.333}$ W

Example 7: A-3 Phase wound rotor of induction motor develops a maximum torque of 4 times the full load torque at a slip of 0.20. The per phase rotor resistance is 0.04Ω . The stator resistance and rotational losses are negligible. Calculate the value of external resistance that must be inserted in the rotor circuit in order to maximize torque at starting.

Solution: $T_m = 4T_{fl}$, $s_m = 0.2$, $R_2 = 0.04$ (where T_m is maximum Torque and S_m is the Slip at maximum Torque)

We know that $s_m = R_2/X_2$ i.e $X_2 = 0.04/0.2 = 0.2$

We have the standard formula: $T_{fl}/T_m = 2S_{fl} \times S_m / (S_{fl}^2 + S_m^2)$ (where T_{fl} and S_{fl} are Torque and slip at full load.)

$$\therefore \frac{1}{4} = 2s_{fl} \times 0.2 / (0.2)^2 + S_{fl}^2$$

Simplifying and solving we get $S_{fl}^2 - 1.6.S_{fl} + 0.4 = 0$ i.e. $s_{fl} = 1.574, 0.025$

$\therefore s_{fl} = 0.025$ i.e. 2.5 % (Since slip cannot be higher than 1)

We know that $T_{st} \propto E_2^2 R_2 / (R_2^2 + X_2^2)$ and $T_m \propto s_m E_2^2 R_2 / [R_2^2 + (s_m X_2)^2]$

But at start: $R'_2 = R_2 + R_{ex}$ (With External resistance added)

and $T_{st} = T_m$ (To maximize torque)

$$\therefore T_{st}/T_m = 1 = E_2^2 R'_2 / [(R'_2)^2 + (X_2)^2] \times [R_2^2 + (s_m X_2)^2] / s_m E_2^2 R_2$$

$$\text{i.e. } 1 = R'_2 / [(R'_2)^2 + (0.2)^2] \times [(0.04)^2 + (0.2 \times 0.2)^2] / 0.2 \times 0.04$$

Simplifying we get : $(R'_2)^2 - 0.4 R'_2 + 0.04 = 0$ i.e. $R'_2 = 0.2, 1$

$\therefore R'_2 = 0.2 \Omega$ (Neglecting higher value since we need to find out the minimum resistance to be added)

$$\therefore R_{ex} = R'_2 - R_2 = 0.2 - 0.04 = \mathbf{0.16 \Omega}$$

Important Questions:

1. Explain briefly the constructional features of (i) Squirrel cage Induction Motors (ii) Slip ring Induction Motors with the help of suitable figures.
2. Describe with the help of suitable figures and all relevant equations how a Rotating Magnetic field is generated by a set of three phase voltages.
3. Explain briefly the Principle of operation of an induction Motor & the development of Induced Torque in an Induction Motor.

4.(a) Explain the concept of slip in an Induction Motor (b) Derive expressions for (i) Rotor induced emf E_2 (ii) Rotor Induced frequency f_R (iii) Rotor reactance X_2 (iii) rotor current I_2 and (iv) Power factor at standstill and during operation: (Effect of Slip on Rotor parameters) with the help of Impedance triangles. (c) Using the above parameters draw the Rotor equivalent circuits @ Standstill and in running condition.

5. Explain clearly the relationship between Rotor power input, Rotor copper loss, other important losses and final mechanical power developed with the help of a power flow diagram and appropriate equations.

6. (a) Explaining clearly the underlying principles derive an expression for the Torque induced in a an Induction motor. (b) Derive the condition for the maximum developed Torque. Using this condition derive the expression for the maximum Torque. (c) Using these relations derive simplified expressions in terms of *slip* at various conditions for the important torque ratios:

(i) T_{fl} / T_{max} (ii) (T_{st} / T_{max})

7. (a) Using the basic Torque equation of an Induction Motor explain the dependence of Torque on slip in the three important regions and thus draw the Torque slip characteristic. (b) Explain the terms Starting Torque, Maximum Torque and Full Load torque with reference to the Torque – Slip Characteristics.

8. (a) Draw and Explain how Torque - speed characteristic can be obtained from the Torque - Slip Characteristic. (b) Explain the important performance characteristics of the Induction Motor from the Torque Speed Curve

9. (a) Starting from the first principles ,step by step develop the equivalent circuit in the final simplified form with Rotor referred to Stator side.

(b) Explain what is Phasor diagram and draw the Phasor diagram of the Induction motor with reference to the above equivalent circuit.

XXXXXXXX

UNIT-II

INDUCTION MOTORS: TESTING, STARTING & SPEED CONTROL METHODS

- Determination of Efficiency
- No load and blocked rotor tests
- Predetermination of performance
- Methods of starting and starting current & torque calculations.
- Speed Control: Change of frequency, Change of poles & method of consequent poles
- Cascade connection
- Injection of an e.m.f into rotor circuit (qualitative treatment only)
- Induction generator - principle of operation
 - Illustrative Problems
 - Important questions

Determination of Efficiency:

Efficiency of an induction motor can be determined by directly loading the motor and by measuring its input and output power. Small motors can be conveniently tested by this direct method. For motors of higher ratings, however, it may be difficult to arrange loads for the motor in the testing laboratory. Even if load is arranged there will be heavy power loss in the testing process. In order to avoid the wastage of power, indirect methods are used for determining efficiency.

In an indirect method of determining efficiency, various losses of the motor are determined. For determining the various losses in an induction motor, two tests, similar to those conducted on transformers, are performed on the motor. They are: (a) no-load test and (b) blocked-rotor test.

No-load Test:

In no-load test, without connecting any load on the motor shaft, full voltage is applied across the stator winding terminals. Since output of the motor at no-load is zero, the whole input power is consumed as various losses. At no-load, the speed of the rotor is almost equal to synchronous speed. Hence Slip “ s ” is very small and the e.m.f induced in the rotor & the resulting rotor current both are negligibly small. The rotor can, therefore, be approximately considered as an open circuit. No-load test of an induction motor is therefore, similar to no-load test on a transformer. The losses at no-load are:

- (a) I^2R loss in the stator winding;
- (b) Core losses in the stator and rotor;
- (c) Friction and windage losses.

No-load current drawn by an induction motor is much higher than that of a transformer since losses mentioned in (a) and (c) above will not be present in transformer. Therefore, No load losses in Induction motor cannot be assumed as negligible and will consist of both constant losses (core losses plus friction & windage losses) and also Variable losses (***Total I^2R losses where ‘R’ is the total equivalent resistance of Stator and Rotor referred to Stator***). From the total input at no-load, these I^2R -losses are to be subtracted to get constant losses i.e. core losses plus friction & windage losses. Both these losses at no-load are nearly the same as those that would occur under full-load condition and hence are considered as ***constant losses***. This is because:

- (i) Core loss depends on applied voltage which would be constant (Same on no load and Full load)
- (ii) Friction and windage losses depend upon speed of rotation of the rotor and the variation of speed of an induction motor from no-load to full-load is negligibly small.

Connection diagram for no-load test on an induction motor is shown in the figure below.

The sum of the two wattmeter readings ($W_1 + W_2$) gives the no-load input power to the motor. Subtracting the ' I^2R loss' at no load from the input power we get the constant losses (core losses plus the friction & windage losses).

So to get '*stator I^2R loss*' we need current at no load ' I_{NL} ' and Stator resistance ' R '. Out of these two ' I_{NL} ' is available from any of the ammeter readings and stator resistance ' R ' has to be obtained from the next test viz **Blocked Rotor Test(or full Load test)**

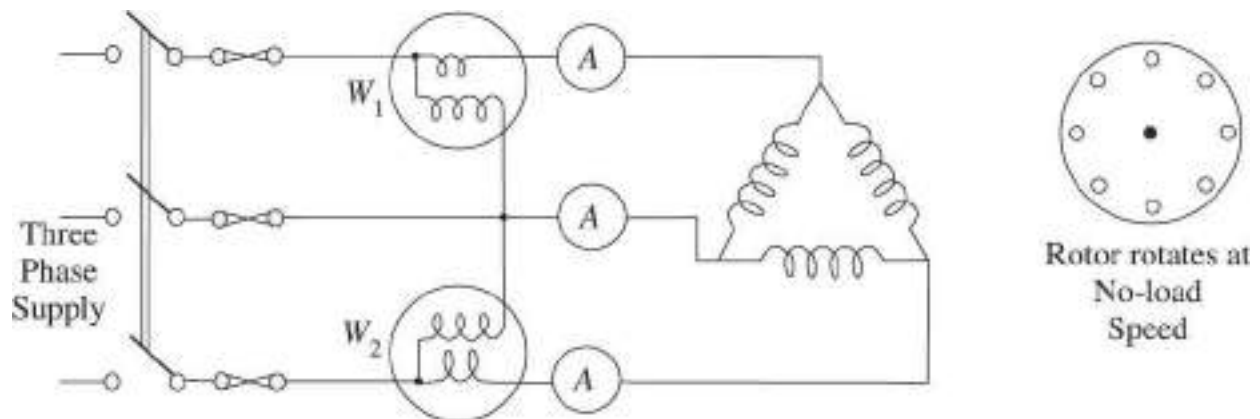

Figure: No-load test on an induction motor

Blocked Rotor Test: In this test, the rotor of the motor is blocked, i.e., the rotor is not allowed to rotate. Low voltage is applied across the stator terminals through a three-phase autotransformer. Voltage is gradually increased to a value so that full rated current flows through the windings. Since the rotor circuit is closed and is not rotating, this test is similar to short-circuit test on a transformer. The voltage needed to circulate full load (rated) current under blocked rotor condition is very

low. The power input to the stator is mainly wasted as I^2R -loss in the stator and the rotor windings. The core-loss at reduced voltage can be neglected. The circuit diagram for blocked rotor test is given in the figure below.

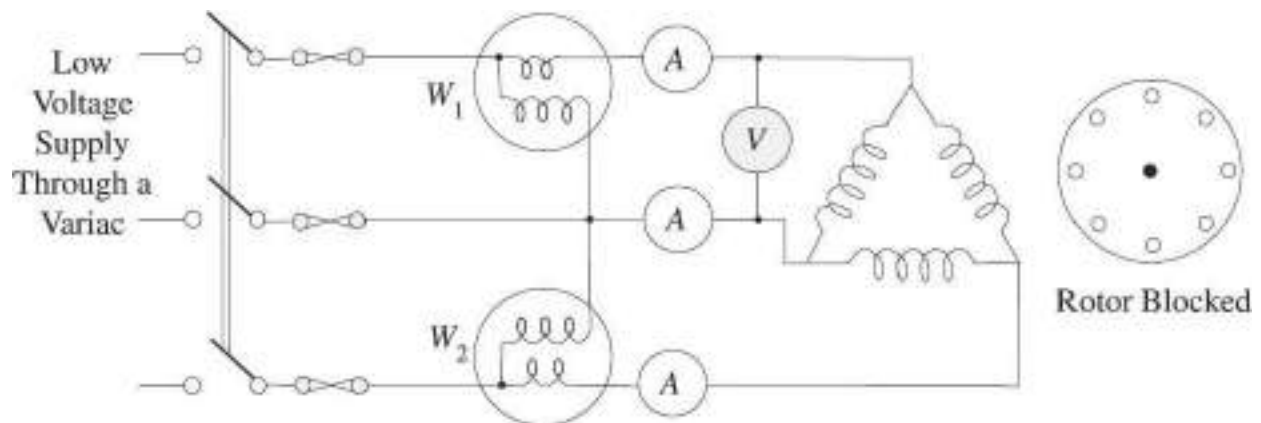

Figure: Blocked-rotor test on an induction motor

The sum of the two wattmeter readings gives the total input power. Since full-load current is allowed to flow through the stator and rotor windings, the input power can be considered approximately equal to full-load I^2R -losses. From the input power it is possible to calculate the total equivalent resistance of the motor referred to the stator (resistance of Stator and Resistance of Rotor referred to the stator side)

Using the value of this total **equivalent resistance** which would be same on no load and on full load, we can calculate the value of I^2R -loss at no load.

As mentioned earlier, if we subtract I^2R -loss at no-load from the no-load input power obtained from no-load test, we get the constant losses of the induction motor.

From the data of the no-load and blocked-rotor tests, therefore, it is possible to calculate the efficiency of the induction motor. For better understanding, the procedure for calculation of efficiency from no-load and blocked rotor test data is also explained with the help of the example below.

Example: A 4-pole, 50 Hz, 230 V, 5 hp squirrel-cage induction motor gave the following test data:

No-load test: Power input (on No load) = 275 W; No-load current = 6.3 A; No-load input voltage = 230 V

Blocked-rotor test: Power input = 735 W; Blocked rotor full-load current = 15 A
Blocked rotor input voltage = 40 V

Determine the full-load efficiency of the motor from the above test data.

Solution:

Step 1: We will calculate the equivalent resistance of stator plus rotor referred to stator R_e' from the **Blocked rotor test data:**

Neglecting the small amount of core-loss (since the applied input voltage is small under blocked-rotor condition, the input to the motor in blocked rotor test can be taken as the full-load copper (I^2R) losses.

Power input from blocked rotor test = Full-load ($I_{FL}^2 R_e'$) losses = 735 W = $3 I_{FL}^2 R_e'$
where R_e' is the per phase equivalent resistance of the Stator plus rotor windings referred to stator circuit.

Thus $3 I_{FL}^2 R_e' = 3 \times 15^2 \times R_e' = 735$

From which we get $R_e' = 735 / (3 \times 15^2) = 1.09 \Omega$

Step 2: Using this equivalent resistance which is same in both no load and full load condition we will calculate no-load I^2R -losses and then the constant losses (core losses plus friction & windage losses) from the **No load test data:**

Input power at no-load gives the core-losses plus friction & windage losses (constant losses) in addition to no-load I^2R -losses. Now by using the value of R_e' obtained from Blocked rotor test I^2R -loss at no-load can be calculated.

I^2R -loss at no-load = $3 I_{NL}^2 R_e' = 3 \times (6.3)^2 \times 1.09 = 130$ W

Constant losses (Core loss plus friction & windage loss) = Power input in no load test ($P_{IP NL}$) - I^2R -loss at no-load ($3 I_{NL}^2 R_e'$)

$$= 275 - 130 = 145 \text{ W}$$

Step 3: Thus total losses at full load = Full load copper losses (Power input in Blocked rotor test) + Constant losses obtained as above in step 2.

$$= 735 + 145 = 880 \text{ W}$$

Output power = 5 Hp = 5x735.5 W

Hence Efficiency @FL=[(Output power)/ ((Output power + Losses @FL)) x100

$$= [(5 \times 735.5) / (5 \times 735.5 + 880)] \times 100 = 80.7 \%$$

Methods of starting and starting current & Torque calculations:

Introduction to Starting and Necessity of a Starter:

An induction motor is similar to a poly-phase transformer whose secondary is short circuited. Thus, at normal supply voltage, like in transformers, the initial current taken by the primary is very large for a short while. If an induction motor is directly switched on from the supply, it takes 5 to 7 times its full load current and develops a torque which is only 1.5 to 2.5 times the full load torque. This large starting current produces a large voltage drop in the line, which may affect the operation of other devices connected to the same line. Further, the resulting increase in temperature of the windings can damage the windings and their insulation. Hence, it is not advisable to start induction motors of higher ratings (generally above 5HP) directly from the mains supply.

The starter is basically a device to limit the high starting current since the input current is dependent on the applied voltage as given by the following relation.

$$I_{2r} = E_{2r} / Z_{2r} = E_{2r} / \sqrt{R_2^2 + j X_{2r}^2} = s E_2 / \sqrt{R_2^2 + (sX_2)^2} \quad (@ \text{ Running condition })$$

But at the start, the speed of the motor is zero and the slip's' is maximum i.e. unity. So the magnitude of the induced voltage at the start is very large. Since the rotor conductors are short circuited, this large induced e.m.f. circulates large rotor currents at the time of 'start'.

Hence by reducing the input voltage, the starting current can be limited to a safe value.

In addition to limiting the starting current, a starter provides protection to the motor against fault conditions such as over load, under voltage, and single phasing. There are several types of Starters performing these basic functions and their principle of operation is explained below.

Types of Starters:

From the above expression for current we can see that the current can be reduced by reducing the induced voltage E_2 (in turn by reducing the applied voltage V_1) or by increasing the Rotor resistance R_2 at start. The second method is possible only in the case of Slip ring Induction Motors. The various types of starters using the above two basic methods are listed below and explained in detail subsequently.

1)Stator Resistance Starter 2)Auto Transformer Starter 3)Star-Delta Starter
4)Rotor Resistance Starter 5)Direct On Line (DOL) Starter

Stator Resistance Starter: To apply reduced voltage to the stator, resistances are added in series to the three phases of the Stator using Rheostats as shown in the figure below. Initially maximum resistance is included in the stator circuit indicated in the figure as 'START' position. In this position of the Rheostat reduced voltage gets applied to the stator resulting in a less starting current. Once the motor starts picking up speed, the resistance is gradually removed from the circuit and brought to the 'RUN 'Position as shown in the figure. The motor runs at the rated speed.

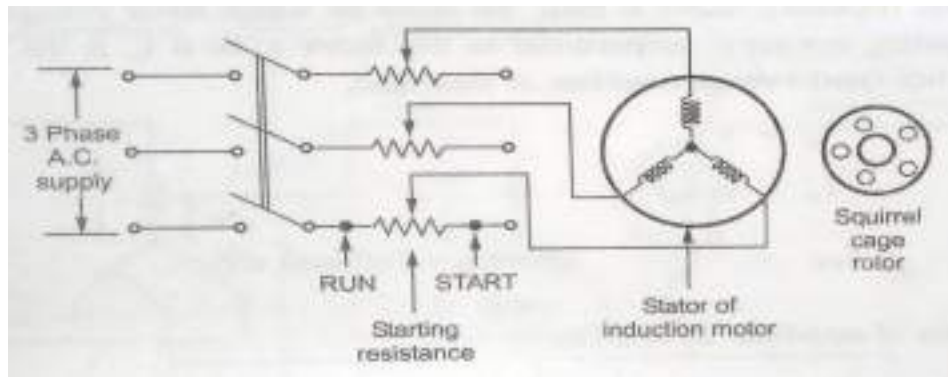

Figure: Stator resistance starter

The *advantage* of this type of starter is, it is economical, simple and can be used with both Star and Delta winding motors.

The *disadvantage* is large power losses due to large resistances in the stator circuit at the time of start and lesser Starting Torques due to reduced applied voltages ($T = k [s E_2^2 R_2 / R_2^2 + (sX_2)^2]$)

Relation between T_{ST} and T_{FL} :

We know that $P_{AG} = T_{IND} \cdot \omega_s$ which means that $T_{IND} = P_{AG} / \omega_s$ or $T_{IND} \propto P_{AG}$ since ω_s , the synchronous speed is constant.

We also know that $P_{AG} = P_{cl}/s$ (where P_{cl} Total copper loss) = $3I_2^2 R_2/s$ which means that $T_{IND} \propto I_2^2/R_2$.

But we know that rotor current I_2 and stator current I_1 are also related by their turns ratio and so we can say that

$T_{IND} \propto I_1^2/s$ where I_1 is the stator current.

At start, $s=1$, $T_{IND} = T_{ST}$ and $I_1 = I_{ST}$

Therefore $T_{ST} \propto I_{ST}^2$

When stator resistance starter is used, let 'x' be the factor by which the stator voltage is reduced (where $x < 1$). Then the starting current I_{ST} gets multiplied by this 'x'. So if I_{SC} is the normal short circuit current drawn by the motor at start under full rated voltage condition then:

$$I_{ST} = xI_{SC} \text{ and } T_{ST} \propto (xI_{SC})^2 \text{ ----- (1)}$$

$$\text{But } T_{FL} \propto I_{FL}^2 / s_f \text{ where } s_f = \text{slip at full load ----- (2)}$$

$$\text{Dividing (1) by (2) we have : } T_{ST}/T_{FL} = x^2 [I_{SC}/I_{FL}]^2 s_f$$

So we can see that as $x < 1$, the starting torque reduces by x^2 times with stator resistance starter.

Auto Transformer Starter:

Connection of a Three Phase Auto Transformer Starter to reduce the applied voltage using a '**Six Pole Double Throw switch**' is shown in the figure (a) below. When the switch is in the '**START**' Position reduced voltage is applied to the Stator. The reduction in applied voltage is by a factor 'x' as shown in the figure (b) below. When the Motor speed approaches the Normal speed, the switch is brought to the '**RUN**' Position, thus applying full rated voltage to the Motor. Changing of switch position can be done automatically using Contactors and Relays.

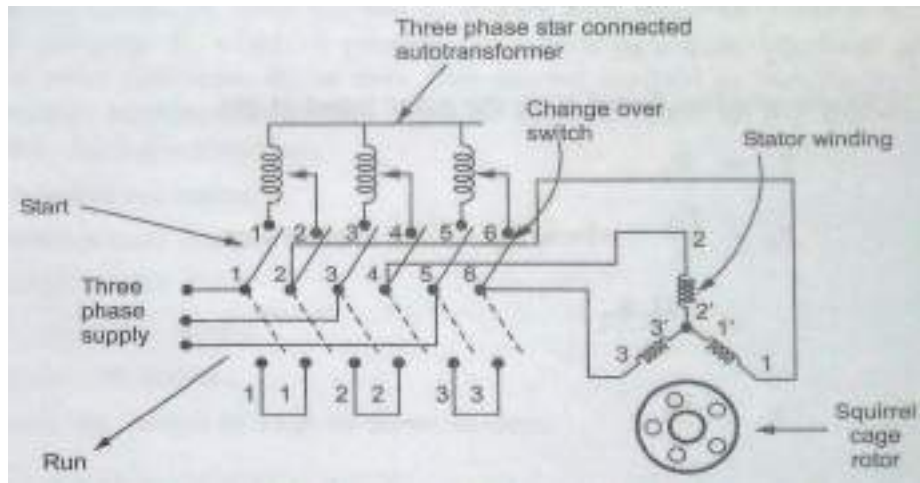
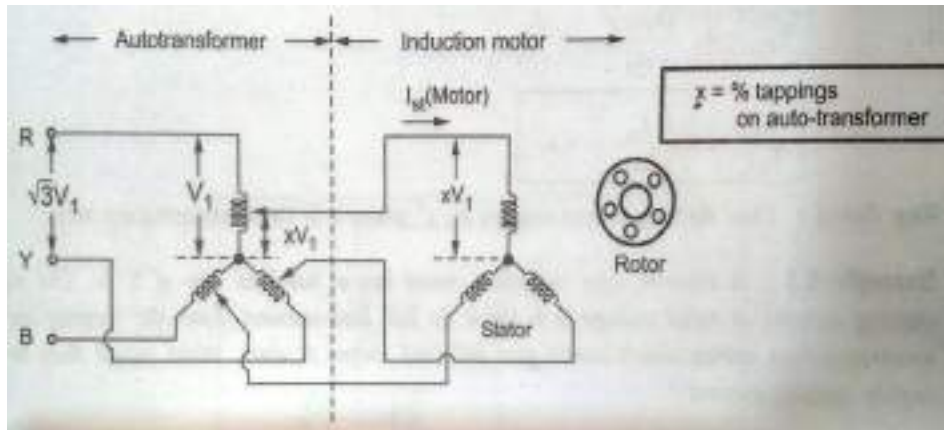

Figure (a): Auto Transformer starter



Figure(b): Use of Auto Transformer starter to reduce voltage at 'start'

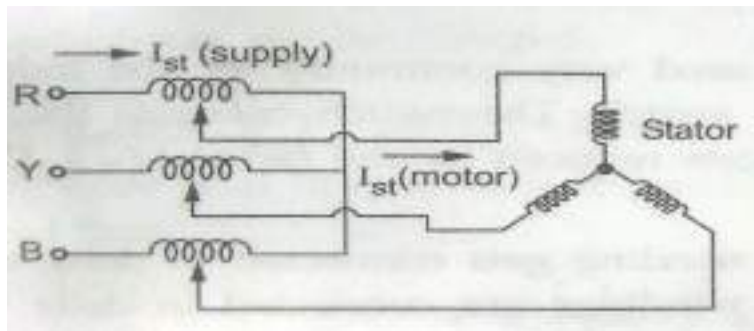

Figure : Showing the difference between $I_{ST}(\text{Motor})$ and $I_{ST}(\text{Supply})$

Relation between T_{ST} and T_{FL} :

In this case also the applied voltage to the motor gets reduced by the same fraction ' x ' ($x < 1$) but by auto transformer action instead of by the introduction of resistance. So here also the relation between T_{ST} and T_{FL} is same as what we got for Resistance introduction method. i.e.

$$T_{ST}/T_{FL} = x^2 [I_{SC}/I_{FL}]^2 s_f$$

Star Delta Starter:

This is the most commonly used starter for induction motors. It uses **TPDT (Triple pole double throw switch)** in conjunction with a **TPST** switch to feed input power as shown in the figure below. Initially the **TPDT** switch connects the three windings of the Induction motor in star configuration and then when the motor picks up speed its position is changed so that the motor windings get connected in delta configuration. So initially $1/\sqrt{3}$ times the line voltage gets applied to each phase of the motor and after changing the **TPDT** switch to the other position full line voltage gets applied to the motor.

The operation of the bulky switch can be avoided by using contactors /relays along with push button switches and operation can be made automatic such that the motor will never start in **RUN (Delta)** position but will always start in **START position (Star)** only.

The advantage of this starter is it is economical and requires very little maintenance. But the disadvantage is, it can be used for motors that operate in Delta in running condition only and reduction factor of $1/\sqrt{3}$ is fixed and cannot be changed.

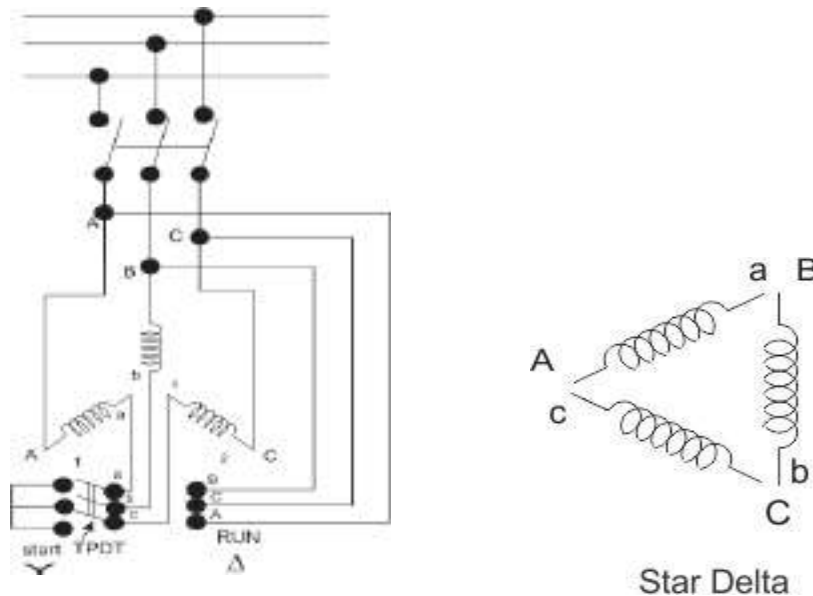

Figure : Star Delta Starter

Relation between T_{ST} and T_{FL} :

Here also the relation is same as what we obtained in the earlier methods of Resistance Introduction and Autotransformer except that the multiplying factor 'x' is of fixed value $1/\sqrt{3}$. Hence

$$T_{ST}/T_{FL} = x^2 [I_{SC}/I_{FL}]^2 s_f = (1/\sqrt{3})^2 [I_{SC}/I_{FL}]^2 s_f = (1/3) [I_{SC}/I_{FL}]^2 s_f$$

Where I_{SC} = Starting phase current at rated voltage with motor in Delta

Where I_{FL} = Fullloadphase current at rated voltage with motor in Delta

Comparison of current drawn from the lines when windings are Star Connected and Delta connected:

In a Star - Delta Starter the current drawn by the motor from the lines is reduced to 1/3 as compared to the current it would have drawn if connected in delta. This is shown with the help of the figure below.

It is seen that for star-connection of windings, phase current is equal to line current, i.e.,

$$I_p = I_{LY} = \frac{V_p}{Z_p} = \frac{V}{\sqrt{3}Z_p}$$

where I_p is the phase current, I_{LY} is the line current when windings are star-connected and Z_p is the winding impedance per phase, V_p is the phase voltage and V is the line voltage (and $V_p = V/\sqrt{3}$)

For delta-connection of windings, $V_p = V$. And So,

$$I_p = \frac{V}{Z_p} \text{ and } I_{L\Delta} = \sqrt{3} I_p = \sqrt{3} \frac{V}{Z_p}$$

The ratio of line currents drawn in star and delta-connection is therefore,

$$\frac{I_{LY}}{I_{L\Delta}} = \frac{V}{\sqrt{3}Z_p} \frac{Z_p}{\sqrt{3}V} = \frac{1}{3} \quad \text{Or} \quad I_{LY} = \frac{1}{3} I_{L\Delta}$$

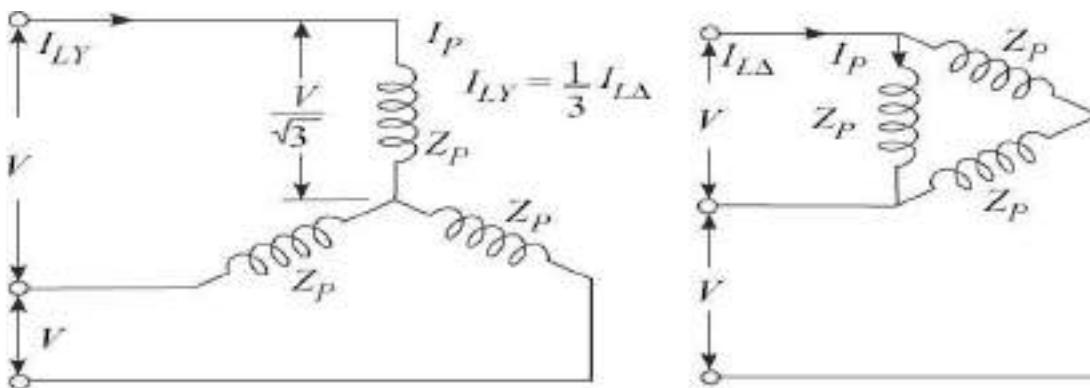

Figure: Comparison of current drawn from the lines when windings are star Connected and Delta connected

Thus by connecting the motor windings, first in Star and then in Delta, the line current drawn by the motor at starting is reduced to one-third as compared to starting with the windings delta connected.

From expression for the torque developed in an Induction motor it is known that torque developed by an induction motor is proportional to the square of the applied voltage. In star connection of windings, the phase voltage is $1/\sqrt{3}$ times the line voltage. So, the starting torque will be reduced to one-third.

Rotor Resistance Starter:

To limit the supply current, Rotor current can also be limited since this in turn limits the supply current. To limit the Rotor current, three phase star connected Resistances (Rheostats) are used as shown in the figure below. The additional Resistances are added in the Rotor circuit through Slip Rings and Brushes. Initially maximum resistance is included in the circuit and then once the Motor approaches the normal speed, the resistances are cutout gradually. Since the Torque is proportional to Rotor resistance this method increases the starting Torque also in addition to limiting the input supply current.

The limitation of this method is that it can be used only with Slip Ring Induction Motors and not with Squirrel Cage Induction Motors since the Rotor conductors in them are permanently short circuited.

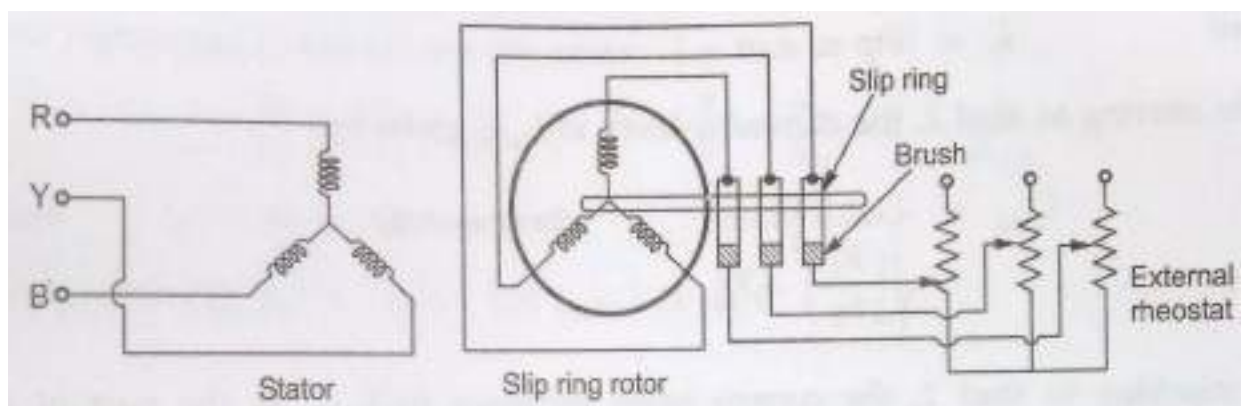

Figure: Rotor Resistance Starter

Direct On Line (DOL) Starter:

In case of small motors with rating less than 5 H.P , the starting currents are not that high to damage the winding and so Starter is not required to reduce the voltage at the time of starting. But for such small motors also certain protection features against over current, under voltage and single phasing are required and they are provided by a starter known as Direct On Line (DOL) starter. This type of starter does not reduce the applied voltage at the time of starting and applies the line voltage directly on to the stator but has the protection features mentioned above.

The connection diagram of DOL starter is shown in the figure below. The NO (Normally Open) contact and the NC (Normally Closed) contact are the contacts provided by two separate Push Button switches ON and OFF respectively which will give the change over only until the push button is kept pressed. i.e. they are not latching type of switches we notice in our homes. The contact comes back to the original condition once the push button is released. But they are used along with a coil (Known as latching coil) to keep the contact in the changed condition until the other switch is operated. This operation is as follows.

When the ON switch is closed, the coil gets energized and activates the CONTACTOR which extends the Input supply power to the motor. In addition to the three main contacts, an auxiliary contact also gets operated which keeps the contactor in ON condition as long as supply is ON. When the OFF switch is pressed the NC contact breaks the two phase supply to the contactor coil and thus the coil gets deenergized. Then the main contactor contacts open up thus disconnecting the Motor from the incoming supply.

Under over load condition current drawn by the motor increases due to which the thermal over load relay contacts get excessively heated up and open up the line (Bimetallic effect) thus disconnecting the motor from the input supply. Similarly under low voltage conditions the coil does not get adequate supply and it gets

deactivated thus again disconnecting the motor from the input supply and protecting it against abnormal conditions.

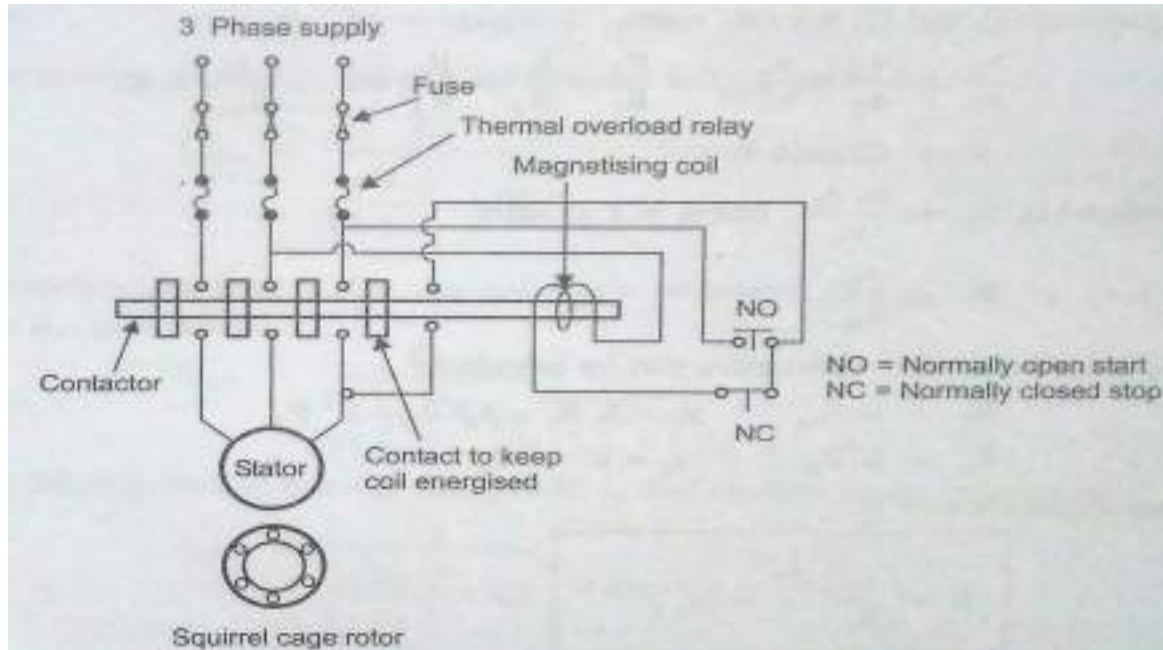

Figure: Direct On Line Starter

Speed control:

Introduction:

For an Induction Motor we know that : $N_m = N_s(1-s)$

From this expression it can be seen that the speed of the Induction Motor changed either by changing the synchronous speed N_s (Since $N_s = 120f/P$) or the slip 's'.

Similarly the Torque produced in a Three Phase Induction motor is given by:

$$T \propto \frac{sE_2^2 R_2}{[R_2 + (sX_2)^2]}$$

So when the parameters like R_2 and E_2 are changed, then to keep the Torque constant corresponding to the constant load condition, the motor reacts by change in slip and effectively the speed changes. So, the speed of the Induction Motor can be controlled in two ways.

From stator side:

1. Supply frequency control to change N_s (Since $N_s = 120f/P$)
2. Supply voltage control (which in turn changes E_2)
3. Controlling the number of poles P which in turn changes N_s (Since $N_s = 120f/P$)

From Rotor side :

1. Adding external resistance in the Rotor side (Change in R_2)
2. Cascade control
3. Injecting slip frequency voltage into the Rotor circuit

Let us study these methods one by one.

Speed Control by Changing the Line Frequency:

If the electrical frequency applied to the stator of an induction motor is changed, the rate of rotation of its magnetic fields N_s will change in direct proportion to the change in electrical frequency, (given by $N_s = 120 f / P$) and the no- load point on the torque-speed Characteristic curve will change with it (see Figure “a” below). The synchronous speed of the motor at rated conditions is known as the **base speed**. By using variable frequency control, it is possible to adjust the speed of the motor either above or below the base speed. A properly designed variable-frequency induction motor drive can be *very* flexible. It can control the speed of an induction motor over a range from as little as 5 percent of base speed up to about twice base speed. However, it is important to maintain certain voltage and torque limits on the motor as the frequency is varied, to ensure safe and efficient operation.

When running at speeds below the base speed of the motor, it is necessary to reduce the terminal voltage applied to the stator for proper operation. The terminal voltage applied to the stator should be decreased linearly with decreasing stator frequency. This process is called *derating*. If it is not done, the steel in the core of the induction motor will saturate and excessive magnetization currents will flow in the machine.

From the basic transformer voltage equation we have the expression for the air gap flux:

$$\Phi = \frac{1}{4.44 K_1 T_{ph1}} \left(\frac{V}{f} \right) \dots \dots \dots (1)$$

Where K_1 = Stator winding constant, T_{ph1} = Stator turns /phase, V = Supply voltage and f = Supply frequency

From the above expression it can be seen that if the frequency is reduced the flux will increase which results in saturation of the stator and rotor magnetic cores. This saturation in turn results in increase in magnetization current (no load current) which is undesirable. Hence it is required to maintain the air gap flux constant when supply frequency is changed. From the above expression for flux Φ we can see that this can be achieved by changing the Voltage also correspondingly so as to maintain a constant V/f ratio. Hence with V/f control method which ensures constant flux Φ , we can get smooth speed control.

Such a constant V/f with both variable voltage and frequency can be obtained using a electronic converter and an inverter as shown in the figure below.

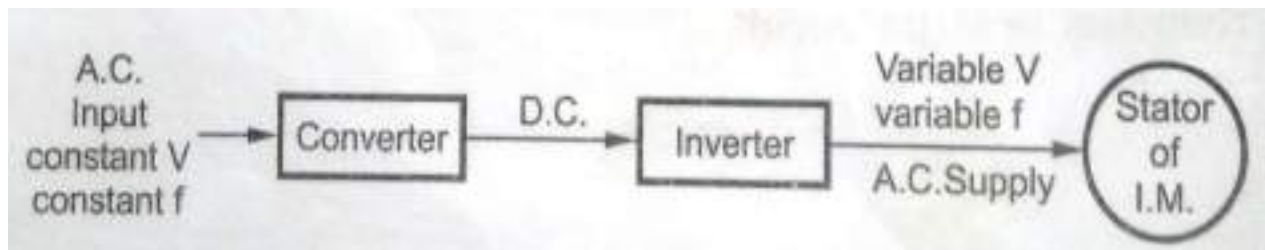

Figure: Electronic V/f control scheme

The converter converts the normal input power supply into DC. The inverter then converts the DC supply into a variable frequency supply as per the speed required and maintaining a constant V/f .

Figure (a) below shows a family of induction motor torque-speed characteristic curves for speeds below base speed, assuming that the magnitude of the stator voltage varies linearly with frequency.

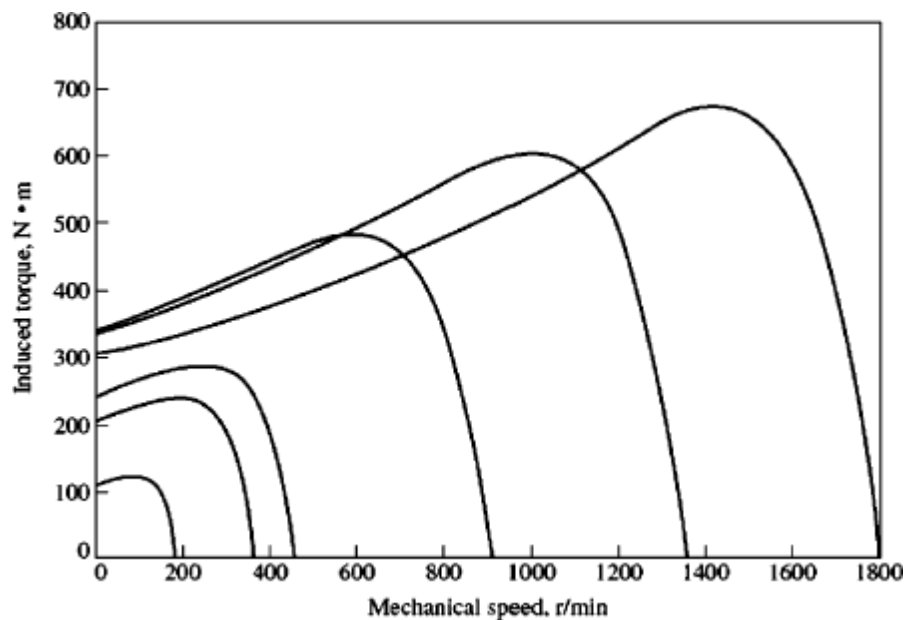

Figure (a): Variable-frequency speed control in an induction motor: (a) The family of torque-speed characteristic curves for speeds below base speed. Assuming that the line voltage is derated linearly with frequency.

When the electrical frequency applied to the motor exceeds the rated frequency of the motor, the stator voltage is held constant at the rated value. Although saturation considerations would permit the voltage to be raised above the rated value under these circumstances, it is limited to the rated voltage to protect the winding insulation of the motor. The higher the electrical frequency above base speed, the larger the denominator of Equation (1) becomes. Since the numerator

term is held constant above rated frequency, the resulting flux in the machine decreases and the maximum torque decreases with it. Figure (b) below shows a family of induction motor torque- speed characteristic curves for speeds above base speed, assuming that the stator voltage is held constant.

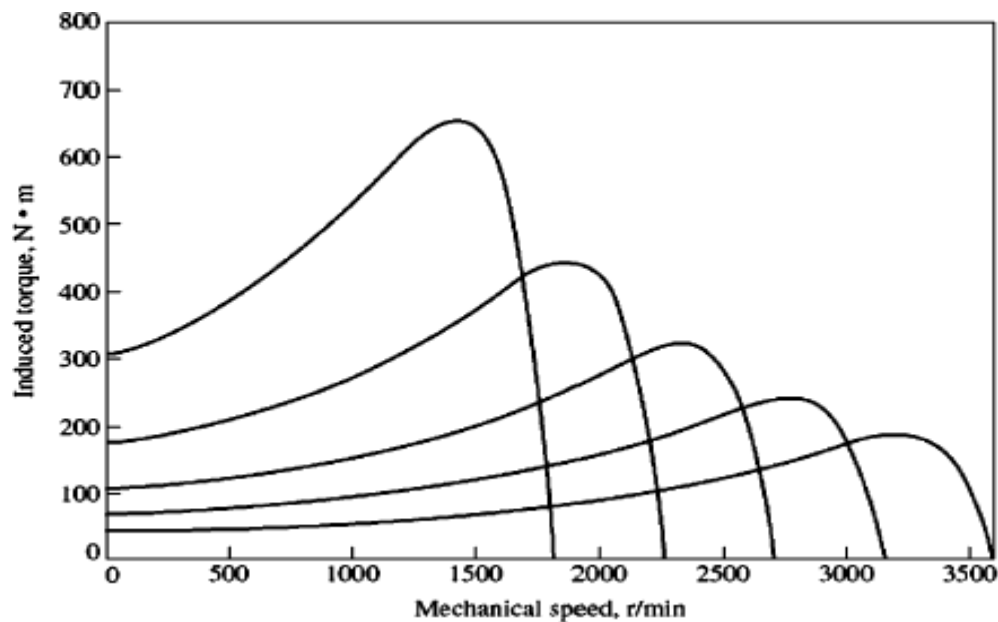
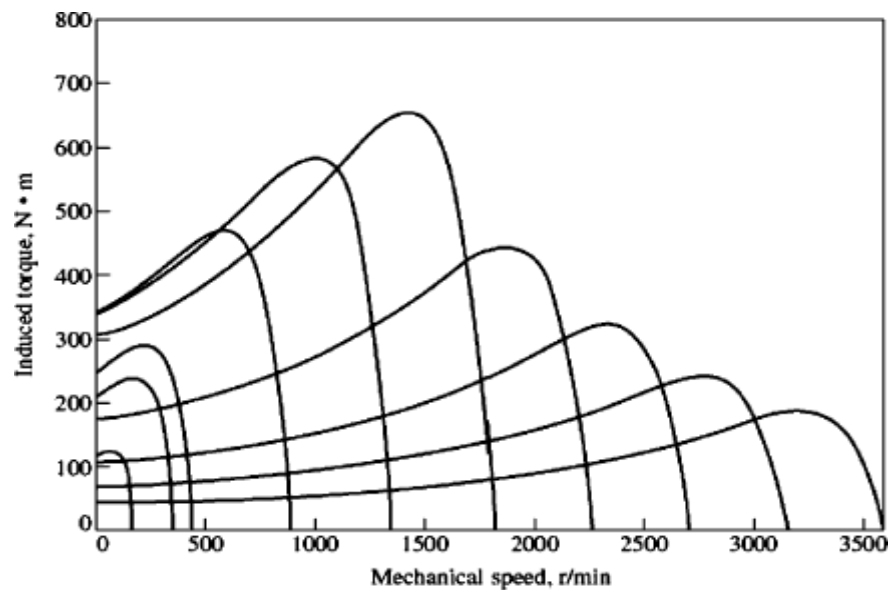

Figure (b) : Variable-frequency speed control in an induction motor: The family of torque speed characteristic curves for speeds above base speed assuming that the line voltage is held constant.

If the stator voltage is varied linearly with frequency below base speed and is held constant at rated value above base speed, then the resulting family of torque-speed characteristics are as shown in the figure (c) below.



(C) Variable-frequency speed control in an induction motor .The torque-speed characteristic curves for all frequencies.

In the past, the principal disadvantage of electrical frequency control as a method of speed changing was that a dedicated generator or mechanical frequency changer was required to make it operate. This problem has disappeared with the development of modern solid-state variable- frequency motor drives. In fact, changing the line frequency with solid-state motor drives has now become the method of choice for induction motor speed control. Note that this method can be used with *any* induction motor, unlike the pole-changing technique, which requires a motor with special stator windings.

Speed Control by Changing the Line Voltage:

If a load has a torque-speed characteristic such as the one shown in figure below, then the speed of the motor may be controlled over a limited range by varying the line voltage. This method of speed control is sometimes used on small motors driving fans.

We know that the torque developed by an induction motor is proportional to the square of the applied voltage. Hence speed of an induction motor can also be varied by changing the applied stator voltage. If the voltage is reduced, torque is

reduced as the square of the voltage. For example, if the applied voltage is reduced from V to $0.9 V$, the torque will be reduced from T to $0.81 T$. The torque-speed characteristic at reduced stator voltage say $0.9 V$ is shown in the figure below for Load with constant Torque over the given speed range. Since the torque is reduced to 81 per cent, the rotor cannot continue to rotate at speed N_1 , and its speed will be reduced, i.e., its slip will increase until the increased rotor current (and Increased Torque will make up for the reduced stator voltage and produce the required load torque at a lower speed N_2 . This method of speed control is rarely used for industrial three-phase motors because of the requirement of additional costly voltage changing auxiliary equipment. It is used for small induction motors used in home appliances.

The Torque Speed Characteristics of Induction motors with stator voltage control with a load torque increasing with speed along with the range of speed control is also shown in the figure below.

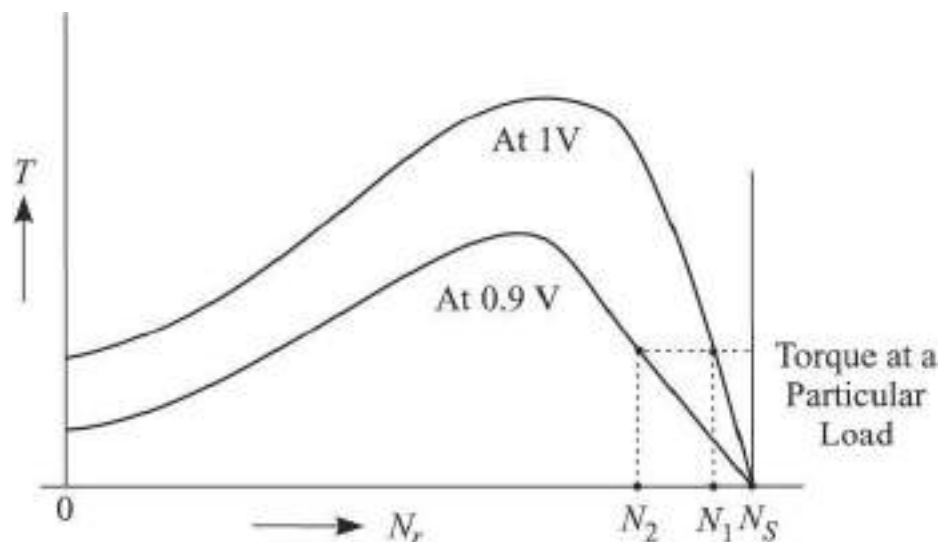

Figure: Variation of motor speed due to variation of stator applied voltage (with Constant Load Torque over the complete speed range)

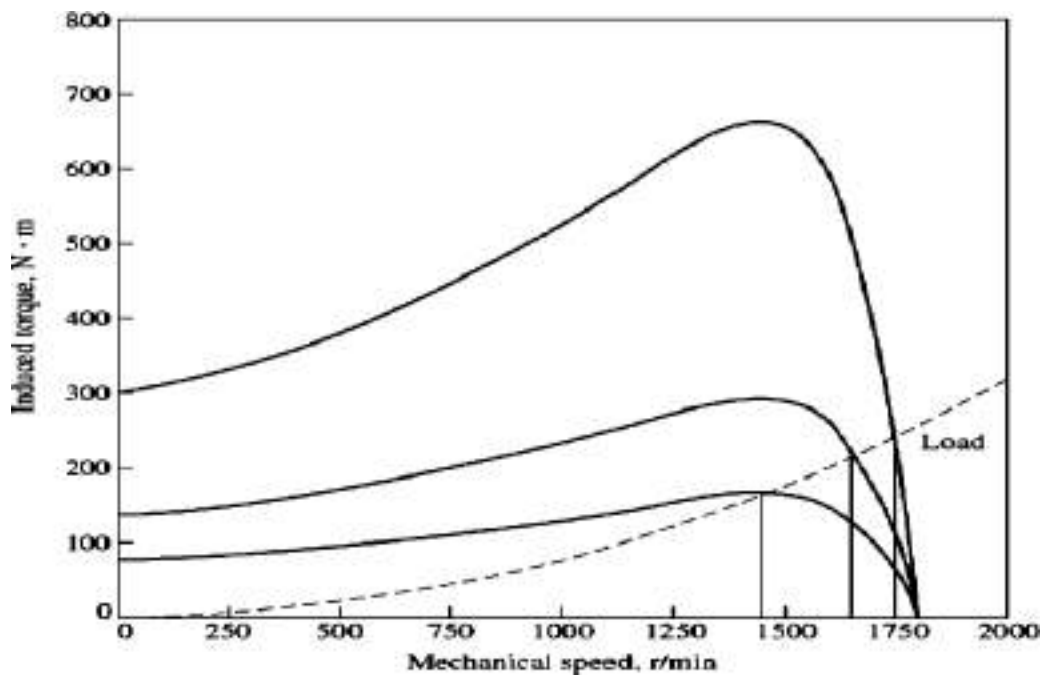

Figure: Variable-line-voltage speed control in an induction motor (with a load with increasing Load Torque as speed increases)

Speed control of Slip ring Induction Motors by changing Rotor resistance:

In slip-ring type motors, slip at a particular load can be changed by changing the rotor circuit resistance. In squirrel-cage motors, rotor circuit resistance cannot be varied. Therefore, speed of squirrel-cage type motors cannot be varied by changing of slip. The effect of change of rotor circuit resistance on slip when the motor is connected to a mechanical load is shown in Fig. below . Torque-slip characteristics corresponding to rotor resistances R_1 and R_2 are shown respectively by the curves A and B. Curve L shows the load characteristic. The motor runs at a slip, S_1 with R_1 as its rotor circuit resistance.

Figure below Shows the change of rotor slip with change of rotor circuit resistance when the motor is running with a particular load with rotor circuit resistance R_2 which is greater than R_1 , the rotor slip increases from S_1 to S_2 . Thus

the speed of the rotor decreases. If we further change the rotor circuit resistance, the speed of the motor will change to a new value as indicated by slip S_3 .

Thus, the speed of the motor can be varied by changing the rotor circuit resistance.

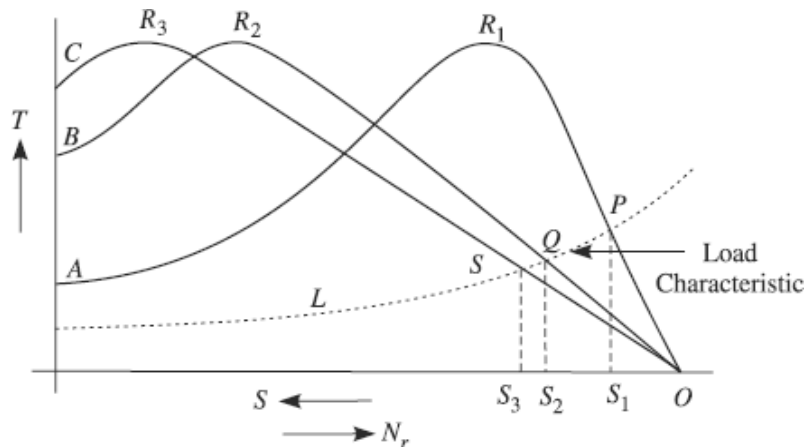

Figure: Speed control of Slip ring Induction Motors by changing Rotor resistance (Shown with load torque increasing with speed)

Disadvantages:

Decreased Efficiency Due to Power Lost in the External Rotor Circuit Resistance:

At higher values of slip, the rotor current and hence rotor I^2R loss are increased considerably. This can be better understood by referring back to expression,

$$\text{Rotor } I^2R\text{-loss} = \text{Slip} \times \text{Rotor input}$$

If slip is increased, rotor I^2R -losses increase. At 50 per cent slip, for example, half of the rotor input will be wasted as rotor I^2R -loss.

Poor Speed Regulation when the Motor is working with Higher Rotor Circuit Resistance:

Figure below shows the torque-speed characteristics of an induction motor for two values of rotor-circuit resistance R_1 and R_2 . Speed regulation is expressed as the variation of speed as the load on the motor varies. From the figure below it can be seen that for change of load from half-load to full-load, the variation

of motor speed is from N_1 to N_2 with R_1 as the rotor-circuit resistance. The variation of speed is N_3 to N_4 for R_2 as the rotor-circuit resistance which is much higher in this case as compared to the variation with R_1 as rotor-circuit resistance, i.e.

$$(N_3 - N_4) > (N_1 - N_2).$$

Although by changing the rotor-circuit resistance from R_1 to R_2 at a particular load, say at half-load, the speed can be changed from N_1 to N_3 but the speed regulation, i.e., the variation of speed with variation of load becomes higher with higher rotor circuit resistance.

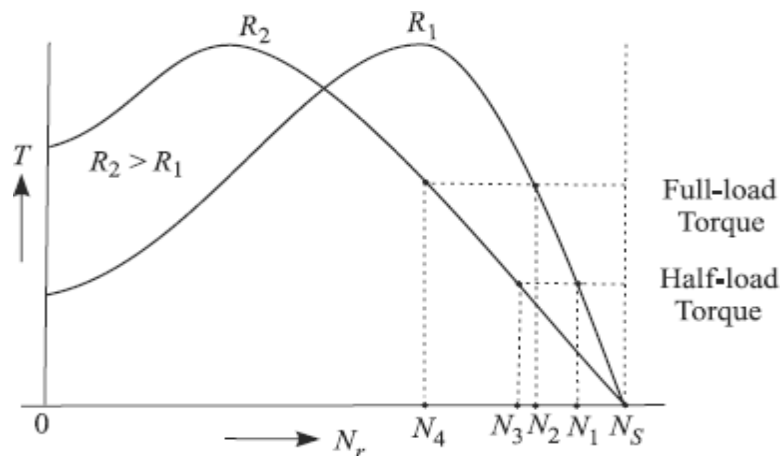

Figure: Speed regulation with different values of rotor circuit resistance

Change of poles and method of consequent poles:

From the basic expression for synchronous speed $N_s = 120 f / P$ we can see that the speed can be changed by changing the number of stator poles. With this method we can get discrete speeds in steps of 1, 2, 4 etc. but we cannot get a smooth continuous speed control. Stator poles can be controlled by any of the following two methods.

- (1) Two Separate Windings on the Stator
- (2) Consequent poles method

Two Separate Windings on the Stator:

An induction motor stator is wound for a definite number of poles. The speed of an induction motor depends upon the number of poles for which the stator is wound. If instead of one stator winding, two independent windings, for different number of poles say for four poles and for eight poles are made on the stator, two definite rotor speeds can be obtained. The two windings are to be insulated from one another. When any of the windings is used, the other winding should be kept open circuited by the switch or at least left in star-connection. In the rotor, poles are formed in accordance with the number of poles in the stator circuit. The limitation of this method is that, only two definite speeds can be obtained. Smooth control of speed over a wide range is not possible.

Speed Control Using Consequent-pole Technique:

An alternative method is to use only one winding wound for a particular number of poles, but the end connections of the coils with the supply is changed such that different number of poles are formed. This is explained in a simplified manner in the figure below. Only one stator phase winding of a balanced three-phase, squirrel-cage motor is shown for ease of understanding. In figure (a), a simplified 2-pole stator winding is shown where the supply is given to a parallel combination of coils **11'** and **22'**. In figure (b) the coils **11'** and **22'** are shown to be connected in series thus resulting in set of 4 poles.

With the combination of having two separate windings on the stator and by series / parallel connections of the coils across the supply, four distinct speeds of the rotor also can be obtained.

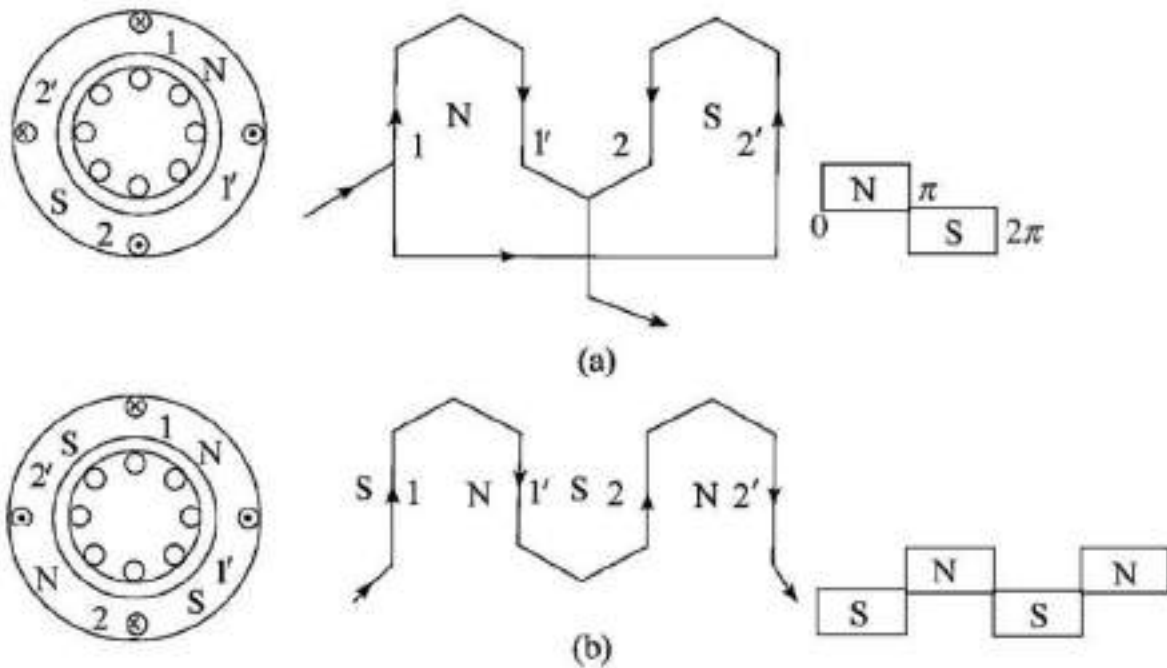

Figure: Pole changing method of speed control (a) Parallel connection of coils (b) Series connection of coils

Cascade connection:

This method is also called *tandem* operation of Induction Motors. In this method two Induction Motors are mounted on the same shaft. One, a slip ring motor called the Main Motor and the second one called an auxiliary motor which can be a slip ring or a squirrel cage motor. The arrangement is shown in the figure below.

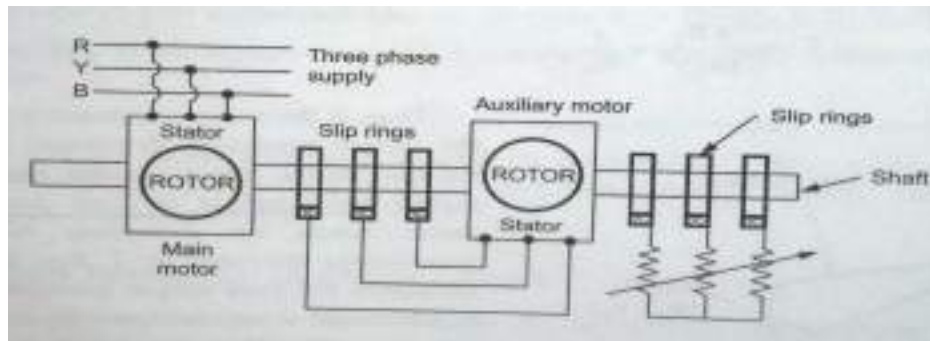

Figure: Cascade control of two Induction Motors

The main motor is connected to the three phase supply. The supply for the auxiliary motor is derived at slip frequency from the slip rings of the main motor. Thus the slip power of first (main) motor is utilized by the second motor whose mechanical output is utilized by the main motor since both are connected on the same shaft. This is called cascading of the motors. If the torques produced by the two motors act in the same direction Cascading is '**cumulative**' and if they act in opposite direction cascading is '**differential**'.

Derivation of the possible speeds:

Let P_A = Number of poles in Main Motor

Let P_B = Number of poles in Auxiliary Motor and

f = Supply frequency

Then, $N_{SA} = 120 f / P_A$

Let N = Speed of the set which is same for both the motors as they are mounted on the same shaft.

$s_A = (N_{SA} - N) / N_{SA}$ (Slip of motor A)

f_A = Frequency of Rotor Induced e.m.f. in motor A. Then $f_A = s_A f$

The supply to motor **B** is at a frequency f_A . i.e. $f_B = f_A$

Hence, $N_{SB} = 120 f_B / P_B = 120 f_A / P_B = 120_{SA} f / P_B = 120 (N_{SA} - N) f / P_B \cdot N_{SA}$

Now on No load, the speed of the Rotor **B** i.e. N is almost equal to its synchronous speed N_{SB} i.e. $N_{SB} = N$

$$N = 120 [(N_{SA} - N) / N_{SA}] \cdot (f / P_B) = 120 (f / P_B) [1 - (N / N_{SA})]$$

$$= 120 (f / P_B) [1 - N / (120 f / P_A)]$$

$$N = 120 (f / P_B) [1 - (N P_A / 120 f)]$$

Therefore: $N [1 + (P_A / P_B)] = 120 (f / P_B)$ and finally

$$N = 120 (f / P_A + P_B)$$

Thus the speed N of the set is decided by the total number of poles equal to $(P_A + P_B)$. This is possible in *cumulatively compounded motors*.

By interchanging any two terminals of Motor **B**, the reversal of direction of rotating magnetic field **B** is achieved and then the set runs as a differentially cascaded set. In such a case the effective number of Poles would be $(P_A - P_B)$.

Thus we get four different speeds.

1. Synchronous speed of **A** independently with motor **B** disconnected.

$$N_{SA} = 120 f / P_A$$

2. Synchronous speed of **B** independently with motor **A** disconnected and Motor **B** alone directly connected to the supply: $N_{SB} = 120 f / P_B$

3. Running the two motors A and B cumulatively:

$$N_{SABC} = 120 f / (P_A + P_B)$$

4. Running the two motors A and B differentially:

$$N_{SABD} = 120 f / (P_A - P_B)$$

Disadvantages:

- Requires two motors and hence expensive.
- Smooth speed control is not possible. Only four discrete speeds are possible.
- Set *cannot* be operated if $P_A = P_B$
- Operation is complex and starting torque may not be adequate.

Injection of an e.m.f into rotor circuit (qualitative treatment only):

In this method a voltage is injected into the Rotor circuit. The frequency of Rotor circuit is at slip frequency and hence the voltage to be injected must also be at a slip frequency.

The injected voltage may oppose or assist the Rotor induced voltage. If it is in phase opposition, effective Rotor resistance increases. If it is in phase the Rotor Resistance decreases. Thus by controlling the magnitude of the injected e.m.f., Rotor resistance and thus effectively Motor speed can be controlled.

Practically two methods are available which use this principle. These methods are:

1. Kramer system
2. Scherbius system

These two are basically methods of slip power recovery by cascading connections and are effectively equivalent to Speed control by external e.m.f. injection into the rotor circuit.

Kramer System:

The Kramer system is applicable for only sub synchronous speed operation. Figure below shows a conventional Kramer system. The system consists of a 3 phase rotary converter and a DC motor. The slip power is converted into dc power by a rotary converter and fed to the armature of the DC motor. The slip ring induction

motor is coupled to the shaft of the dc motor. The slip rings are connected to a '**rotary converter**' which basically converts the 3 phase ac input at slip frequency to DC. The dc output of rotary converter is used to drive a dc motor. The rotary converter and dc motor are excited from the dc bus bars or from an exciter. The speed of slip ring induction motor is adjusted by adjusting the speed of dc motor with the help of a field regulator. This system is also called the electromechanical cascade, because the slip frequency power is returned as mechanical power to the slip ring induction motor shaft by the DC motor.

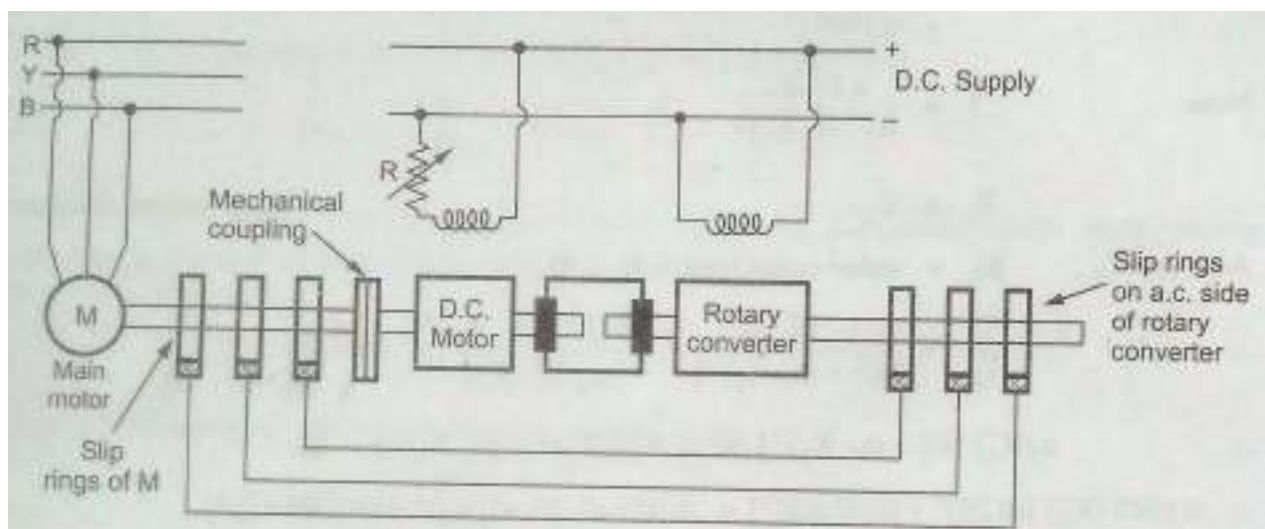

Figure: Conventional Kramer System

If the mechanical losses in cascade system are neglected the shaft power output P_m of the SRIM motor is given by :

$$P_m = (1-s) P_{in}$$

Where P_{in} = input power to the stator and 's' is the slip. The slip power $P_s = sP_{in}$ is added to P_m by converting it first to DC by Rotary converter and then to mechanical power by the DC motor. This mechanical power is fed to the slip ring induction motor shaft. This method is used for large motors of the order of 4000KW or above.

Advantages:

1. The main advantage of this method is that any speed, within the working range can be obtained.
2. If the rotary converter is over excited, it will take a leading current which compensates for the lagging current drawn by SRIM and hence improves the power factor of the system

The Scherbius system:

This is similar to Kramer system but the only difference is that in the Kramer system the return power is mechanical and in the Scherbius system the return power is electrical. Conventional Scherbius Drive is shown in the figure below.

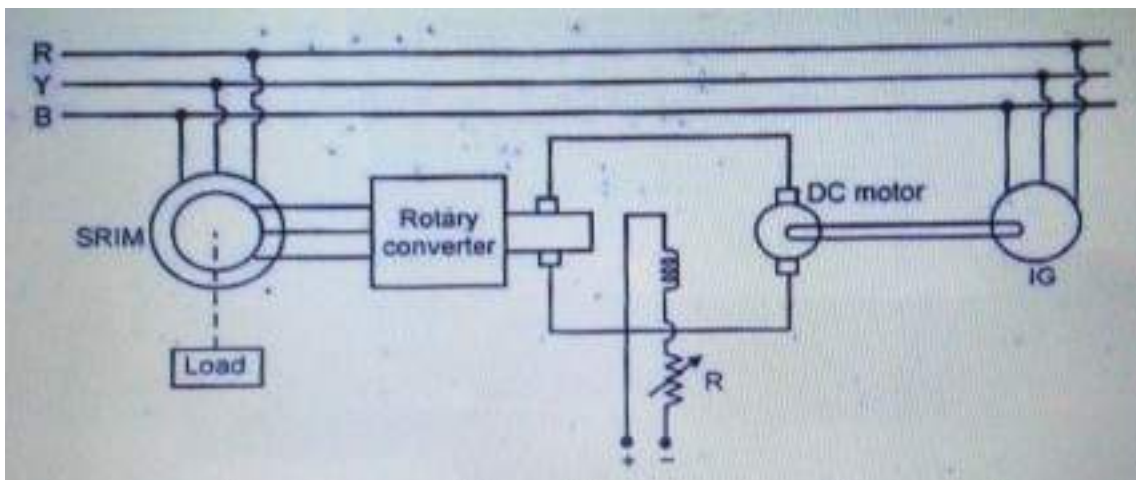

Figure: Scherbius System

Here the rotary converter converts slip power into DC power and the DC power is fed to a DC motor. The DC motor is coupled to an Induction Generator. The induction generator converts the mechanical power into electrical power and returns it to the supply line. The SRIM speed can be controlled by varying the field regulator of the dc motor.

Induction generator principle of operation:

If the rotor is made to rotate at a speed more than the synchronous speed, the slip becomes negative. A rotor current is generated in the opposite direction, due to the rotor conductors cutting stator magnetic field in the other direction. This generated rotor current produces a rotating magnetic field in the rotor which will now push (forces in opposite way) the stator field. (When the machine was working at lesser than the synchronous speed, the rotor magnetic field was trying to follow the stator magnetic field) This causes a stator voltage which pushes current flowing out of the stator winding against the applied voltage. Thus, the machine now works as an induction generator (asynchronous generator).

This basic concept of an Induction machine working as a motor (with a positive slip) and as a generator (with negative slip) is illustrated in the following Torque slip characteristics.

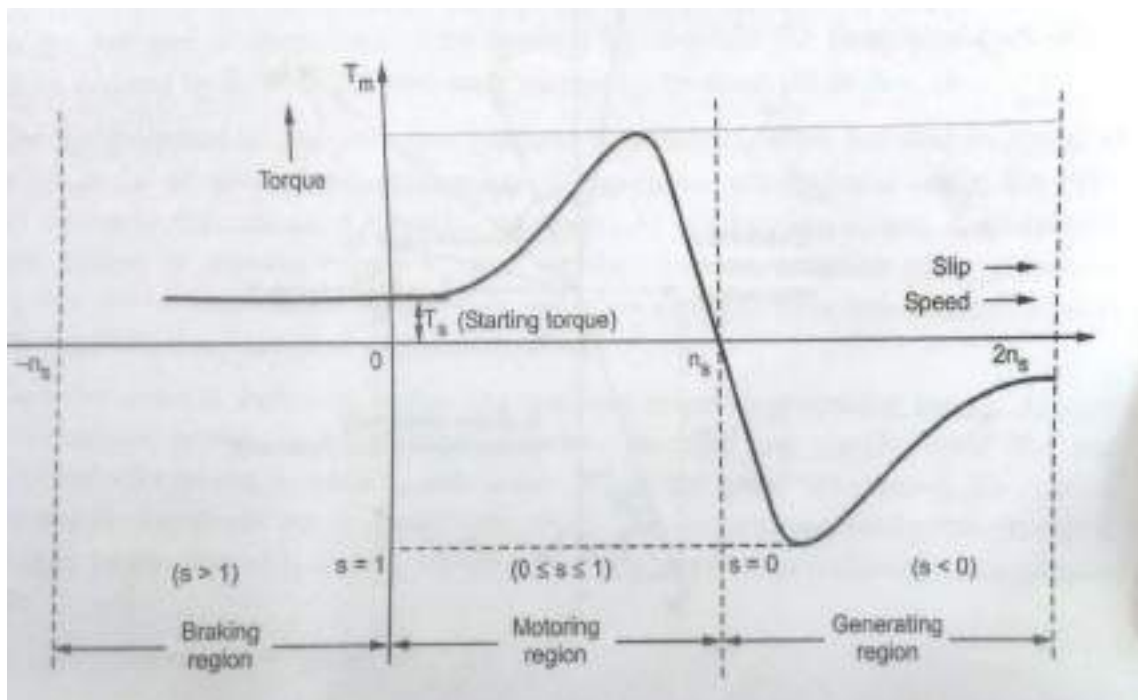

Torque Slip Characteristics of an Induction Machine

Grid connected Induction Generator:

Induction generator is not a self-excited machine. Reactive power is needed for producing rotating magnetic field. Therefore, when running as a generator, the machine takes reactive power from the AC power grid and supplies active power back into the grid. The active power supplied back into the line is proportional to the slip above the synchronous speed. The basic connection diagram of a Grid connected Induction motor is shown in the figure below.

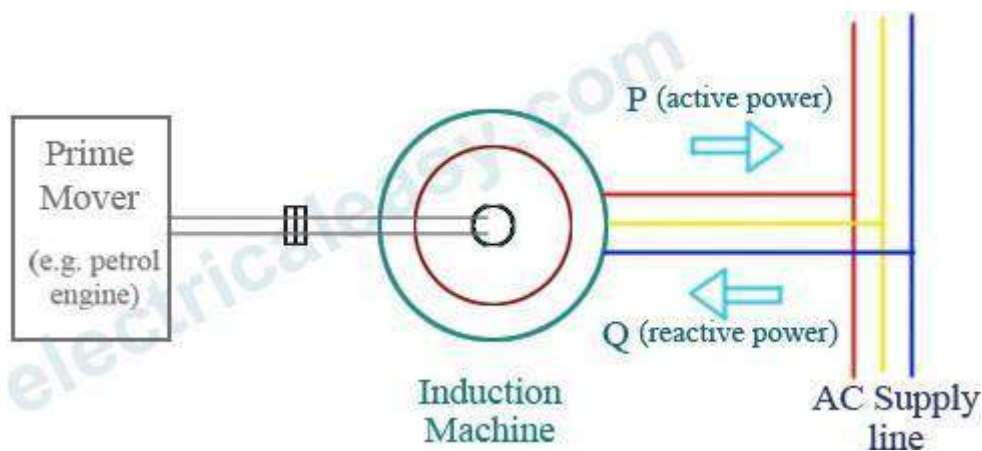

Figure: Grid connected Induction Generator

Self-Excited Induction Generator:

It is clear that, an induction machine needs reactive power for excitation, regardless of whether it is operating as a generator or a motor. When an induction generator is connected to a grid, it takes reactive power from the grid. But if we want to use an induction generator to supply a load without using an external source (e.g. grid) a capacitor bank must be connected across the stator terminals to supply reactive power to the machine as well as to the load as shown in the figure below. When the rotor is rotated at an enough speed, a small voltage is generated across the stator terminals due to residual magnetism. Due to this

small generated voltage, capacitor current is produced which provides further reactive power for magnetization.

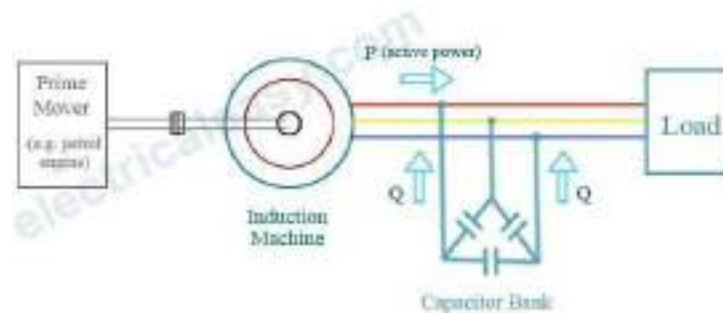

Figure: Stand alone Induction Generator

Applications: Induction generators produce useful power even at varying rotor speeds. Hence they are suitable for wind turbines.

Advantages: Induction or asynchronous generators are more rugged and require no commutator and brush arrangement (as needed in case of synchronous generators.)

One of the major disadvantages of induction generators is that they take quite a large amount of reactive power from the Grid .

Illustrative Problems:

Example 1 : A 20 kW, 400 V, 3-phase induction motor has full-load power factor of 0.86 and full-load efficiency of 0.88. With stator winding in delta, short-circuit line current at 200 V is 70 A. If this motor is fitted with a star-delta starter, find:

(a) The ratio of starting to full-load current and

(b) The starting torque in terms of full-load torque, for a full load slip of 5%.

(JNTU Jan2012)

Solution: $V_L = 400 \text{ V}$, $\cos\phi = 0.86$, $\eta = 0.88$, $P_{\text{out}} = 20 \text{ Kw}$

$$P_{\text{in}} = \sqrt{3} V_L I_L \cos\phi \text{ and } P_{\text{in}} = P_{\text{out}}/\eta$$

$$(20 \times 10^3)/0.8 = \sqrt{3} \times 400 \times I_L \times 0.86 \text{ i.e. } I_L = 38.14 \text{ A} \quad \dots\dots\text{F.L. line current}$$

short circuit line current is 70 A at 200 V hence

short circuit line current at 400 V rated voltage is $(400/200) \times 70 = 140 \text{ A}$

$$\therefore \text{Phase value of short circuit current} = 140/\sqrt{3} \text{ A}$$

When connected in star, the current further reduces by the factor $1/\sqrt{3}$ A

$$\therefore I_{\text{st}}(\text{ph}) = (1/\sqrt{3}) I_{\text{sc}}(\text{ph}) = (1/\sqrt{3}) \times (140/\sqrt{3}) = 46.667 \text{ A}$$

a) As the motor is star connected at start, the line value of starting current is same as the phase value hence $I_{\text{sc}}(\text{line}) = 46.667 \text{ A}$

$$\therefore I_{\text{st}}(\text{line})/I_{\text{FL}}(\text{line}) = 46.667/38.14 = \mathbf{1.2235}$$

b) $s_{\text{fl}} = 0.05$

$$T_{\text{st}}/T_{\text{fl}} = \mathbf{1/3(I_{\text{sc}}/I_{\text{FL}})^2 s_{\text{fl}}} = 1/3 \times (1.2235)^2 \times 0.05 = \mathbf{0.0249}$$

$$\therefore T_{\text{st}} = \mathbf{2.49\%} \text{ of full load torque.}$$

Example 2 : A 15 kW, 400 V, 950 RPM , 3 phase, 50 Hz, 6 pole Cage motor with 400 V applied takes 6 times full load current at standstill and develops 1.8 times the full load running torque. The full load current is 32 A.

a) What voltage must be applied to produce full load torque at starting?

b) What current will this voltage produce? (JNTU April 2011)

Solution: $P_{\text{out}} = 15 \text{ kW}$, $N = 950 \text{ RPM}$, $f = 50 \text{ Hz}$, $p = 6$, $V = 400 \text{ V}$

$$N_s = 120f/P = (120 \times 50/6) = 1000 \text{ RPM} , s_{\text{fl}} = N_s - N/N_s = 0.05 \text{ (slip)}$$

Current at standstill $I_{\text{sc}} = 6 I_{\text{fl}}$, $I_{\text{fl}} = 32 \text{ A}$

Standstill torque = $1.8 \times T_{\text{fl}}$

a) For $T_{\text{st}} = 1.8 T_{\text{fl}}$, $V = 400 \text{ V}$ and we want V for $T_{\text{st}} = T_{\text{fl}}$

We know that $T \propto E^2 \propto V^2$ as $E \propto V$

$$\therefore 1.8 T_{\text{fl}}/T_{\text{fl}} = (400/V)^2$$

i.e. $V = 400/\sqrt{1.8} = 298.142 \text{ V}$

b) Currents are proportional to applied voltage.

At start, $6I_{fl} \propto 400$ and $I \propto 298.142$

$$\therefore 6I_{fl}/I = 400/298.142 \text{ and } I_{fl} = 32 \text{ A}$$

$$\therefore I = (6 \times 32 \times 298.142)/400 = 143.108 \text{ A}$$

Example 3: The short circuit line current of a 6 HP IM is 3.5 times its full load Current, the stator of which is arranged for Star - Δ starting. The supply voltage is 400 V, full load efficiency is 82 % and full load power factor is 0.85. Calculate the line current at the instant of starting. Neglect magnetising current. (JNTU April/May 2009)

Solution: $I_{sc} = 3.5 I_{fl}$ Starter is Star-delta starter and hence $x = \frac{1}{\sqrt{3}}$

$$V_L = 400\text{V}, \% \eta = 82 \%, \cos\phi = 0.85, P_{out} = 6 \text{ HP}$$

$$\therefore P_{in} = \frac{P_{out}}{\eta} = \frac{6 \times 735.5}{0.82} = 5381.7073 \text{ W}$$

$$P_{in} = \sqrt{3}V_L I_L \cos\phi \text{ i.e. } I_L = \frac{5381.7073}{\sqrt{3} \times 400 \times 0.85} = 9.1386 \text{ A}$$

$$\therefore I_{fl} = I_L = 9.1386 \text{ A}$$

$$\therefore I_{st} = x^2 I_{sc} = \frac{1}{3} \times 3.5 I_{fl} = \frac{1}{3} \times 3.5 \times 9.1386 = 10.6617 \text{ A}$$

Example 4: A 110 V, 3- ϕ , star connected IM takes 25 A at a line voltage of 30 V with rotor blocked. With this line voltage, input power to motor is 440 W and core loss is 40 W. The d.c. resistance between a pair of stator terminals is 0.1 Ω . If the ratio of a.c. to d.c. resistance is 1.6. Find the equivalent leakage reactance per phase of motor and the stator and rotor resistance per phase. (JNTU Jan 2009)

Solution: $V_{sc} (\text{line}) = 30 \text{ V}, I_{sc} = 25 \text{ A}, \text{ Star connection}$

$$\therefore Z_{1e} = \frac{V_{SC} (\text{Ph})}{I_{SC} (\text{Ph})} = \frac{(30\sqrt{3})}{25} = 0.6928 \Omega/\text{ph}$$

$$[\text{Stator} + \text{Rotor copper losses}] = \text{Input} - \text{Core loss} = 440 - 40 = 400\text{W}$$

$$\therefore 3 \times I_{SC}^2 \times R_{1e} = 400 \quad \text{i.e.} \quad R_{1e} = \frac{400}{3 \times 25^2} = 0.2133 \Omega/\text{ph}$$

$$\therefore X_{1e} = \sqrt{Z_{1e}^2 - R_{1e}^2} = 0.6591 \Omega/\text{ph}$$

$$\text{D.C. resistance / ph of stator} = \frac{0.1}{2} = 0.05 \Omega$$

$$\therefore \text{A.C. resistance / ph} = 1.6 \times 0.05 = 0.08 \Omega$$

$$\therefore R_1 = 0.08 \Omega, R_2 = R_{1e} - R_1 = 0.2133 - 0.08 = 0.1333 \Omega$$

Example 5: A 400 V, 50 Hz, three-phase induction motor takes a starting current of 75 A and develops a starting torque of 1.5 times its full-load torque when full voltage is supplied across the winding terminals connected in delta. Calculate the starting line current and starting torque if the motor windings are connected in star and full voltage is applied across its terminals.

Solution:

Current taken when delta connected = 75 A

We know that current taken when star connected is 1/3 times the current drawn when connected in Delta.

Hence Current taken when star connected = 75/3 = 25 A

We know that Torque T is proportional to the square of voltage. We also know Voltage applied per phase when star-connected is 1/√3 times the voltage applied when windings are delta-connected. Since torque is proportional to square of the applied voltage, starting torque with windings star-connected will be one-third of the starting torque with windings delta connected.

Starting torque with windings delta-connected = 1.5 × T_{FL}

Starting torque with windings star-connected = (1.5 × T_{FL})/3 = 0.5 × T_F

Important questions:

1. (a) With a clear test setup explain how No load and Blocked Rotor tests are conducted on an Induction Motor (b) Explain how the data obtained from these experiments is used to predetermine the efficiency of an Induction Motor at any load.
2. Explain the necessity and basic principle of operation of Starters in Induction Motors
3. Explain with the help of diagrams the operation of the following types of starters. Derive the Relation between T_{ST} and T_{FL} for all these starters.
a) Stator Resistance Starter b) Auto Transformer Starter c) Rotor Resistance Starter d) Direct On Line (DOL) Starter e) Star- Delta Starter
4. (a) Explain the basic principle of Speed control of Induction Motors from the fundamental performance equations and outline the possible methods both from Stator side and Rotor side.
5. Explain in detail along with Torque speed characteristics speed control of Induction Motors with variable frequency method. Elaborate why constant V/f is required below base speed and not required above base speed.
6. Explain Speed control of IMs with variable Stator Voltage method
7. Explain Speed control of Slip ring Induction Motors by changing Rotor resistance with torque speed characteristics.
8. Explain Speed control of IMs with Change of poles methods both (i) Two Separate Windings on the Stator and (ii) Consequent-pole Technique
9. Explain Cascade control of two Induction Motors
10. Explain how speed control of IMs is achieved by Injection of an e.m.f into rotor circuit (both Kramer and Scherbius drives).
11. Explain how an Induction Generator works and the two methods of excitation.
12. All the above Illustrative examples

UNIT-III SYNCHRONOUS MACHINES

- Introduction
- Constructional Features of round rotor and salient pole machines
- Armature windings
- Integral slot and fractional slot windings
- Distributed and concentrated windings
- Distribution, pitch and winding factors
- E.M.F Equation.
- Armature reaction, leakage reactance, synchronous reactance and impedance - Experimental determination
- Equivalent Circuit & Phasor diagrams
- Load characteristics & Voltage regulation .
- Regulation by synchronous impedance method, M.M.F. method and Z.P.F. method
 - Illustrative examples
 - Important questions

Introduction:

The most commonly used machine for generation of electrical power for commercial applications is the synchronous generator. Such a synchronous generator is also called an alternator since it generates alternating voltage. A Synchronous Machine has two main parts, viz. the stator and the rotor just like a DC Machine or an Induction Machine

Synchronous Machine Vs Induction Machine:

There are two major types of AC machines: Synchronous machines and Induction machines. In both of them:

A three-phase system of currents supplied to a system of three coils spaced 120 degrees apart on a stator will produce a uniform rotating magnetic field within the stator. The *direction of rotation* of the magnetic field can be *reversed* by simply swapping the connections to any two of the three phases. This is the working principle of both Induction and Synchronous Motors. Conversely, a rotating magnetic field will produce a three-phase set of voltages within such a set of coils. This is the working principle of both Induction and Synchronous generators.

The principal difference between the two types is that synchronous machines require a DC field current to be supplied to their rotors, while induction machines have the field current induced in their rotors by transformer action.

In both Synchronous and Induction machines the speed of the rotating magnetic field & electrical frequency and electrical phase angle & mechanical angle are related to the number poles in the machines are related the same way as below.

In stators of more than two poles, one complete mechanical rotation of the magnetic field produces more than one complete electrical cycle. For such a stator, one mechanical rotation produces $P/2$ electrical cycles. Therefore, the electrical angle of the voltages and currents in such a machine is related to the mechanical angle of the magnetic fields by:

$$\theta_e = (P/2)\theta_m$$

The relationship between the electrical frequency of the stator and the mechanical rate of rotation of the magnetic fields is given by: $f_e = PN_m / 12$

Synchronous Generator Vs. DC Generator:

We know that in the case of a DC Generator basically the type of induced e.m.f generated in the armature conductors is AC only. It is converted to DC by using commutator. If they are removed and the voltage available from the armature conductors is directly collected, then the output would be AC only. Such a machine without commutator which provides AC output is called an Alternator. But in the case of an alternator to draw the AC output Slip rings and Brushes are used. Further in the case of Synchronous Generator three armature windings spatially separated by 120° are placed in the Stator.

Basic principle of operation of a Synchronous Generator:

In a synchronous generator, a DC current is applied to the rotor winding, which produces a rotor magnetic field. The rotor of the generator is then turned by a prime mover, producing a rotating magnetic field within the machine. This rotating magnetic field induces a three-phase set of voltages within the stator windings of the generator.

Two terms commonly used to describe the windings on an Electric Machine are '**field windings**' and '**armature windings**'. In general, the term "field windings" applies to the windings that produce the main magnetic field in a machine, and the term "armature windings" applies to the windings where the main voltage is induced.

For synchronous machines, the field windings are on the rotor, so the terms "**rotor windings**" and "**field windings**" are used interchangeably. Similarly, the terms "**stator windings**" and "**armature windings**" are used interchangeably.

Constructional details of a three phase Synchronous Machine:

A synchronous machine works as a generator when the rotor is rotated and as a motor when a three-phase supply is connected across its armature. The basic construction of a synchronous generator and a synchronous motor is the same. In a dc machine, the field system is stationary and the armature winding is placed on the rotor. The same arrangement can be done in a synchronous machine also. But

in a synchronous machine, due to a number of advantages, the field system is made rotating and the armature winding is placed in stator slots. These two

possible arrangements of armature and field system are shown in the figure below.

In synchronous machine construction, two arrangements are possible: the arrangement shown in figure (a) below in which the field is stationary and the armature is rotating has limited applications. In almost all commercial synchronous machines, rotating field and stationary armature system as shown in figure (b) is used for the following reasons.

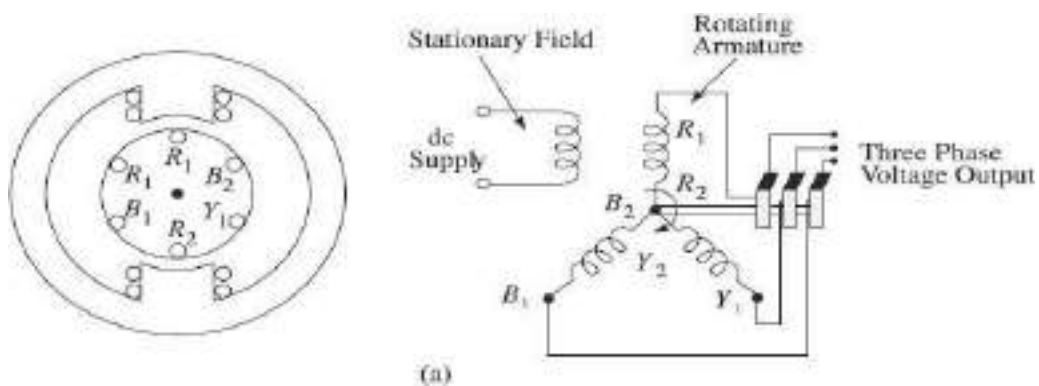

(a) Stationary field and rotating armature system as in a DC machine,

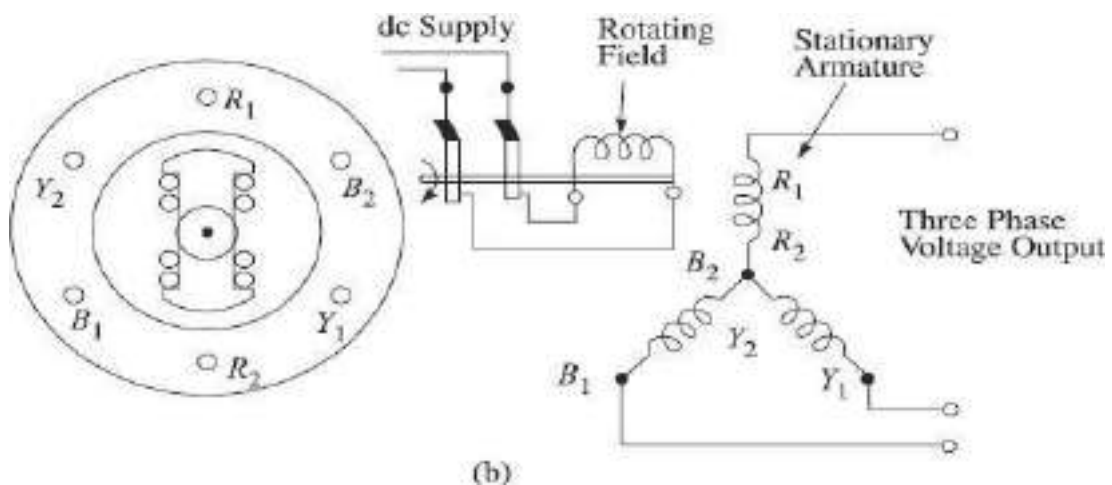

(b) Rotating field and stationary armature system as in an alternator

Advantages of Rotating Field and Stationary Armature System:

The following are the main reasons why a stationary armature and rotating field

construction for three-phase synchronous machines is used in all commercial applications.

(a) Ease of Construction: For large three-phase synchronous machines, the armature winding is more complex than the field winding. The coil and phase connections of the windings can be done more easily and securely on a stationary structure, i.e., on the stator than on the rotor.

(b) Number of Slip-rings required: Referring to the figure (a) above it is seen that when armature winding is made rotating, at least three slip-rings are needed to receive the generated power for the output circuit from the synchronous generator. For large synchronous machines rated in MVAs and voltage ratings in kilo volts (generally 11 kV) transferring power through brush and slip-ring arrangement is very difficult. It is also difficult to insulate the slip-rings from the rotating shaft for high voltage. The distance between the slip-rings is to be kept sufficiently large so that flash-over does not take place.

With the stationary armature and rotating field arrangement, none of these problems occur. Only two slip-rings of much smaller size are required to supply excitation current to the rotating windings, as power required for excitation is much less and is supplied at a low voltage.

(c) Better Insulation to Armature: Large size commercial synchronous machine armature coils carry heavy currents at high voltage. It is easier to insulate the armature coils from the core, if the windings are placed on the stator instead of on the rotor. It is comparatively easier to insulate the low voltage DC winding placed on the rotor.

(d) Reduced Rotor Weight and Rotor Inertia: The weight of the field system placed on the rotor is comparatively much lower than the armature winding placed on the stator. This is because the field windings are made with thinner wires and are required to be insulated for a lower voltage. The inertia of the rotor is, therefore reduced. With rotating field system, the rotor will take comparatively less time to come up to the rated speed.

Hence all the large synchronous machines built today have stationary armature and rotating field structure as shown in the figure (b) above.

Types of Rotor Construction:

The rotor of a synchronous generator is essentially a large electromagnet. The

magnetic poles on the rotor can be of either *salient* or *nonsalient* construction.

The term *salient* means "protruding" or "sticking out" and a "*salient pole*" is a magnetic pole that sticks out from the surface of the rotor. On the other hand a *nonsalient pole* is a magnetic pole constructed flush with the surface of the rotor. Both types of rotors are shown in the figures below. Nonsalient-pole rotors are normally used for two- and four-pole rotors, while salient-pole rotors are normally used for rotors with four or more poles. Because the rotor is subjected to changing magnetic fields, it is constructed of thin laminations to reduce eddy current losses.

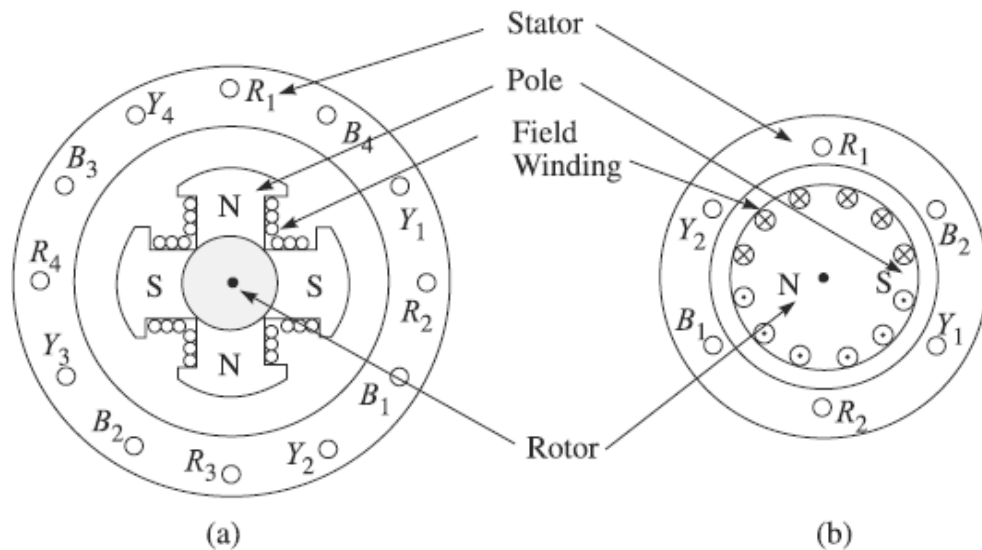

Figure (a) Salient type rotor (b) Non-salient or cylindrical type rotor

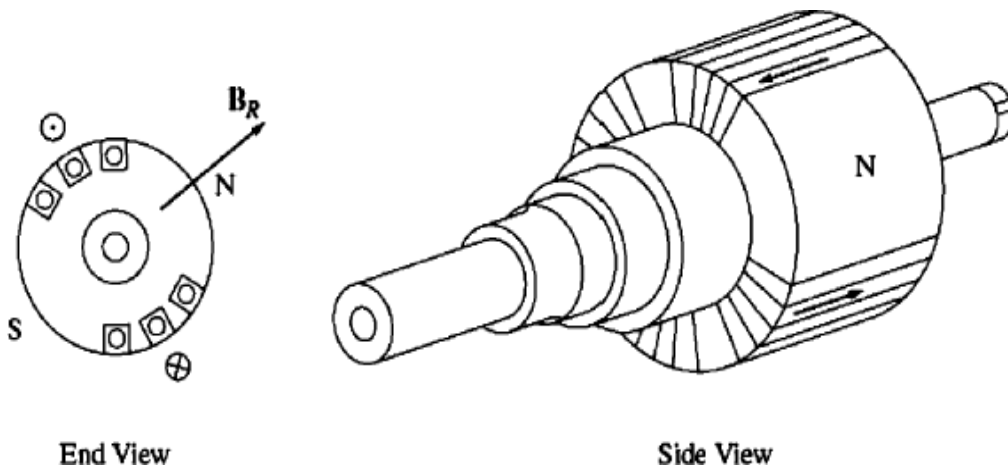

Figure: A Nonsalient two-pole Rotor for a Synchronous machine

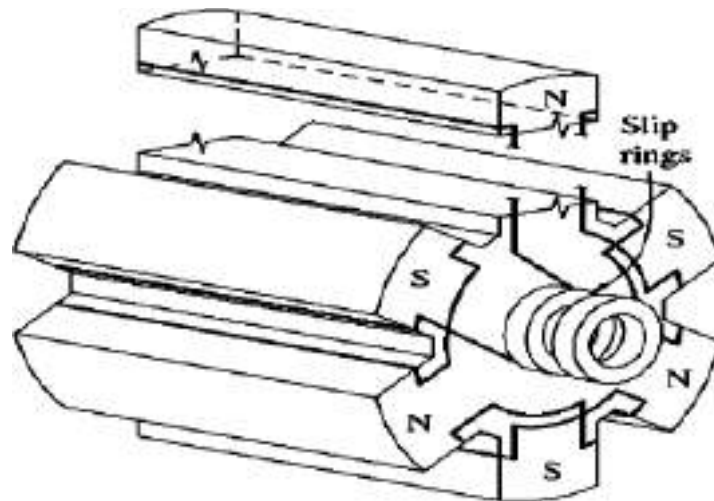

Figure: A Salient Six pole Rotor for a Synchronous Machine

Type of rotor construction also depends upon the type of prime mover used to drive the synchronous generator and is explained in detail below. .

Salient Type Rotor for Alternators Driven at Low Speeds

Alternators driven at low speeds by prime movers like water turbines will have salient pole rotors. This is because, to generate electricity at 50 Hz with the rotor rotate at slow speeds, the number of rotor poles required becomes large. It is convenient to build a rotor having large number of poles in projected pole, i.e., salient pole construction. The diameters of such rotors become bigger than their lengths.

Nonsalient Type Rotor for Alternators Driven at High Speeds

For alternators using high-speed turbines (3000 rpm) like steam turbines as Prime movers, the number of rotor poles required to generate electricity at 50 Hz is only two. To reduce the centrifugal force developed on the rotor winding at high-speed, the rotor diameter is to be kept small. Nonsalient, i.e., cylindrical type rotor construction is made for such synchronous generators. The length of such

generators is more than their diameters. For alternators using medium-speed

prime mover, like diesel engines, the number of rotor poles is more than two and the rotor is made salient type.

Excitation for Rotating Field System:

A DC current must be supplied to the field circuit on the rotor. Since the rotor is rotating, a special arrangement is required to get the DC power to its field windings. There are two common approaches to supplying this DC power:

1. Supply the DC power from an external DC source to the rotor by means of *slip rings* and *brushes*. This is used for small size generators.
2. Supply the DC power from a special DC power source mounted directly on the shaft of the synchronous generator thus avoiding slip rings and brushes totally. This is called *Brush less exciter* and used for large size Generators.

Brushless exciter: It is a small AC generator with its Field circuit mounted on the stator and its Armature circuit mounted on the rotor shaft as shown in the figure below.

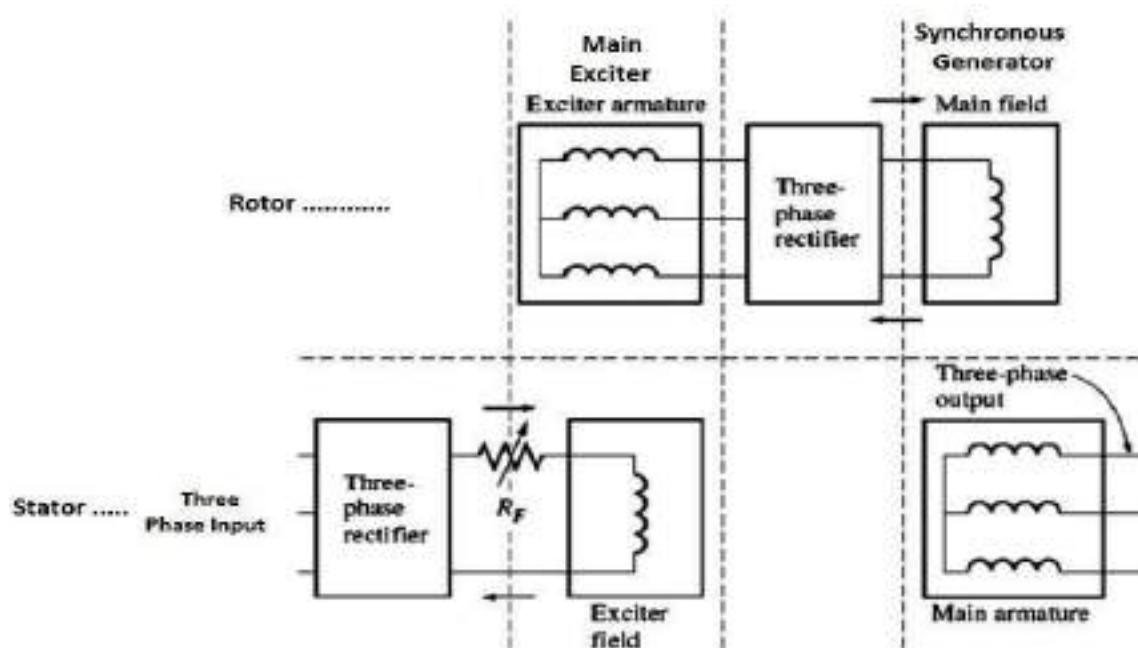

Figure: A brush less exciter circuit. A small three-phase current is rectified and

used to supply the field circuit of the exciter which is located on the stator. The output of the armature circuit of the exciter (on the rotor) is then rectified and used to supply the field current of the main machine

The three-phase output of the exciter generator is rectified to direct current by a three-phase rectifier circuit also mounted on the shaft of the generator, and is then fed into the main DC field circuit. By controlling the small DC field current of the exciter generator (located on the stator), it is possible to adjust the field current on the main machine *without slip rings and brushes*.

A Synchronous machine rotor with a brushless exciter mounted on the same shaft is shown in the figure below. Since no mechanical contacts ever occur between the rotor and the stator, a brushless exciter requires much less maintenance than an exciter with slip rings and brushes.

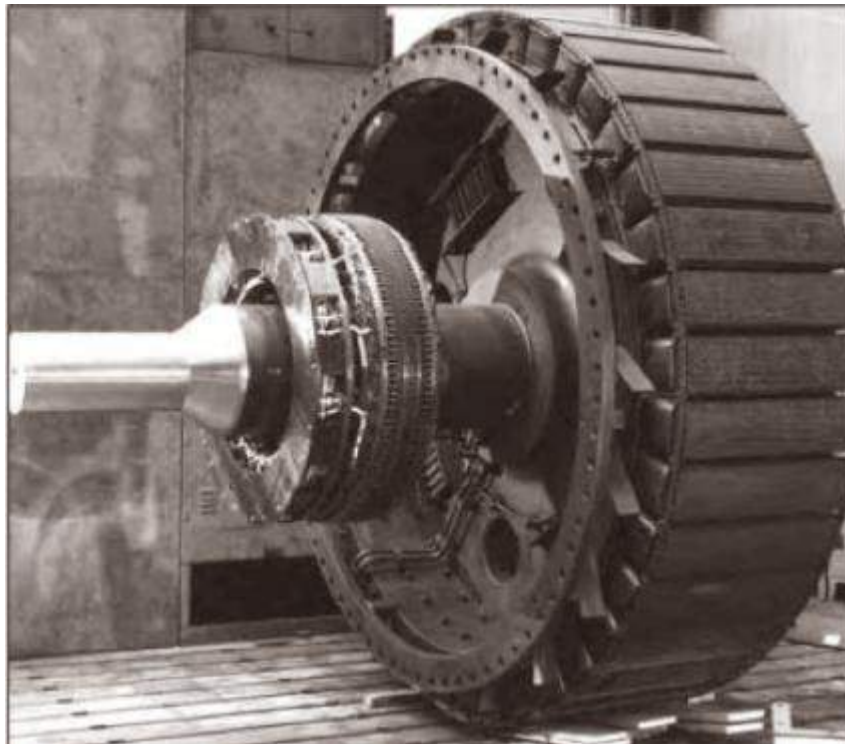

Figure: Photograph of a synchronous machine rotor with a brush less exciter mounted on the same shaft. Notice the rectifying electronics visible next to the armature of the exciter.

Brush less exciter with a Pilot exciter: To make the excitation of a generator *completely* independent of any external power sources, a small pilot exciter is

often included in the system. A *pilot exciter* is a small ac generator with *permanent magnets* mounted on the rotor shaft and a three-phase winding on

the stator as shown in the figure below. It produces the power for the field circuit of the exciter, which in turn controls the field circuit of the main machine. If a pilot exciter is included on the generator shaft, then *no external electric power* is required to run the generator.

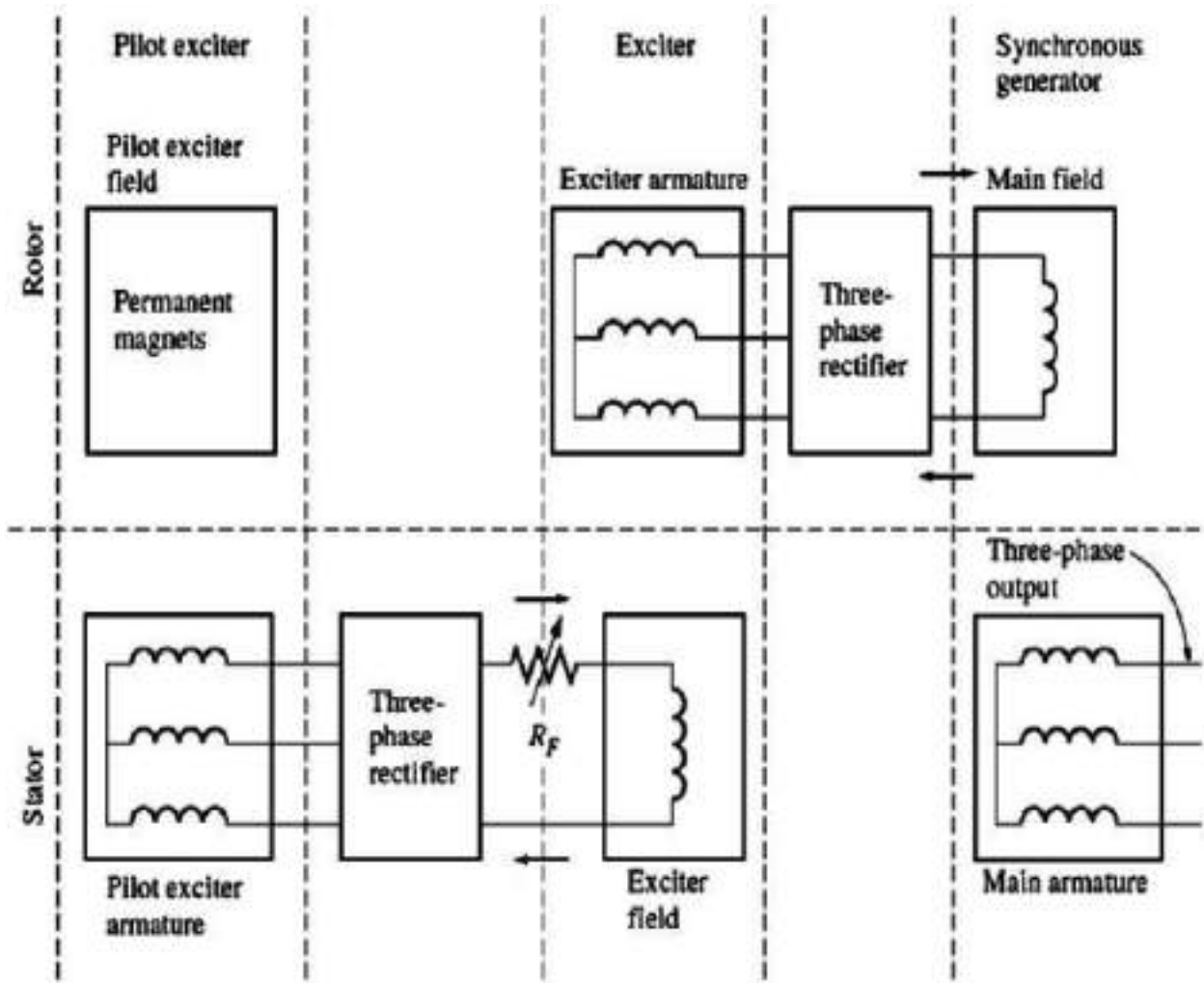

Figure: A brushless excitation scheme that includes a pilot exciter. The permanent magnets of the pilot exciter produce the field current of the exciter which in turn produces the field current of the main machine.

A cutaway diagram of a complete large synchronous machine is shown in the

figure below. This figure shows an eight-pole salient-pole rotor, a stator with distributed double-layer windings, and a brushless exciter.

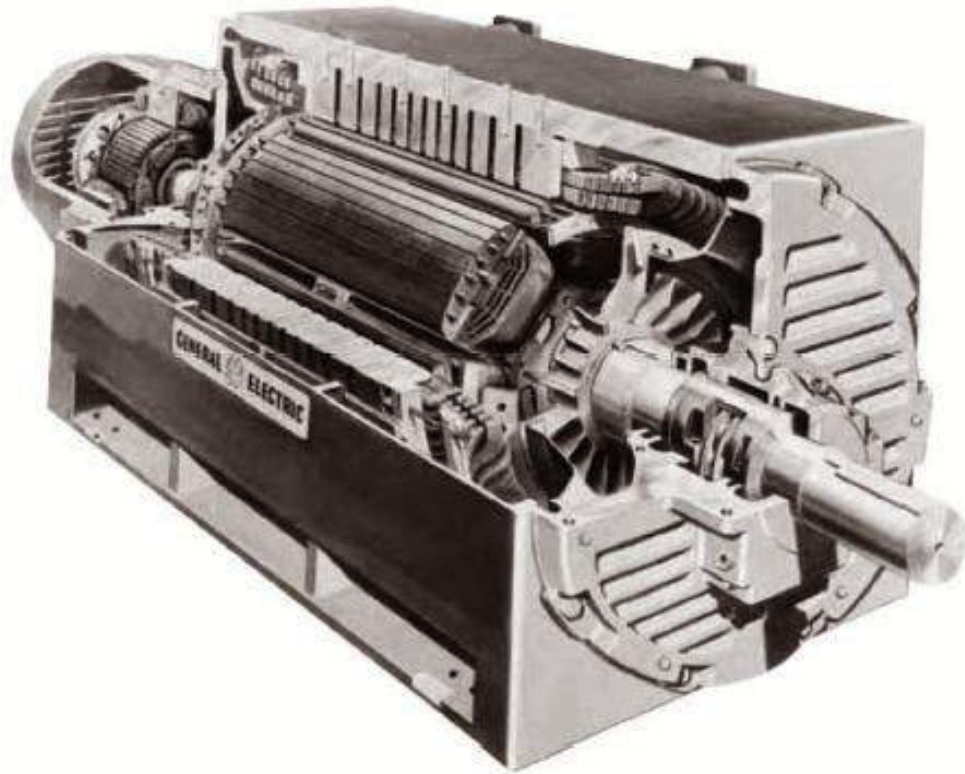

Figure: A cutaway diagram of a large synchronous machine. Note the salient pole construction and the onshaft exciter.

Armature Winding

Armature winding of alternators is different from that of DC machines. Basically, three phase alternators carry three sets of windings arranged in the slots in such a way that there exists a Phase difference of 120° between the induced e.m.f.s in them. In D.C machine, Winding is closed while in alternators winding is open i.e. two ends of each set of winding is brought out. In three phase alternators, the six terminals are brought out which are finally connected in star or delta and then the three terminals are brought out. Each set of windings represents winding per phase and induced e.m.f. in each set is called induced e.m.f. per phase denoted as E_{ph} . All the coils used for one phase must be connected in such a way that their e.m.f.s add to each other. And overall design should be in such a way that the

waveform of an induced e.m.f. is almost sinusoidal in nature.

Winding Terminology

1) Conductor: The part of the wire, which is under the influence of the magnetic field and responsible for the induced e.m.f. is called a conductor and its length is called active length of the conductor. The conductors are placed in the armature slots.

2) Turn: A conductor in one slot, when connected to a conductor in another slot forms a turn. So two conductors constitute one turn. This is shown in the figure below.

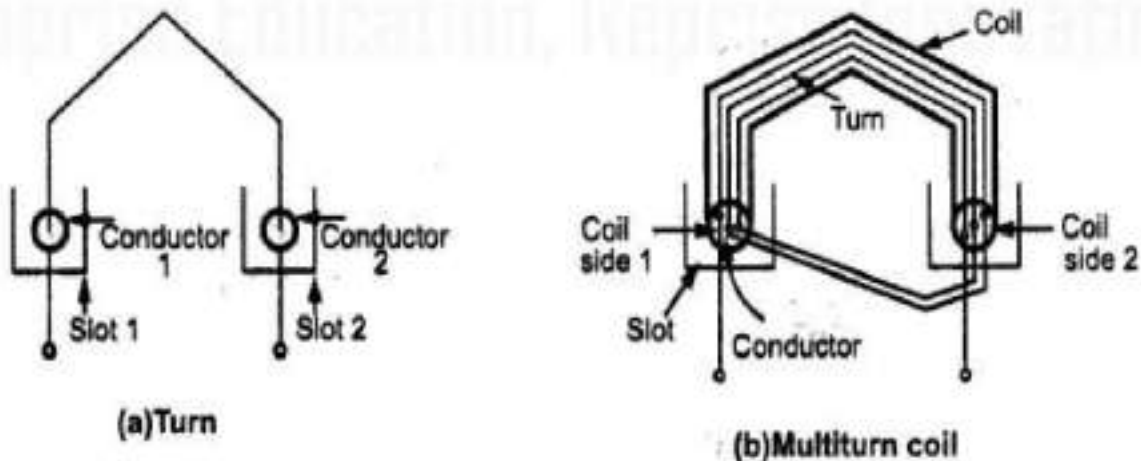

3) Coil: As there are number of turns, they are all grouped together to form a coil. Such a coil is called multiturn coil. A coil may consist of a single turn in which case it is called a single turn coil. Figure (b) above shows a multiturn coil.

4) Coil Side: Since coil consists of many turns part of the coil in each slot is called coil side of a coil as shown in the figure (b) above.

5) Pole pitch: It is the *centre to centre* distance between the two adjacent poles measured in terms of number of slots or electrical degrees. We have seen that for one rotation of the conductor, 2 poles are responsible for 360° of electrical induced emf, 4 poles are responsible for 720° and so on. So, 1 pole is responsible for 180° electrical in induced e.m.f.

Practically how many slots are under one pole which are responsible for 180° electrical voltage are measured to specify the pole pitch.

e.g., Consider 2 pole, 18 slots armature of an alternator. Then under 1 pole there

are $18/2$ i.e., 9 slots. So, pole pitch is 9 slots or 180° electrical. This means 9 slots are responsible to produce a phase difference of 180° between the e.m.f.s. induced in different conductors.

$$\begin{aligned} \text{Pole pitch} &= 180^\circ \text{ electrical} \\ &= \text{slots per pole (no. of. Slots/P)} = n \end{aligned}$$

6) Slot angle (β): The phase difference contributed by one slot in degrees electrical is called slot angle β . As the number of slots per pole which contribute to a phase of 180° is denoted by 'n', slot angle $\beta = 180^\circ/n$

In the above example, $n = 18/2 = 9$ and so slot angle $\beta = 180^\circ/n = 180^\circ/9 = 20^\circ$

This means that if we consider the induced e.m.f. in the conductors which are placed in the slots which are adjacent to each other, there exists a phase difference of β° in between them. Similarly e.m.f. induced in the conductors which are placed in slots which are 'n' slots distance away, there exists a phase difference of 180° between them.

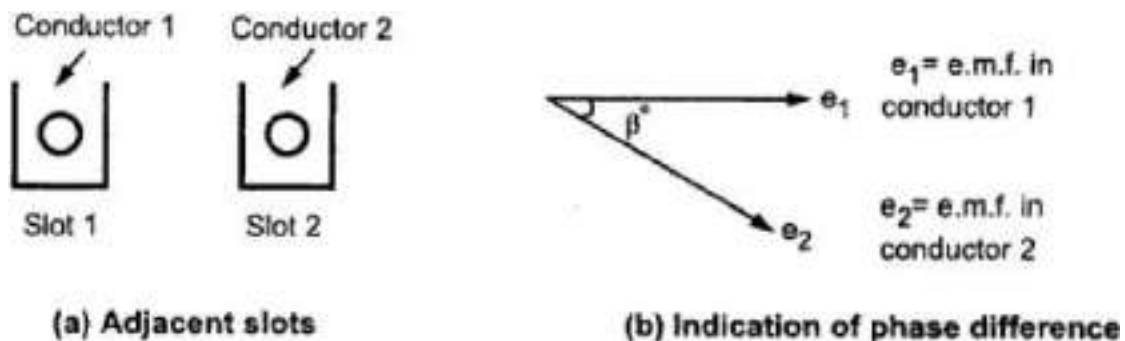

Types of Armature Windings:

In general armature windings are classified as:

1. Single layer and double layer winding
2. Full pitch and short pitch winding.
3. Concentrated and distributed winding.

Single Layer and Double Layer Winding

If a slot consists of only one coil side as shown in the figure (a) below the winding is said to be single layer. If there are two coil sides per slot, one at the bottom

and one at the top as shown in the figure (b) below, the winding is called double layer winding.

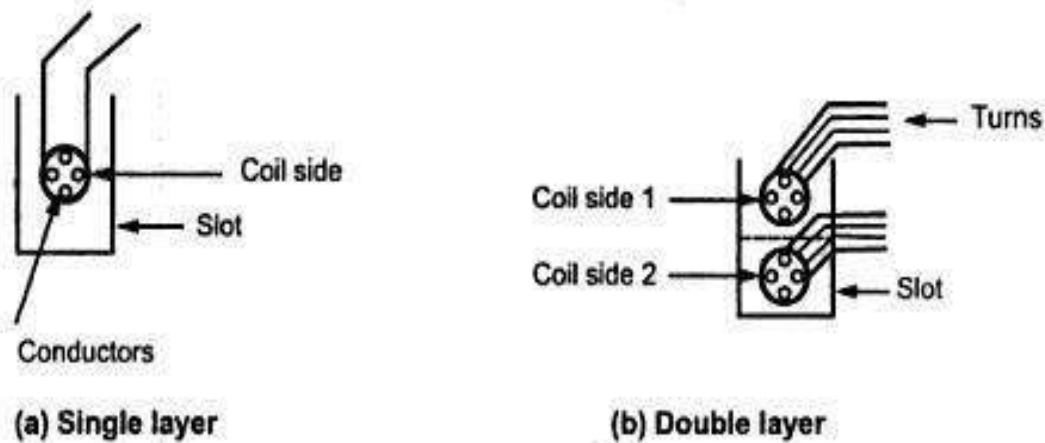

A lot of space gets wasted in single layer windings and hence in practice generally double layer winding is only preferred.

Full Pitch and Short Pitch Winding

As seen earlier, one pole pitch is always 180° electrical. The value of 'n', slots per pole indicates how many slots are contributing to 180° of electrical phase difference. So, if coil side in one slot is connected to a coil side in another slot which is one pole pitch distance away from first slot, the winding is said to be full pitch winding and coil is called full pitch coil.

For example, in a 2 pole, 18 slots alternator, the pole pitch is $n = 18/2 = 9$ slots. So, if coil side in slot No. 1 is connected to coil side in slot No. 10 such that two slots No. 1 and No. 10 are one pole pitch or n slots or 180° electrical apart, the coil is called full pitch coil. Here we can define one more term related to a coil called coil span.

Coil Span

It is the distance on the periphery of the armature between two coil sides of a coil. It is usually expressed in terms of number of slots or degrees electrical. So, if coil span is 'n' slots or 180° electrical the coil is called full pitch coil. This is shown in the figure below.

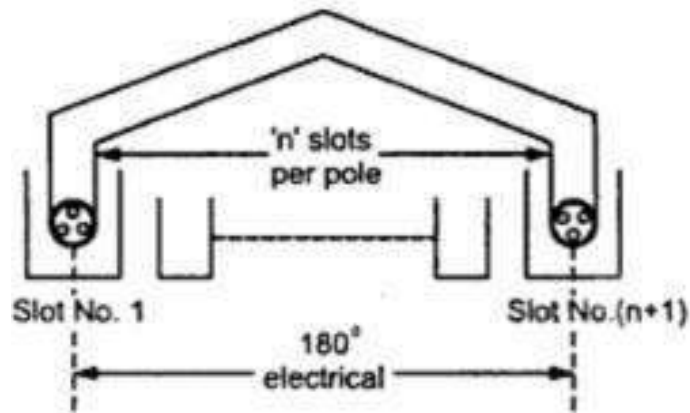

Figure: Full pitch coil

As against this if coils are used in such a way that coil span is slightly less than a pole pitch i.e., less than 180° electrical, the coils are called, **short pitched coils** or **fractional pitched coils**. Generally, coils are shorted by one or two slots

So, in 18 slots, 2 pole alternator instead of connecting a coil side in slot No. 1 to slot No.10, it is connected to a coil side in slot No.9 or slot No. 8, coil is said to be short pitched coil and winding is called short pitch winding. This is shown in the figure below.

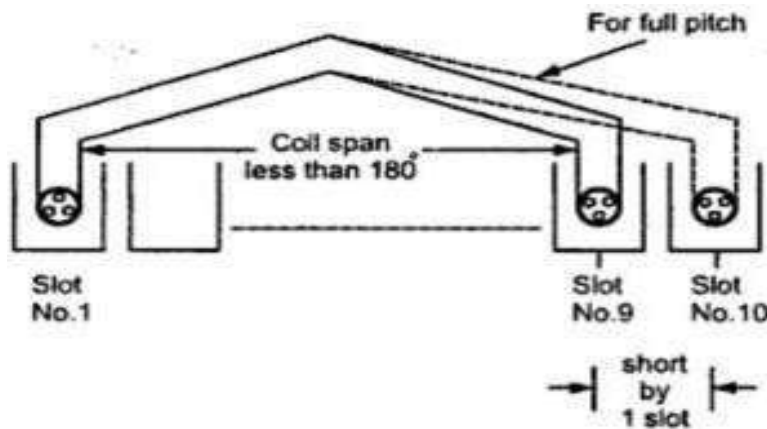

Figure: Short pitch coil

Advantages of Short Pitch Coils:

In actual practice, short pitch coils are used as it has the following advantages:

-
- The length required for the end connections of coils is less i.e., inactive length of winding is less. So, less copper is required. Hence economical.
 - Short pitching eliminates high frequency harmonics which distort the sinusoidal nature of e.m.f. Hence waveform of induced e.m.f is more sinusoidal due to short pitching.
 - As high frequency harmonics get eliminated, eddy current and hysteresis losses which depend on frequency also get minimised. This increases the efficiency.

Concentrated and Distributed Winding:

Concentrated winding: In three phase alternators, we know that there are three different sets of windings, one for each phase. So, depending upon the total number of slots and number of poles, we have certain slots per phase available under each pole. This is denoted as ' m '.

' m ' = Slots per pole per phase = $n/\text{number of phases}$
 = $n/3$ (since generally no. of phases is 3)

For example, in 18 slots, 2 pole alternator we have, $n = 18/2 = 9$ and hence
 $m = 9/3 = 3$

So, we have 3 slots per pole per phase.

Now let ' x ' be the number of conductors per phase which are to be placed under one pole. And we have 3 slots per pole per phase available. But if all ' x ' conductors per phase are placed in one slot keeping remaining 2 slots per pole per phase empty then the winding is called **concentrated winding**.

So in concentrated winding all conductors or coils belonging to a phase are placed in one slot under every pole.

Distributed winding: But in practice, an attempt is always made to use all the ' m ' slots per pole per phase available for distribution of the winding. So, if all the ' x ' conductors per phase are distributed amongst the 3 slots per phase available under every pole, the winding is called **distributed winding**. So, in distributed winding all the coils belonging to a phase are distributed over all the ' m ' slots per phase available under every pole. Distributed winding makes the waveform of the induced e.m.f more sinusoidal in nature. Also, in concentrated winding due to

large number of conductors per slot, heat dissipation is poor.

So, in practice, double layer, short pitched and distributed type of armature windings are used in the alternators.

Integral Slot Winding

The value of 'm' = slots/ pole / phase decides the class of the winding. *When the value of 'm' is an integer, then the winding is called **Integral slot winding**.*

Consider a 2 pole, 12 slots alternator: $n = \frac{\text{slots}}{\text{pole}} = \frac{12}{2} = 6$

Then Pole pitch = $180^\circ = 6$ slots and 'm' = $\frac{n}{3} = \frac{6}{3} = 2$

As 'm' is integer, this type of winding is known as '**Integral slot winding**'. This winding can be full pitch winding or short pitch winding.

Fractional Slot Winding

This is another class of winding which depends on the value of 'm'. *The winding in which **slots per pole per phase (m)** is a fractional number is called fractional slot winding.* In such a winding, the number of slots (S) must be divisible by 3. Thus, the number of slots per phase is an integer which is necessary to obtain symmetrical three phase winding. But slots per Pole (n) and slots per pole per phase (m) both are fractional. As 'n' is a fraction, the coils cannot be full Pitch. Thus, if there are 54 slots and 8 poles then the slots per pole $n = 54/8 = 6.75$ hence coil Span can be 7 or 6. Generally short pitch coils are used. Such a fractional slot winding can be easily achieved with double layer winding.

Advantages of Fractional Slot Winding:

1. Though appear to be complicated, easy to manufacture.
 2. The number of armature slots (S) need not be integral multiple of number of poles (P).
 - 3 The number of slots can be selected for which notching gear is available, which is economical.
 4. There is saving in machine tools.
-

-
5. High frequency harmonics are considerably reduced.
 6. The voltage waveform available is sinusoidal in nature.

E.M.F. Equation of an Alternator:

Let Φ = Flux per pole, in Wb

P = Number of poles

N_s = Synchronous speed in r.p.m.

f = Frequency of induced e.m.f in Hz

Z = Total number of conductors

Z_{ph} = Conductors per phase connected in series

$Z_{ph} = Z/3$ as number of phases = 3.

Let us consider a single conductor placed in a slot.

The average value of e.m.f induced in a conductor = $\frac{d\phi}{dt}$

For one revolution of a conductor,

$$e_{avg} \text{ per conductor} = \frac{\text{Flux cut in one revolution}}{\text{Time taken for one revolution}}$$

Total flux cut in one revolution is $\phi \times P$.

Time taken for one revolution is $(60/N_s)$ seconds.

$$e_{avg} \text{ per conductor} = \frac{\phi P}{\left(\frac{60}{N_s}\right)} = \phi \frac{PN_s}{60} \quad \dots (1)$$

But we know that ' f ' = $(PN_s/120)$

Hence $(PN_s/60) = 2f$

Substituting this in equation (1),

e_{avg} per conductor = $2f\Phi$ volts

Assuming full pitch winding for simplicity i.e., this conductor is connected to a conductor which is 180 electrical apart. So, these two e.m.f.s will try to set up a current in the same direction i.e., the two e.m.f. are helping each other and hence resultant e.m.f. per turn will be twice the e.m.f. induced in a conductor.

Then e.m.f. per turn = $2 \times (\text{e.m.f. per conductor}) = 2 \times (2f\Phi) = 4 f\Phi$ volts.

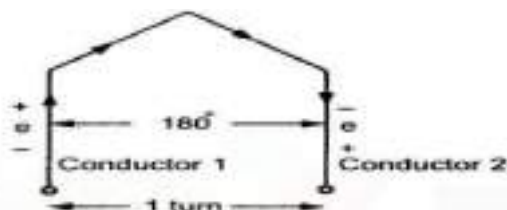

Figure: One Turn of full pitch coil

Let ' T_{ph} ' be the total number of turns(= $Z_{ph}/2$) per phase connected in series. Assuming **concentrated winding**, we can say that all are placed in single slot per pole per phase. So induced e.m.f.s in all turns will be in phase as they are placed in a single slot. Hence the net e.m.f per phase will be algebraic sum of the e.m.f. s per turn.

$$\therefore \text{Average } E_{ph} = T_{ph} \times (\text{Average e.m.f. per turn})$$

$$\therefore \text{Average } E_{ph} = T_{ph} \times 4 f \Phi$$

But in a.c. circuits R.M.S. value of an alternating quantity is used for the analysis. The form factor $K_f(\text{RMS}/\text{Average}) = 1.11$ for sinusoidal parameters.

$$\therefore \text{R.M.S. value of } E_{ph} = K_f \times \text{Average value}$$

$$\therefore E_{phrms} = 1.11 \times 4 f \Phi T_{ph} = 4.44 f \Phi T_{ph} \text{ Volts}$$

This is the basic e.m.f. equation for the induced e.m.f. per phase for 'full pitch', 'concentrated' type of winding

But as mentioned earlier, the winding used for the alternators is ***distributed*** and ***short pitch***. Hence e.m.f induced gets affected. Hence we have to see the effect of ***distributed*** and ***short pitch*** type of windings on the e.m.f. equation.

Pitch factor or Coil Span Factor (K_c):

In practice short pitch coils are preferred. So, coil is formed by connecting one coil side to another which is less than one pole pitch away. So actual coil span is less than 180° . The coil is generally short pitched by one or two slots.

Angle by which coils are short pitched is called angle of short pitch denoted as ' α '. Slot angle is β and the angle of short pitch is always a multiple of the slot angle β .

$$\alpha = \beta \times \text{number of slots by which the coils are short pitched}$$

or $\alpha = 180^\circ$ - Actual coil span of the coils

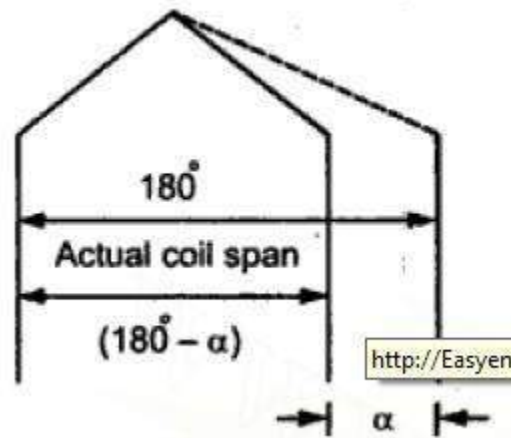

Figure: Angle of short pitch

Derivation of expression for 'Pitch factor or Coil Span Factor (K_c):'

Now let E be the induced e.m.f. in each coil side. If the coil is a full pitch coil, the induced e.m.f. in each coil side help each other. Coil connections are such that both will try to set up a current in the same direction in the external circuit. Hence the resultant e.m.f. across a coil will be algebraic sum of the two.

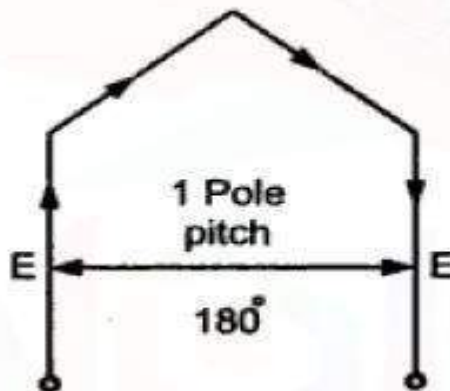

Figure :Full pitch coil

$$\text{Hence } E_R = E + E = 2E$$

But if the coil is short pitched by an angle ' α ', the two e.m.f.s in the two coil sides no longer remain in phase. Hence the resultant e.m.f. also no longer remains

algebraic sum of the two but becomes a phasor sum of the two as shown in the figure below. Obviously, E_R in such a case will be less than what it is in the case of

a full pitched coil ($2E$). From the geometry of the figure below we can show that the resultant e.m.f is given by:

$$E_R = 2 E \cos (\alpha/2)$$

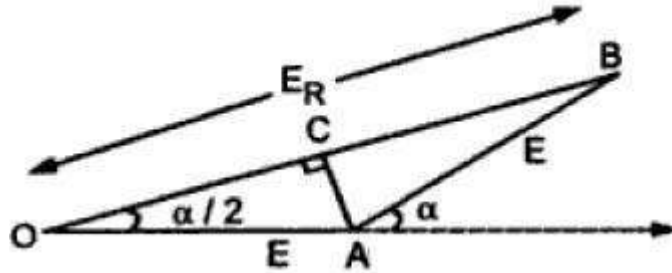

Figure: Phasor sum of the two e.m.fs with a Short pitched coil

Now the factor by which, induced e.m.f in the coil gets reduced due to short pitching is called **pitch factor** or **coil span factor** denoted by K_C . It is defined as the ratio of resultant e.m.f. when coils short pitched to the resultant e.m.f. when coil is full pitched. It is always less than one.

$$\therefore K_C = \frac{E_{R \text{ when coil is short pitched}}}{E_{R \text{ when coil is full pitched}}} = \frac{2 E \cos(\frac{\alpha}{2})}{2 E}$$

$$= K_C = \cos (\alpha/2)$$

Where α = Angle of short pitch

Distribution Factor (K_d)

Similar to full pitch coils, concentrated winding is also rare in practice. Attempt is made to use all the slots available under a pole for the winding which makes the nature of the induced e.m.f. more sinusoidal. Such a winding is called a distributed winding.

Consider **18 slots, 2 pole** alternator. So, **slots per pole** i.e. $n = 9$.

m = Slots per pole per phase = **3**

$$\beta = 180^\circ / 9 = 20^\circ$$

Let E = induced e.m.f per coil and there are 3 coils per phase.

In concentrated type all the coil sides will be placed in one slot under a pole. So induced e.m.f. in all the coils will achieve maxima and minima at the same time i.e., all of them will be in phase. Hence resultant e.m.f. after connecting coils in series will be algebraic sum of all the e.m.fs as all are in phase.

AS against this, in distributed type, coil sides will be distributed, one each in the 3 slots per phase available under a pole as shown in the figure (a) below .

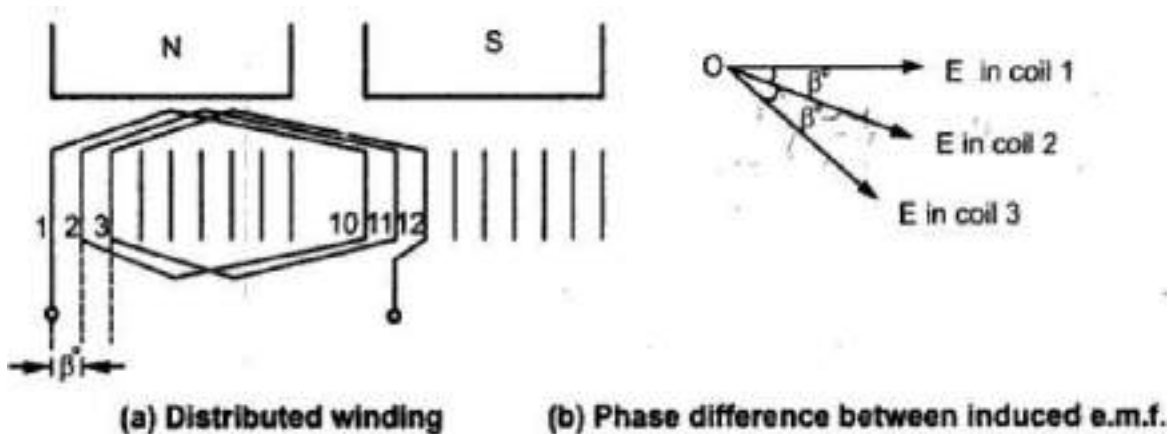

Though the magnitude of e.m.f. in each coil will be same as 'E', as each slot contributes phase difference of β° i.e. 20° in this case, there will exist a phase difference of β° with respect to each other as shown in the figure (b) above. Hence resultant e.m.f. will be phasor sum of all of them as shown in the figure below. So due to distributed winding resultant e.m.f. decreases.

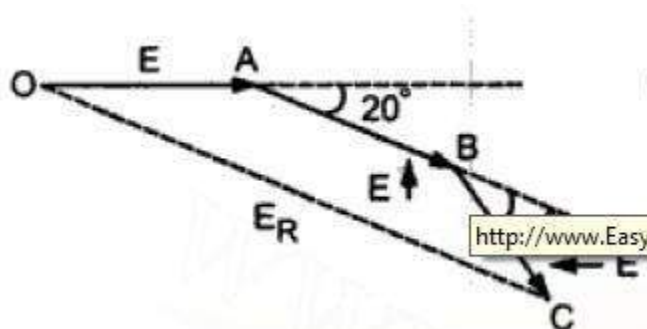

Figure: Phasor sum of e.m.fs in distributed (3 per phase) conductors

The factor by which there is a reduction in the e.m.f. due to distribution of coils is

called '**distribution factor**' denoted as ' K_d '

Derivation of expression for 'distribution factor' K_d :

Let there be ' n ' slots per pole and ' m ' slots per pole per phase. So, there will be ' m ' coils distributed under a pole per phase, connected in series. Let ' E ' be the induced e.m.f. per coil. Then all the ' m ' e.m.f.s induced in the coils will have successive phase angle difference of $\beta = 180^\circ/n$. While finding out the phasor sum of all of them, phasor diagram will approach a shape of a ' m ' equal sided polygon circumscribed by a semicircle of radius ' R '.

This is shown in the figure below. **AB, BC, CD** etc., represent e.m.f. per coil. All the ends are joined at ' O ' which is centre of the circumscribing semicircle of radius ' R '. We know that '**distribution factor**' K_d is defined as:

$$K_d = \frac{E_R \text{ when coils are distributed}}{E_R \text{ when coils are concentrated}}$$

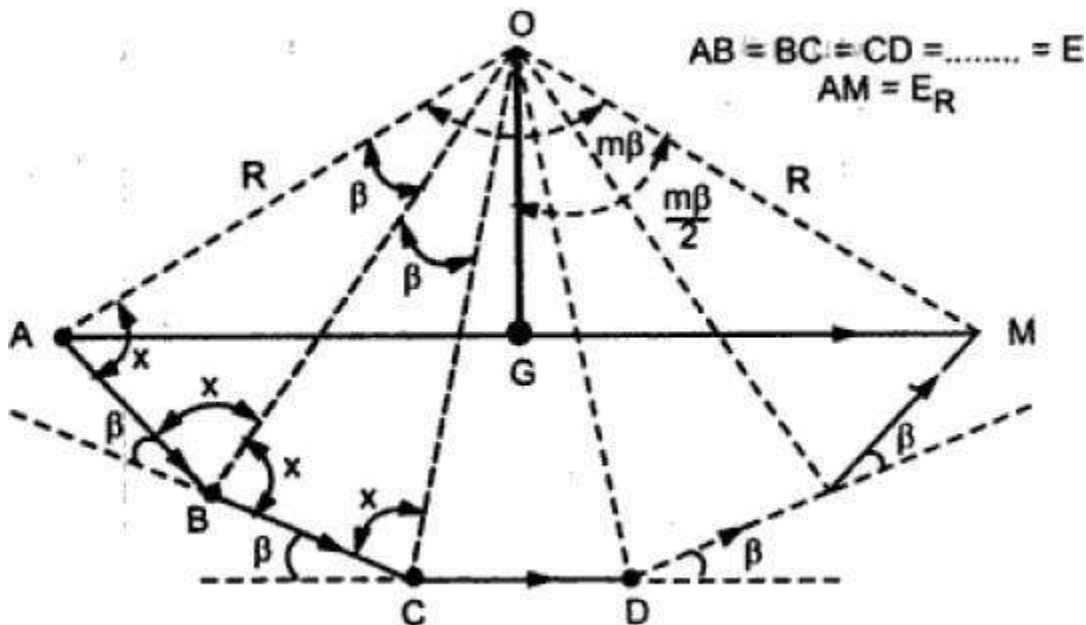

Figure: Phasor sum of ' m ' e.m.f.s in distributed conductors

By a careful study of the above figure and application of the relevant

trigonometric relations we can show that:

The resultant e.m.f. when coils are concentrated is given by:

$$E_R = 2 m R \sin(\beta/2)$$

And the resultant e.m.f. when the coils are distributed is given by:

$$E_R = 2 R \sin (m\beta/2)$$

And thus finally the '**distribution factor**' will be :

$$K_d = \frac{E_R \text{ when coils are distributed}}{E_R \text{ when coils are concentrated}} = \frac{\sin(\frac{m\theta}{2})}{m \sin(\frac{\theta}{2})}$$

.....
Detailed Proof:

Angle subtended by each phasor at the origin 'O' is θ . This can be proved as below. All the triangles OAB, OBC... are similar and isosceles, as $AB = BC = \dots = E$.

Let the base angles be 'X'. In the Above figure $\angle OAB = \angle OBA = \angle OBC = \dots = x$

And $\angle AOB = \angle BOC = \dots = y$ say

In ΔOAB , $2x + y = 180^\circ$

While in the polygon $\angle OBA + \angle OBC + \theta = 180^\circ$

i.e. $2x + \theta = 180^\circ$

Comparing the above two equations $y = \theta$

So $\angle AOB = \angle BOC = \angle COD = \dots = \theta$

If 'M' is the last point of the last phasor, $\angle AOM = m \times \theta = m\theta$ and $AM = E_R =$

Resultant of all the e.m.f.s.

Consider the ΔOAB separately as shown in the figure below.

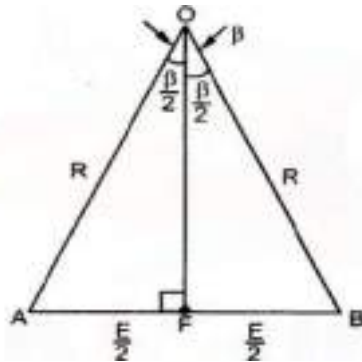

Let OF be the perpendicular drawn on AB bisecting the angle AOB at apex 'O' as $\beta/2$.

$$l(AB) = E \therefore l(AF) = \frac{E}{2} \text{ and let } l(OA) = R.$$

(Here prefix 'l' represents 'length')

$$\therefore \sin\left(\frac{\beta}{2}\right) = \frac{AF}{OA} = \frac{E/2}{R}$$

$$\therefore E = 2R \sin\left(\frac{\beta}{2}\right) \dots\dots\dots(3)$$

Now consider ΔOAM as shown in the above figure -1 and OG is the perpendicular drawn from 'O' on its base bisecting $\angle AOM$ (m Q)

$$\therefore \angle AOG = \angle GOM = \frac{m\beta}{2}$$

$$\therefore l(AM) = E_R$$

$$\therefore l(AG) = \frac{E_R}{2}$$

$$\therefore \sin\left(\frac{m\beta}{2}\right) = \frac{AG}{OA} = \frac{E_R/2}{R}$$

$$\therefore E_R = 2R \sin\left(\frac{m\beta}{2}\right) \dots\dots\dots(4)$$

This is the resultant e.m.f. when coils are distributed.

If all 'm' coils are concentrated all would have been in phase giving E_R as algebraic

sum of all the e.m.f.s.

\therefore

$$E_R = m \times E$$

.... For concentrated

From equation (3), $E = 2 R \sin \left(\frac{\beta}{2} \right)$

$$\therefore E_R = 2 m R \sin \left(\frac{Q}{2} \right)$$

This is resultant e.m.f. when coils are concentrated.

This distribution factor is defined as the ratio of the resultant e.m.f. when coils are distributed to the resultant e.m.f. when coils are concentrated. It is always less than one.

$$\therefore K_d = \frac{E_R \text{ when coils are distributed}}{E_R \text{ when coils are concentrated}} = \frac{2 R \sin \left(\frac{m\beta}{2} \right)}{2 m R \sin \left(\frac{\beta}{2} \right)}$$

$$\therefore K_d = \frac{\sin \left(\frac{m\beta}{2} \right)}{m \sin \left(\frac{\beta}{2} \right)}$$

Where $m = \text{Slots per pole per phase}$

$$B = \text{Slot angle} = \frac{180^\circ}{n}$$

$N = \text{Slots per pole.}$

Generalized Expression for E.M.F. Equation of an Alternator

Considering full pitch and concentrated winding we have earlier obtained the expression for induced emf in a Generator as:

$$E_{ph} = 4.44 f \Phi T_{ph} \text{ volts}$$

But due to short pitch & distributed winding used in practice, this E_{ph} will reduce by factors K_c and K_d . So generalized expression for e.m.f. equation can be written as : $E_{ph} = 4.44 K_c K_d f \Phi T_{ph} \text{ volts}$

For full pitch coil, $K_c = 1$.

For concentrated winding $K_d = 1$.

For short pitch and distributed winding K_c and K_d are always less than unity.

Armature reaction, leakage reactance, synchronous reactance and Synchronous Impedance - Experimental determination:

Armature resistance: Every armature winding has its own resistance which is designated armature resistance per phase $R_a \Omega/\text{Ph}$. It can be measured by a simple *multi meter* which gives DC resistance. But due to skin effect the AC resistance at 50 Hz (Applicable to us) will be higher by approximately 1.6.

Armature leakage resistance: When armature carries a load current it produces its own flux, part of which does not cross the air-gap and links with itself. Such a flux is called leakage flux. This leakage flux makes the armature winding inductive in nature. So effectively the armature winding has an inductive reactance in addition to a resistance. If L is the value of the leakage inductance in Henrys per phase then, the leakage reactance X_L per phase is given by $X_L = \omega L = 2\pi f L \Omega / \text{Ph}$. In Synchronous machines also like in DC machines the value of leakage reactance is much larger than armature resistance R_a .

Armature Reaction:

When a synchronous generator is running on no-load, there will be no current flowing through the armature windings. The flux produced in the air-gap will be due to the field ampere-turns only. When load is connected across the armature terminals, current will flow through the armature windings. These three-phase currents will produce a rotating magnetic field in the air-gap. The effect of the armature flux on the main flux produced by the field ampere-turns is called **Armature Reaction**. The armature flux will distort, oppose or help the field flux causing reduction or increase in the air gap flux depending upon the power factor of the load.

When a synchronous generator is loaded, there will be a change in the terminal voltage due to a voltage drop in armature resistance and armature leakage reactance. *There will be some change in terminal voltage due to armature reaction effect also and it can be viewed as a reactance voltage drop. The corresponding reactance is designated as X_{ar} .*

Synchronous Reactance & Synchronous Impedance: The vector sum of Armature leakage reactance X_L and the apparent reactance due to the effect of Armature

reaction X_{ar} is called *Synchronous Reactance* X_s . Finally the vector sum of R_a and X_s is called *Synchronous Impedance* Z_s .

Armature reaction explained in detail along with phase relationships between all the important parameters in a Synchronous Generator:

The change in terminal voltage due to armature reaction effect can also be viewed as a reactance voltage drop. This can be understood from the following explanation:

The rotor field flux ϕ_f produces an induced emf E in the armature winding. When loaded, this emf causes an armature current, I_a to flow through the winding and the load. The armature ampere-turns produce a flux, ϕ_a in the air gap. This flux ϕ_a produces another emf E_a in the armature windings.

The phase relationship between the field flux ϕ_f , armature induced emf due to field flux E , the armature current I_a the flux produced by armature current ϕ_a , and the emf induced E_a in the armature due to armature flux at different power-factor loads are shown in the figure below. Induced emf E will lag the field flux ϕ_f as shown in the figure.

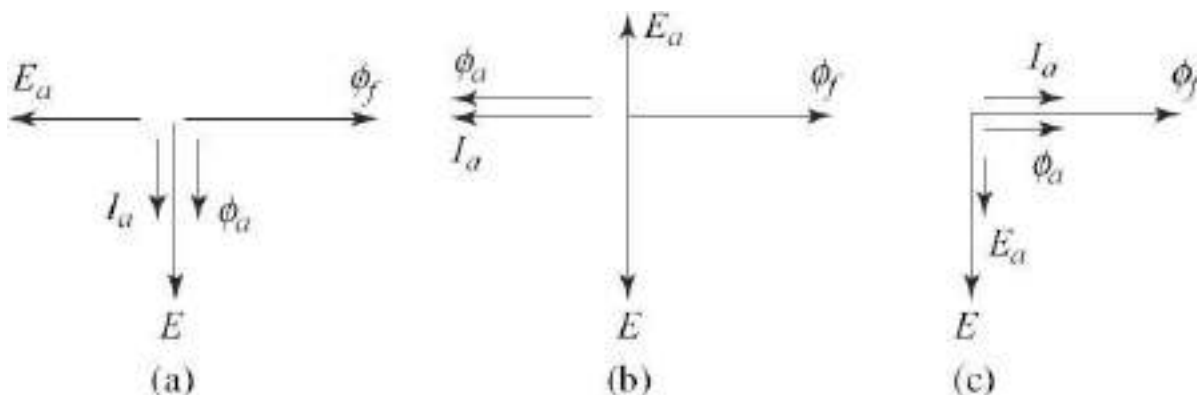

Figure: Phase relationship between the various quantities on (a) Resistive load (unity power factor), (b) Inductive load (zero power factor lagging) (c) Capacitive load (zero power factor leading)

The phase relationship between the induced emf E and the current flowing

through the armature winding I_a will depend upon the power factor of the load. At unity power-factor load I_a will be in phase with E . At zero lagging power-factor load I_a will lag E by 90° whereas at zero leading power-factor load, I_a will lead E by

90°. Flux, ϕ_a produced by armature current I_a will be in time-phase. Emf induced E_a in the armature windings due to ϕ_a will lag ϕ_a by 90°. A component of the generated voltage that would be necessary to overcome this armature reaction voltage must act in the opposite direction.

Since the armature reaction induced voltage always lags the armature current and the flux producing it by 90°, the component of the voltage drop necessary to overcome this generated voltage will always lead the armature current by 90°. This voltage drop is similar to the component of applied voltage needed to overcome leakage reactance drop due to emf of self-induction. Thus the voltage induced due to armature reaction effect can be considered as a reactance drop in the armature winding of the synchronous generator. This fictitious reactance due to armature flux, ϕ_a is called X_{ar} . Reactance due to armature leakage flux, as mentioned earlier, is called leakage reactance X_L . The sum of X_{ar} and X_L is called **synchronous reactance X_s** .

Equivalent circuit and corresponding Phasor diagrams:

We know that in non-salient, i.e., cylindrical rotor type Synchronous generators, the air-gap between the stator and the rotor is uniform. The synchronous reactance, X_s which is the sum of leakage reactance X_L and a fictitious reactance which replaces the effect of armature reaction X_{AR} is the same throughout the entire air-gap between the stator and the rotor. The armature winding resistance R_a is very small as compared to synchronous reactance X_s . The equivalent circuit of a non-salient pole synchronous generator and its phasor diagram with these parameters are shown in the figure (a) below. Figure (b) below shows the approximate equivalent circuit and the corresponding phasor diagram with the armature resistance R_a neglected.

Here V is the terminal voltage and I_a is load current with a phase angle of ϕ . The angle δ between the induced emf E and the terminal voltage V is called the **Power angle** about which we will learn in more detail in the next unit.

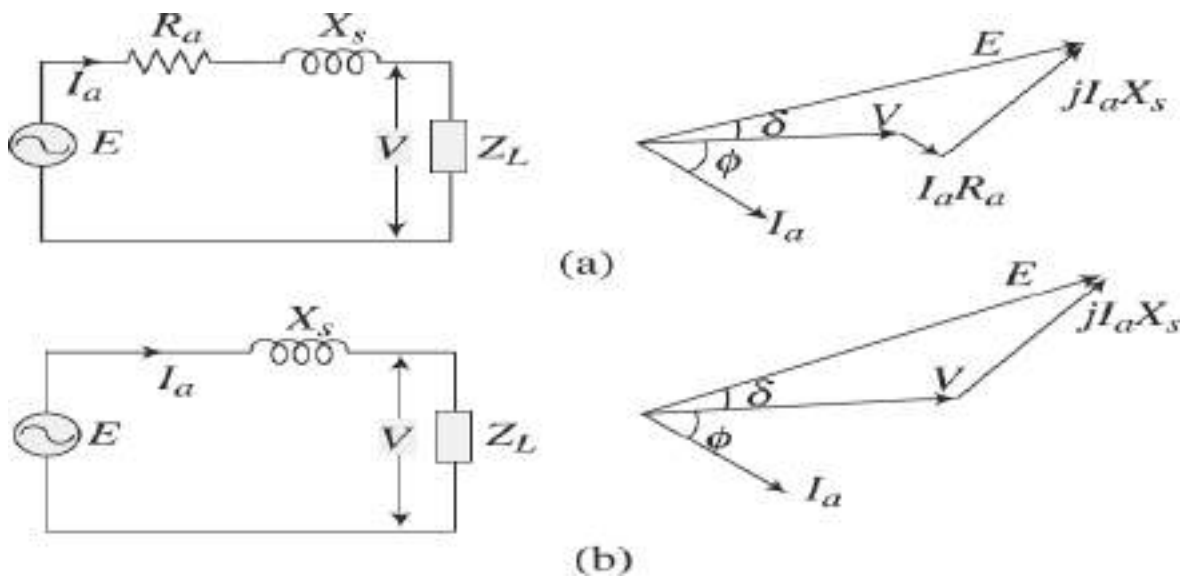

**Figure: (a) Equivalent circuit and phasor diagram of a synchronous generator
(b) Equivalent circuit and phasor diagram with R_a neglected**

The phasor diagrams representing the various quantities of a synchronous generator at different power-factor loads are also shown in the figure below.

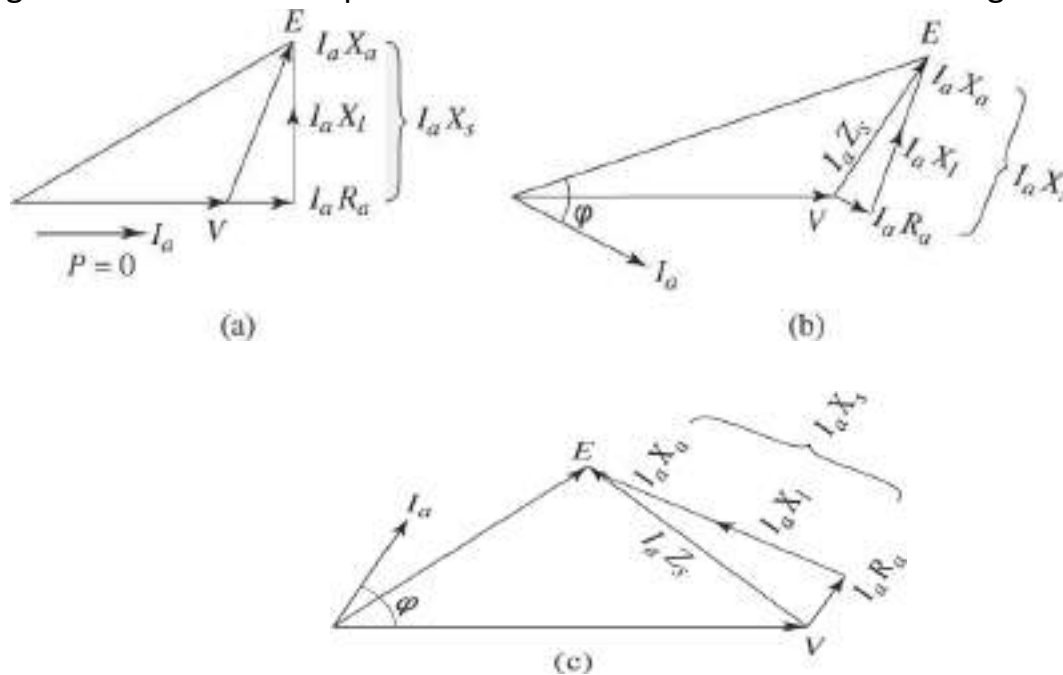

Figure: Phasor diagrams at (a) Unity pf load, (b) Lagging pf load, (c) Leading pf load

Load Characteristics & Voltage regulation of a synchronous generator:

When an alternator is loaded, there will be a voltage drop due to $I_a R_a$ which is in phase with I_a and due to $I_a X_s$, which is leading I_a by 90° . The difference between the terminal voltage V and induced emf E is due to voltage drops in the resistance and reactance, $I_a R_a$ and $I_a X_s$. The relationship between induced emf E and the terminal voltage V is given by:

$$\begin{aligned} E &= V + I_a R_a + I_a (X_L + X_a) \\ \text{or } E &= V + I_a R_a + I_a X_s \\ \text{Or } E &= V + I_a (R_a + X_s) \\ \text{Therefore } E &= V + I_a Z_s \\ \text{Or } V &= E - I_a Z_s \end{aligned}$$

The above expression for V is a function I_a and it's plot is known as the Load Characteristics and shown below for various power factor loads.

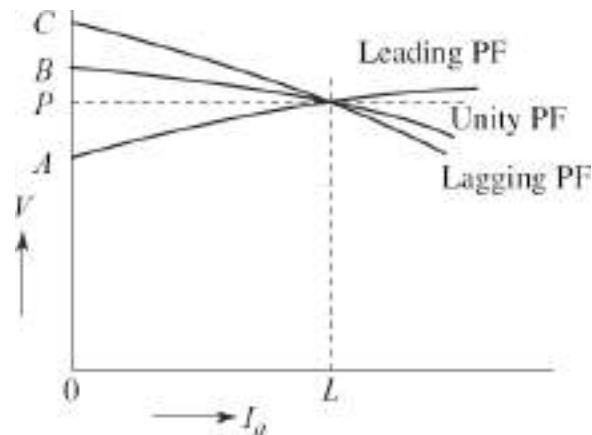

Figure: Effect of armature reaction on terminal voltage of a synchronous Generator at various power factor loads

It has been explained that the terminal voltage of a synchronous generator changes on application of load across its output terminals. The change is due to voltage drop in the windings (in the armature reactance R_a and Leakage reactance

L_a) in addition to the effect of armature reaction. The change in terminal voltage due to armature reaction effect depends upon the magnitude and power factor of the load.

At lagging power-factor load the armature reaction effect is just opposite to that of leading power-factor load. Figure below shows the relationship between terminal voltage and load current of a synchronous generator at different power-factor loads.

Let **OL** be the rated load on the generator. At this load, **OP** is the terminal voltage. If this load of unity power factor is removed, keeping speed and excitation of the alternator constant, the terminal voltage will rise to **OB**, whereas if the load is of lagging power-factor, the terminal voltage will rise to **OC**. For leading power-factor load, terminal voltage however will fall to **OA**. It can be noticed that the change of terminal voltage from full-load to no-load is more in case of lagging or leading power-factor load as compared to unity power-factor load. This is because of the demagnetizing or magnetizing effect of armature reaction on the main field flux.

The variation of terminal voltage from no-load to full-load expressed per unit or percentage of full-load voltage is called regulation of a synchronous generator. The per unit regulation of a Generator is expressed as:

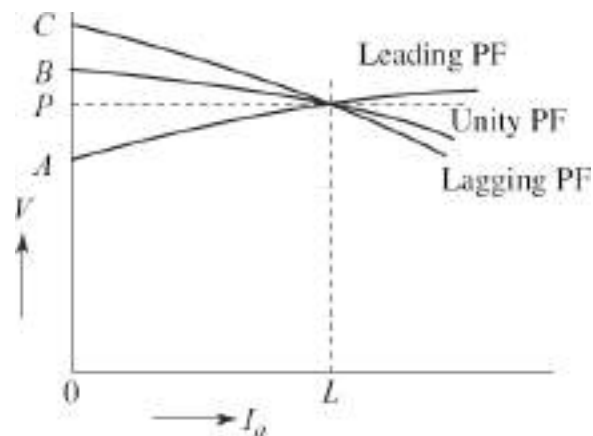

Figure: Variation of terminal voltage of a synchronous generator at different power factor loads

Per unit regulation:

= (Change of terminal voltage from NL to FL)/ FL terminal voltage)

= $(OB - OP) / OP = BP / OP$ *at unity pf load*

$$= (OC - OP) / OP = CP / OP \quad \text{at lagging pf load}$$

$$= (OA - OP) / OP = AP / OP \quad \text{at leading pf load}$$

It can be noticed that at leading power-factor load, the regulation is negative. Since Regulation of an alternator depends on the load and the load power-factor, it is, therefore, necessary to mention power factor also while expressing regulation at a particular load.

An expression for voltage regulation is derived from the phasor diagram of a loaded synchronous generator at a lagging power-factor load shown in the figure below.

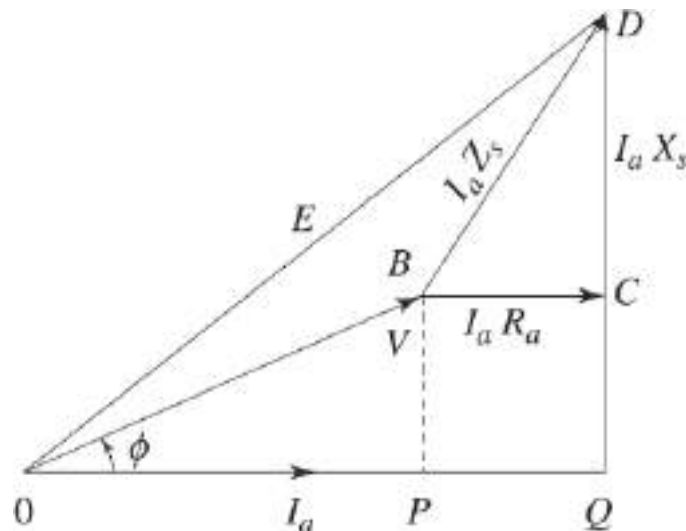

Figure: Phasor diagram of a Synchronous Generator at lagging power factor load

From the triangle **OQD** of figure above we can see that:

$$\begin{aligned} OD^2 &= (OQ)^2 + (QD)^2 \\ &= (OP + PQ)^2 + (QC + CD)^2 \\ \text{Or } E^2 &= (V \cos \phi + I_a R_a)^2 + (V \sin \phi + I_a X_s)^2 \\ \text{Or } E &= \sqrt{(V \cos \phi + I_a R_a)^2 + (V \sin \phi + I_a X_s)^2} \end{aligned}$$

No-load voltage, E corresponding to a particular load current I_a can be calculated if the values of terminal voltage on load, load power-factor angle, armature

resistance R_a and synchronous reactance X_s are known.

For a leading power-factor load, the expression for E can be similarly derived and can be expressed as:

$$E = \sqrt{(V \cos \phi + I_a R_a)^2 + (V \sin \phi - I_a X_s)^2}$$

Thus, in general, the expression for no-load voltage E can be written as,

$$E = \sqrt{(V \cos \phi + I_a R_a)^2 \pm (V \sin \phi + I_a X_s)^2}$$

Where, + sign is for lagging power-factor load and, – sign is for leading power factor load.

Determination of Regulation of a Synchronous Generator:

Commercial generators are manufactured in ratings as high as 500 MVA. To determine voltage regulation directly, such high capacity generators are to be loaded. Loading of such generators to determine their regulation or efficiency in the test laboratory will be a difficult task. Moreover, the prime mover required for driving such a generator may not be available in the test laboratory. It is, therefore, a common practice to test such large machines indirectly by simulating the load conditions.

Such indirect methods will consume only a small amount of power as compared to the power consumed in direct loading method.

We will study the three important methods of determining regulation of an alternator.

Determination of Voltage Regulation by Synchronous Impedance Method:

In this method of determination of regulation, two tests are required to be performed on the machine, namely the open-circuit test and the short-circuit test. Open-circuit test is performed by running the alternator on no-load and at rated speed. The terminal voltage on no-load is measured at different values of excitation current. The relationship between no-load voltage and excitation current gives the open-circuit characteristics (OCC).

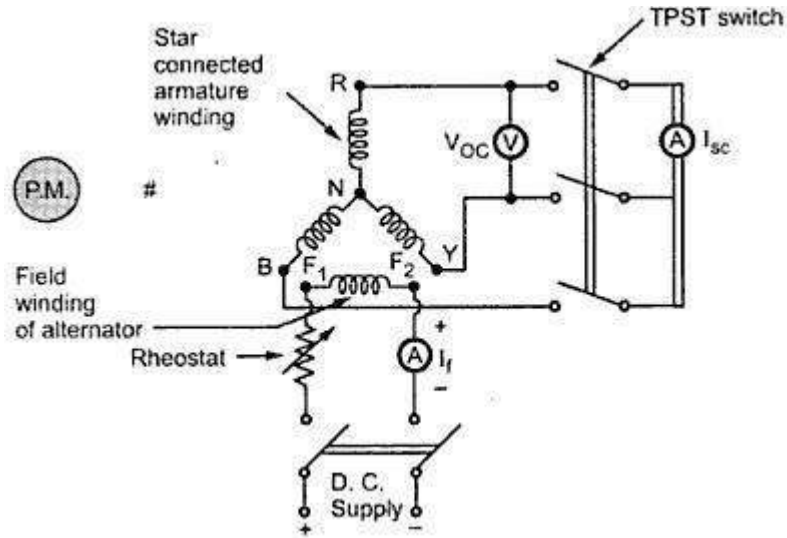

Figure: Open circuit and Short circuit test setup for an Alternator

Short-circuit test is performed by running the alternator at rated speed. Keeping the output terminals short-circuited through an ammeter, reduced excitation current is allowed to flow through the field winding. The relationship between armature current, I_a and the field current I_f gives the short-circuit characteristics (SCC). Test setup for conducting Open circuit and short circuit tests are shown in the figure below.

The OCC and SCC of an alternator are shown in the figure below.

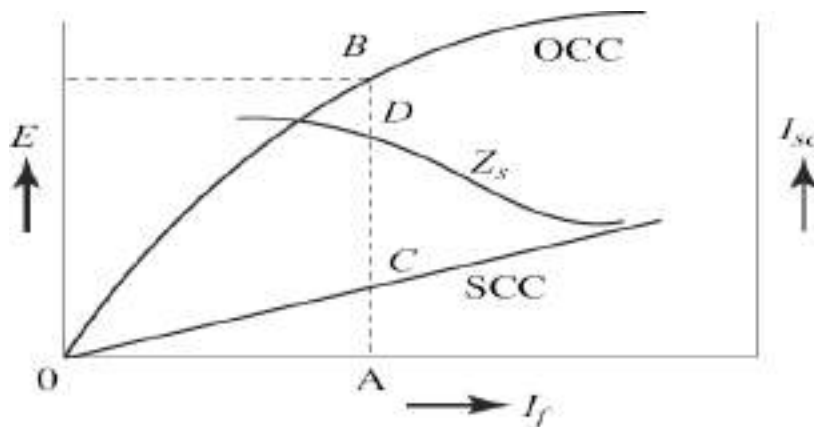

Figure: Open Circuit and Short Circuit Characteristics of a Synchronous Generator

At any particular value of I_f the ratio of open-circuit voltage and short-circuit armature current gives the synchronous impedance Z_s . Referring to the above figure, **Fig. 5.31** at a field current of say **OA**, the induced emf is **AB**. With this excitation, if the armature terminals are short-circuited, a current **AC** will flow through the armature windings. The emf induced, **AB** on open circuit is regarded as being responsible for circulating a short-circuit current of **AC** through the synchronous impedance of the winding. Thus the value of synchronous impedance Z_s at this excitation is given by:

$$Z_s = \text{OC Voltage/SC Current} \quad (\text{at the same excitation})$$

$$= [AB (V) / AC (A) + \Omega]$$

To calculate per-phase value of Z_s , the values of emf and current should be taken as their per-phase values. Because of the non-linear nature of the OCC, the ratio of open-circuit voltage and short-circuit current at various values of excitation currents are different. If the values of Z_s at different excitation are calculated and plotted, we will get a curve for Z_s as shown in the above figure. It is seen that at lower values of excitation current, the value of Z_s is more than its value at higher excitations. We know that:

$$E = \sqrt{(V \cos \phi + I_a R_a)^2 \pm (V \sin \phi + I_a X_s)^2}$$

So to find out E we need to have the values of R_a and X_s . The dc resistance R_a of the stator winding can be directly measured by ammeter-voltmeter method. Then AC resistance is calculated multiplying DC resistance by a factor of 1.5. The synchronous reactance X_s can be calculated from the relation: $X_s = \sqrt{Z_s^2 - R_a^2}$.

After calculating E , **% Regulation** can be calculated as:

$$\% \text{ Regulation} = [(E-V)/V] \times 100$$

We know that under short-circuit test, small amount of field current is necessary to circulate full load current through the winding. The induced emf corresponding to this excitation is small. The value of synchronous impedance calculated from open-circuit and short circuit test data is, therefore, more than its value under actual loading condition.

The regulation calculated using this value of synchronous impedance will, therefore, be more (poorer) than the actual value of regulation. Hence this method gives a very ***pessimistic result***.

Example 1: In a 2000 V. single-phase synchronous generator, a full-load current of 100 A is produced on short-circuit by a field excitation of 2.5 and an emf of 500 V is produced on open-circuit by the same excitation. The armature resistance is 0.8 Ω . Determine the voltage regulation when the generator is delivering a current of 100 A at (a) unity power factor, (b) 0.71 power factor lagging; and (c) 0.8 power factor leading.

Solution

$$\text{Synchronous impedance, } Z_s = \frac{\text{OC Voltage}}{\text{SC Current}} = \frac{500}{100} = 5 \Omega$$

$$X_s = \sqrt{Z_s^2 - R_a^2} = \sqrt{5^2 - 0.8^2} = 4.935 \Omega$$

$$\text{Induced emf } E = \sqrt{(V \cos \phi + I_a R_a)^2 + (V \sin \phi + I_a X_s)^2}$$

(a) At unity pf

$$E = \sqrt{(V \cos \phi + I_a R_a)^2 + (V \sin \phi + I_a X_s)^2}$$

$$= \sqrt{(2000 \times 1 + 100 \times 0.8)^2 + (2000 \times 0 + 100 \times 4.935)^2}$$

$$= \sqrt{(2080)^2 + (4.935)^2} = 2138 \text{ V}$$

$$\text{Regulation} = \frac{E - V}{V} \times 100 = \frac{(2138 - 2000)}{2000} \times 100 = 6.9\%$$

(b) At 0.71 pf lagging, ($\cos \phi = 0.71$, $\sin \phi = 0.704$)

$$E = \sqrt{(2000 \times 0.71 + 100 \times 0.8)^2 + (2000 \times 0.704 + 100 \times 4.935)^2}$$

$$= \sqrt{(1420 + 80)^2 + (1408 + 493.5)^2} = 2422 \text{ V}$$

$$\text{Regulation} = \frac{E - V}{V} \times 100$$

$$= \frac{2422 - 2000}{2000} \times 100 = 21.1\%$$

(c) At 0.8 pf leading, ($\cos \phi = 0.8$, $\sin \phi = 0.6$)

$$E = \sqrt{(2000 \times 0.8 + 100 \times 0.8)^2 + (2000 \times 0.6 - 100 \times 4.935)^2}$$
$$= \sqrt{(1680)^2 + (706.5)^2} = 1822.5 \text{ V}$$

$$\text{Regulation} = \frac{E - V}{V} \times 100$$
$$= \frac{(1822.5 - 2000)}{2000} \times 100 = -8.87\%$$

Note that the regulation is negative at this leading power factor load.

Voltage Regulation by MMF Method:

This method of determining the regulation of an alternator is also called Ampere-turn method or **Rothert's M.M.F. method**. This method is also based on the results of open circuit test and short circuit test on an alternator like Synchronous impedance method.

In mmf (magneto motive force) method, the mmf required to produce an emf of $E' = V + I_a R_a$ is obtained by adding vectorially $I_a R_a$ drop to the terminal voltage V . The mmf in terms of field current to get this voltage is found out from the OCC. From the short circuit characteristic, the field current necessary to send rated armature current is determined. The mmf representing this field current is assumed to be necessary to send rated current through the armature leakage reactance and at the same time overcome armature reaction.

These mmfs or ampere-turns are produced by field currents say I_{f1} and I_{f2} respectively. I_{f1} is found out from OCC and I_{f2} is found out from SCC as shown in the figure (a) below.

I_{f1} produces E' which lags behind I_{f1} by 90° . I_{f2} produces an emf which will be able to circulate the rated current through the armature on short circuit. This emf is equal to the voltage drop in the armature due to synchronous reactance and hence is drawn in phase opposition to I_a .

The phasor sum of I_{f1} and I_{f2} gives the total field current I_f required to induce an

emf **E**. The value of **E** corresponding to I_f is found from the OCC and voltage regulation is calculated as: **%Voltage regulation = $[(E - V)/V] \times 100$**

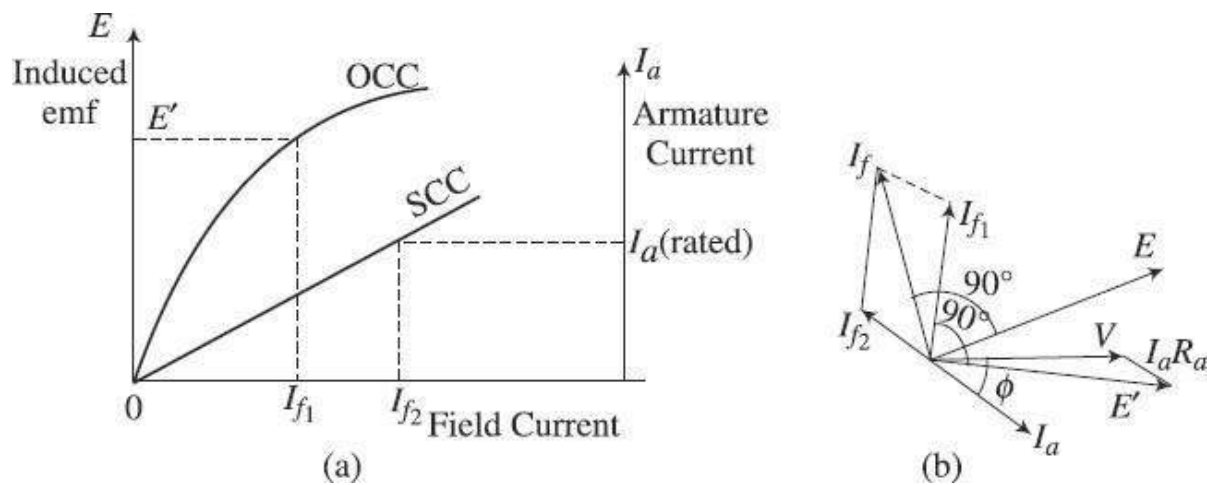

Figure: (a) OCC and SCC of a Synchronous Generator (b) Phasor diagram for determining resultant field current.

Step by step procedure for calculation of voltage regulation by mmf method is given below.

1. Open-circuit & Short Circuit tests are conducted and OCC & SCC are drawn just like in EMF method.
2. Armature resistance is measured by ammeter-voltmeter method by applying a low voltage DC. Then AC resistance R_A is calculated as 1.5 times the DC resistance.
3. The procedure basically involves reading the data from the OCC & SCC and then drawing the Phasor diagram step by step alternately.
4. Armature rated voltage V is drawn to scale as reference phasor in the phasor diagram. Let us assume that regulation is required to be calculated at an armature current of I_a and power factor angle of ϕ . Then phasor I_a is drawn making a lag angle of ϕ with the V -axis. Then $I_a R_a$ drop is added vectorially (in phase with I_a) to V to get the no load induced voltage E' . For this voltage E' to be induced the required field current I_{f1} is read from the **OCC**. This value of I_{f1} is drawn to scale such that the induced emf E' lags I_{f1} by 90° (see phasor diagram in figure **b** above).
5. The field current I_{f2} required to circulate the rated current through the armature on short-circuit is read from the **SCC**. This is the field current required to induce an emf which will balance the synchronous reactance voltage drop, $I_a X_s$. Then I_{f2} is drawn to scale in phase opposition to I_a . Then finally the resultant of I_{f1} and I_{f2} is drawn to give I_f as shown in the phasor diagram.

6. From the phasor diagram using the field current scale factor, I_f is obtained in amperes. From the OCC the value of induced emf E corresponding to this net field

current of I_f is read. Using this value of emf E and the rated terminal voltage V , voltage regulation is calculated using the formula

$$\% \text{Voltage regulation} = [(E - V) / V] \times 100$$

The value of regulation found out by mmf method is lower than the actual regulation of the alternator and hence is an ***Optimistic method***.

Zero Power Factor (ZPF) Method:

This method is also called **Potier** method. In the operation of any alternator, the armature resistance drop $I_a R_a$, and armature leakage reactance drop $I_a X_L$ are actually e.m.f. quantities while the armature reaction is basically a m.m.f. quantity. In the synchronous impedance method all the quantities are treated as e.m.f. quantities where as in M.M.F method all are treated as m.m.f. quantities. Hence in both the methods, we are away from the true value.

*This method is based on the separation of armature leakage reactance and armature reaction effects into emf and mmf quantities respectively. The armature leakage reactance X_L , is called **Potier reactance** in this method, hence this method is also called **Potier reactance method**.*

To determine armature leakage reactance and armature reaction m.m.f. separately, the following two tests are to be performed on the given alternator.

1. Open circuit test
2. Zero power factor test

The single experimental setup to perform both these tests is shown in the figure below.

The open circuit characteristic giving the relationship between induced emf E and the field current I_f on no-load at rated speed is obtained from the open circuit test exactly in the same steps as in EMF and MMF tests *and is given below for quick reference.*

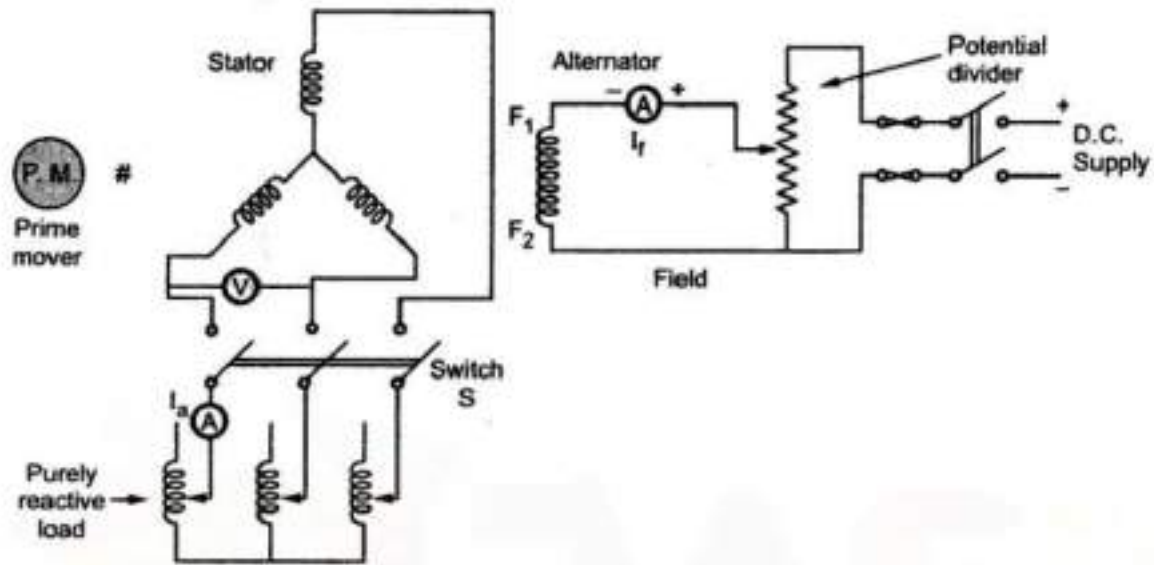

Figure: Experimental setup for ZPF method

The switch S is kept open.

1. *The alternator is driven by its prime mover at its synchronous speed and maintained constant throughout the test*
2. *The excitation is varied in definite number of steps with the help of the potential divider, from zero until rated terminal voltage is exceeded. The open circuit e.m.f. is measured with the help of voltmeter. The readings are tabulated.*
3. *From this data the OCC of the alternator i.e plot of induced EMF E versus I_f is plotted*

Zero Power Factor Test

ZPF test gives data to get a graph of terminal voltage against excitation when delivering full load zero power factor current.

By closing the switch S a purely inductive load (with a power factor of $\cos 90^\circ$ i.e., zero PF lagging) gets connected to the alternator through an ammeter. The

machine speed is maintained constant at its synchronous value. The load current delivered by the alternator to such a purely inductive load is maintained constant

at its rated full load value by varying excitation and by adjusting variable inductance of the inductive load.

In this test, there is no need to obtain number of points to obtain the ZPF curve. Only two points are enough to construct the zero power factor saturation curve as explained below.

One point for this curve is zero terminal voltage (short circuit condition) and the field current required delivering full load short circuit armature current. This point is obtained from the SCC (Short Circuit Characteristic which is also required to be plotted along with OCC). The other point is the field current required to obtain rated terminal voltage while delivering the rated full load armature current to the Inductive load. With the help of these two points the ZPF saturation curve can be obtained and plotted along with OCC and SCC as shown in the figure below.

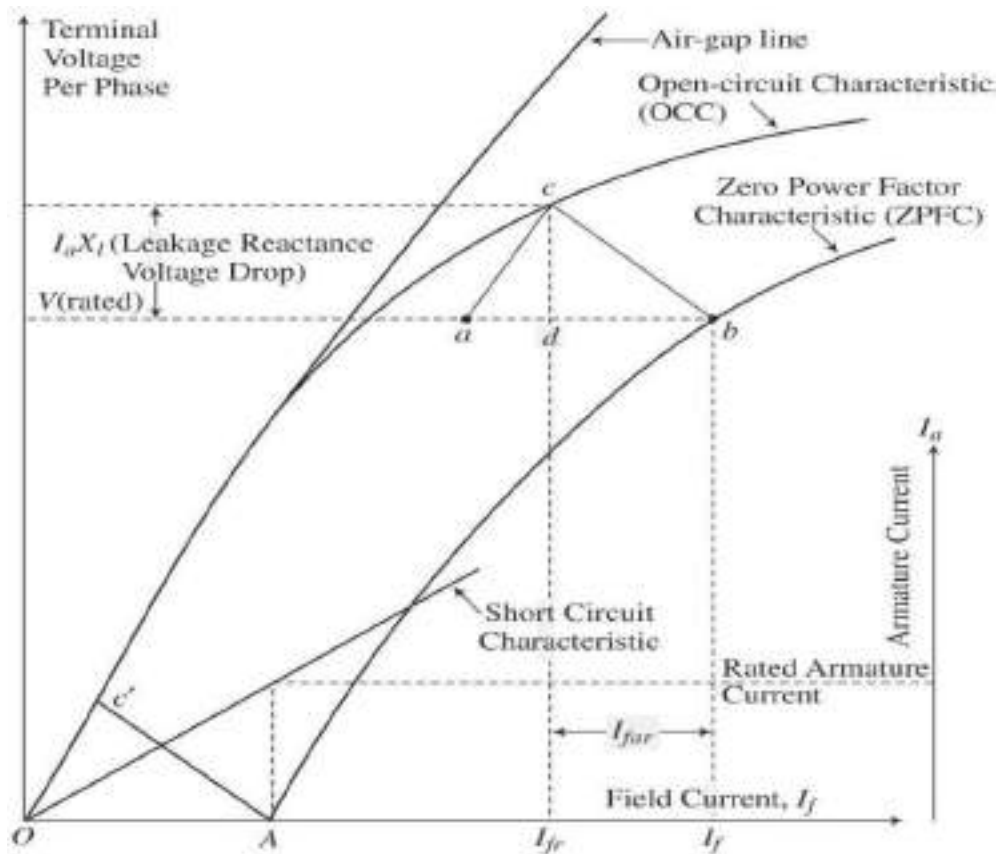

Figure: Open circuit and Zero Power Factor load characteristics

Figure above shows the **OCC**, **SCC** and **ZPF** characteristics. Important properties and the data that can be obtained from the above characteristics are given below.

1. Distance **OA** represents the field current required for flow of rated armature current when the terminal voltage is zero (obtained from Short circuit test)
2. Point **b** on **ZPFC** corresponds to the terminal voltage at a field current of I_f when the alternator is supplying rated current at zero power factor inductive load.
3. The distance **ab** is equal to distance **OA** (and both are parallel). Line **ac** is drawn from point **a** parallel to the air gap line to touch the **OCC** at point **c**. Then point **c** and **b** are joined. Triangle **abc** is called the Potier triangle.
4. Drop a perpendicular from point **c** to **ab** meeting at point **d**. The vertical distance **cd** of the Potier triangle represents the leakage reactance drop $I_a X_L$. Distance **db** represents the field current required to oppose the armature reaction mmf. Distance **ad** represents the field current required to overcome leakage reactance voltage drop $I_a X_s$.
5. From the Potier triangle, therefore leakage reactance of the armature is calculated as: $X_L = \frac{\text{Voltage drop per phase (distance } cd)}{\text{Rated armature current per phase}}$

*It is not necessary to draw the complete ZPFC by taking several readings. If we slide the Potier triangle **abc** downwards such that the point **c** always rests on the OCC, then the locus of point **b** becomes the ZPF Characteristic.*

A step by step procedure for drawing the OCC, SCC & ZPF characteristics while simultaneously drawing the phasor diagram and then calculation of voltage regulation using Potier triangle method (ZPF Method) is given below.

1. Draw the open circuit characteristic by choosing a suitable scale for rated terminal voltage **V** and the field current I_f . The voltage should be the per phase value.
 2. Choosing an appropriate scale factor for armature current I_a draw the **SCC** also on the same plot such that both plots can be seen as in the figure above.
 3. **OA** is marked on I_f axis representing the field current required on short circuit to drive the rated armature current.
-

-
4. Another point **b** is located by taking the length of field current I_f and length of rated terminal voltage required to drive the rated armature current into full-load zero power factor lagging load (found from **ZPF** test).

5. Mark **ab** equal and parallel to **OA**. From point **a** draw a line parallel to the air-gap line touching the **OCC** at point **c**.
6. Join **c** and **b**. Triangle **abc** is the **Potier** triangle. Drop a perpendicular from **c** to **d** onto the line **ab**. Measure the distance **cd** and calculate the leakage reactance X_L by considering the voltage scale. Determine the value of R_a .
7. Calculate $E' = V + I_a R_a + j I_a X_L$ (By phasor addition as shown in the Phasor diagram below)
8. Corresponding to voltage E' find the field current from the **OCC**, (which is I_{fr} in the figure containing **ZPF** characteristics. Next draw the phasor I_{fr} leading E' by 90° . Next draw I_a lagging voltage V by the power factor angle ϕ . Then draw I_{far} in phase opposition to I_a . Draw the resultant field current I_f , by adding I_{fr} and I_{far} vectorially.
9. From **OCC** find the value of E corresponding to I_f
10. Calculate percentage voltage regulation as:

$$\% \text{ Voltage regulation} = [(E-V)/V] \times 100$$

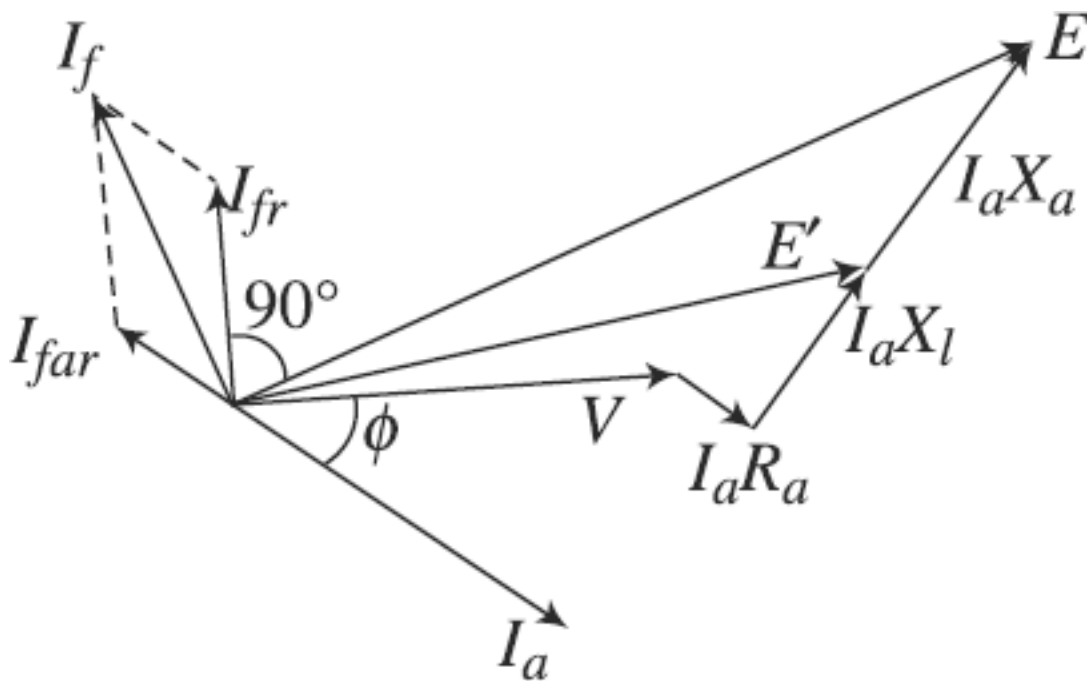

Figure 5-37: Phasor diagram of a Synchronous Generator – Determining Voltage Regulation

Illustrative Examples:

Example 1: An armature of a three phase alternator has 120 slots. The alternator has 8 poles. Calculate its distribution factor.

Solution: $n = \frac{\text{slots}}{\text{Pole}} = \frac{120}{8} = 15$

$$m = \text{Slots/Pole/Phase} = \frac{15}{3} = 5$$

$$\beta = \frac{180^\circ}{n} = \frac{180^\circ}{15} = 12^\circ$$

$$\therefore K_d = \frac{\sin\left(\frac{m\beta}{2}\right)}{m \sin\left(\frac{\beta}{2}\right)} = \frac{\sin\left(\frac{5 \times 12^\circ}{2}\right)}{5 \times \sin\left(\frac{12^\circ}{2}\right)} = 0.957$$

Example 2: In a 4 pole, 3 phase alternator, armature has 36 slots. It is using an armature winding which is short pitched by one slot. Calculate its coil span factor.

Solution: $n = \frac{\text{Slots}}{\text{Pole}} = \frac{36}{4} = 9$

$$\beta = \frac{180^\circ}{n} = 20^\circ$$

Now coil is shorted by 1 slot i.e. by 20° to full pitch distance.

$$\therefore \alpha = \text{Angle of short pitch} = 20^\circ$$

$$\therefore K_c = \cos\left(\frac{\alpha}{2}\right) = \cos\left(\frac{20^\circ}{2}\right) = 0.9848$$

Example 3: An Armature runs at 250 r.p.m. and generates an e.m.f. at 50 Hz. There are 216 slots each containing 5 conductors. The winding is distributed and full pitch. All the conductors of each phase are in series and flux per pole is 30 mWb which is sinusoidal distributed. If the winding is star connected, determine the value of induced e.m.f. available across the terminals.

Solution: $N_s = 250 \text{ r.p.m.}, f = 50 \text{ Hz}$
 $N_s = \frac{120f}{P}$ i.e. $250 = \frac{120 \times 50}{P}$

$$\therefore \text{Number of poles } P = 24$$

$$\begin{aligned} \therefore \mathbf{n} &= \frac{\text{Slots}}{\text{pole}} = \frac{216}{24} = 9 \\ \therefore \mathbf{m} &= \frac{\quad}{3} = 3 \end{aligned}$$

$$\therefore \beta = \frac{180^\circ}{n} = \frac{180^\circ}{9} = 20^\circ$$

We know that the distribution factor K_d is given by:

$$K_d = \frac{\sin\left(\frac{m\beta}{2}\right)}{m \sin\left(\frac{\beta}{2}\right)} = \frac{\sin\left(\frac{3 \times 20}{2}\right)}{3 \times \sin\left(\frac{20}{2}\right)} = 0.9597$$

$K_c = 1$ as winding is full pitch.

Total number of conductors $Z = 216 \times 5 = 1080$

$$\therefore Z_{ph} = \frac{Z}{3} = \frac{1080}{3} = 360$$

$$T_{ph} = \frac{Z_{ph}}{2} = \frac{360}{2} = 180 \dots \dots \dots (2 \text{ conductors} \rightarrow \text{turn})$$

We know that $E_{ph} = 4.44 K_c K_d f \Phi T_{ph}$

$$= 4.44 \times 1 \times 0.9597 \times 50 \times 30 \times 10^{-3} \times 180$$

$$= 1150.48 \text{ V}$$

$$E_{line} = \sqrt{3} E_{ph}$$

$$= \sqrt{3} \times 1150.48 = 1992.70 \text{ V.}$$

Example 4: A 3 phase, 16 Pole, star connected alternator has 144 slots on the armature periphery. Each slot contains 10 conductors. It is driven at 375 r.p.m. The line value of e.m.f. available across the terminals is observed to be 2.657 KV. Find the frequency of the induced e.m.f and flux per pole.

Solution: Number of Poles $P = 16$, $N_s = 375$ r.p.m.,

Slots = 144, Conductor/Slots = 10, $E_{line} = 2.657$ Kv

$$N_s = \frac{120f}{P} \quad \text{i.e.} \quad 375 = \frac{120 \times f}{16}$$

$$\therefore f = 50 \text{ Hz}$$

Assuming full pitch winding, $K_c = 1$

$$\therefore \text{Slots} \quad n = \frac{\text{Pole}}{n} = \frac{144}{16} = 9$$

$$\therefore m = \frac{3}{3} = 3$$

$$\therefore \beta = \frac{180^\circ}{n} = \frac{180^\circ}{9} = 20^\circ$$

We know that the distribution factor K_d is given by: $K_d = \frac{\sin\left(\frac{m\beta}{2}\right)}{m \sin\left(\frac{\beta}{2}\right)} = \frac{\sin\left(\frac{3 \times 20}{2}\right)}{3 \times \sin\left(\frac{20}{2}\right)} = 0.9597$

Total conductors = Slots \times Conductors / Slot

i.e. $Z = 144 \times 10 = 1440$

$$\therefore Z_{ph} = \frac{Z}{3} = \frac{1440}{3} = 480$$

$$T = \frac{Z}{ph} = \frac{480}{3} = 240$$

$$E_{ph} = \frac{E_{line}}{\sqrt{3}} = \frac{22.657}{\sqrt{3}} = 1.534 \text{ kV}$$

Using the above values in the equation for EMF we get : $E_{ph} = 4.44 K_c K_d f \Phi T_{ph}$

$$1.534 \times 10^3 = 4.44 \times 1 \times 0.9597 \times 50 \times \Phi \times 240$$

From which we get: $\Phi = (1.534 \times 10^3) / (4.44 \times 1 \times 0.9597 \times 50 \times 240)$

$$\Phi = 0.03 \text{ Wb} = 30 \text{ mWb}$$

Important questions:

1. Compare and contrast the technical features of Synchronous Generators with (i) Induction Generators and (ii) DC Generators.
 2. (a) Explain the basic principle of operation and construction details of 3 ϕ Synchronous Generators.
(b) What are the advantages of Stationary Armature and Rotating Field system as compared to Stationary field and Rotating Armature System in a Synchronous Generator?
 3. With the help of neat sketches explain the two types of Rotor Construction, their advantages vs. disadvantages and applications.
 4. (a) Explain with the help of a neat sketch how a Brushless exciter system works.
(b) What is a pilot exciter and how it works along with a brush less exciter.
 5. With the help of simple sketches explain the following terms pertaining to Armature windings in a Synchronous Generator :
(a) Pole pitch & Slot angle (β): (b) Single Layer and Double Layer Winding
(c) Full Pitch and Short Pitch Winding (d) Concentrated and Distributed Winding
(e) Integral & Fractional Slot Winding.
 6. Derive an expression for the EMF generated in a Synchronous generator assuming full pitch and concentrated winding.
 7. Define the terms (a) Pitch or Coil Span factor & (b) Distribution factor in Synchronous Generators and derive their expressions with relevant figures.
-

Then give the generalized EMF equation including the effects of short pitch and distributed winding.

-
8. Explain in detail the terms Armature reaction, leakage reactance, synchronous reactance and Synchronous Impedance in a Synchronous Generator.
 9. Draw the equivalent circuit of a Synchronous Generator and also the phasor diagrams with (i) Lagging Pf Load (ii) Unity Pf Load (iii) Leading Pf Load
 10. Explain what are Load Characteristics & Voltage regulation of a Synchronous Generator.
 11. Explain in detail the determination of Voltage regulation by the following three important Methods:
 - (i) Synchronous Impedance or EMF method
 - (ii) MMF method
 - (iii) Zero Power Factor Method
 12. All the above worked out illustrative problems.

UNIT-IV

PARALLEL OPERATION OF SYNCHRONOUS MACHINES

- Synchronizing Alternators with Infinite Bus bars
- Synchronizing Power / Torque
- Parallel operation and Load sharing
- Effect of change of Excitation and Mechanical power input.

SYNCHRONOUS MOTORS

- Theory of operation- phasor diagrams
 - Variation of current and power factor with excitation
 - Synchronous condenser
 - Hunting and its suppression
 - Methods of starting
- Important Questions

Introduction:

For a clear understanding of the parallel operation of Generators the concept of Power Angle & Torque Angle and operation of Synchronous Generators alone is to be understood first. Hence these topics are covered first before dealing with Parallel operation of Synchronous Generators.

Power Angle and Torque Angle in Synchronous Generators:

A synchronous generator is a synchronous machine used as a generator. It converts mechanical power to three-phase electrical power. The source of mechanical power, the *prime mover*, may be a diesel engine, a steam turbine, a water turbine, or any similar device. **Whatever the source, it must have the basic property that its speed is almost constant regardless of the power demand. If that were not so, then the resulting power system's frequency would vary..**

All the mechanical power going into a synchronous generator does not become electrical power out of the machine. The difference between input power and output power represents the losses of the machine. The power-flow diagram of a synchronous generator is shown in the figure below.

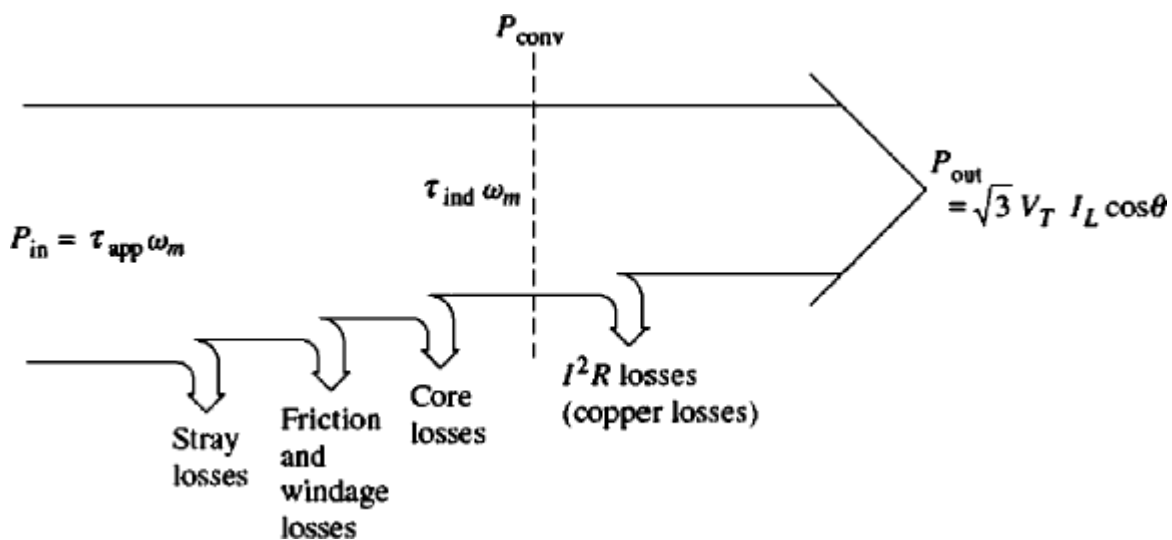

Figure: The power-flow diagram of a Synchronous Generator.

The input mechanical power which is the shaft power in the generator given by:

$$P_{in} = \tau_{app} \cdot \omega_m$$

while the power converted from mechanical to electrical form internally is given by:

$$P_{con} = \tau_{ind} \cdot \omega_m = 3E_a I_a \cos \gamma$$

where ' γ ' is the phase angle between E_a and I_a . The difference between the input power to the generator and the power converted in the generator represents the mechanical, core, and stray losses of the machine.

The *Real (P_{out}) and Reactive (Q) electrical output power* of the synchronous generator can be expressed in phase quantities as:

$$P_{out} = 3V_{\phi} I_a \cos \Theta \quad \dots (1)$$

$$Q_{out} = 3V_{\phi} I_a \sin \Theta \quad \dots (2)$$

where Θ is the phase angle between the phase voltage V_{ϕ} and the armature current I_a .

If the armature resistance R_a is ignored (since $X_s \gg R_a$), then a very useful relation can be derived to approximate the output power of the generator. To derive this relation, refer the phasor diagram shown in the figure below which shows a simplified phasor diagram of a generator with the stator resistance ignored.

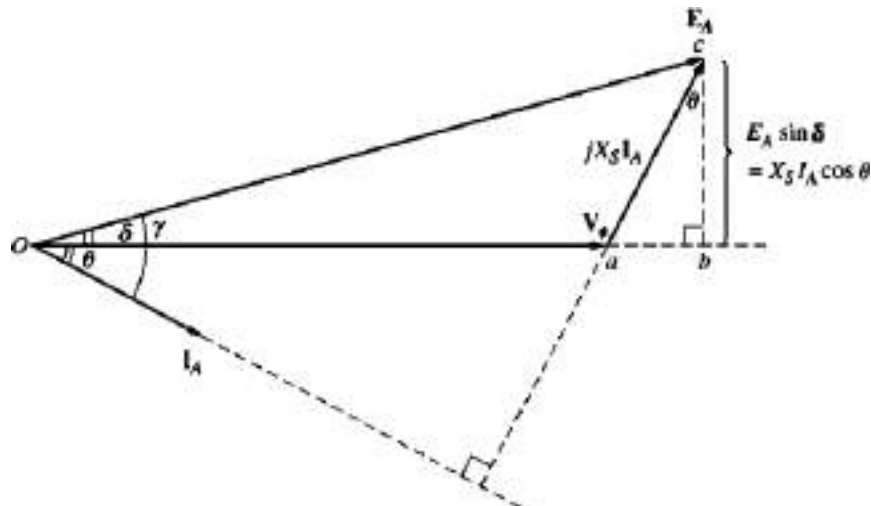

Figure: Simplified Phasor diagram with armature resistance ignored.

Notice that the vertical segment bc can be expressed as $E_A \sin \delta$ or $X_s I_a \cos \Theta$. Therefore:

$$I_a \cos \Theta = E_A \sin \delta / X_s$$

And substituting this in the above equation for power output $P_{out} = 3V_{\phi} I_a \cos \Theta$ we get:

$$P = (3V_{\phi} E_A \sin \delta) / X_s \quad \dots (3)$$

Since we have assumed the resistances to be negligible there are no electrical losses in the generator and the above equation for P stands good for both P_{con} and P_{out} .

The above equation (3) shows that the power produced by a synchronous generator depends on the angle δ between V_ϕ and E_A . The angle δ is known as the **Power angle** of the machine. The variation of Power and Torque as a function of δ is shown in the figure below. Notice also that the maximum power that the generator can supply occurs when $\delta = 90^\circ$. At $\delta = 90^\circ$, $\sin \delta = 1$, and

$$P_{max} = (3V_\phi E_A) / X_S$$

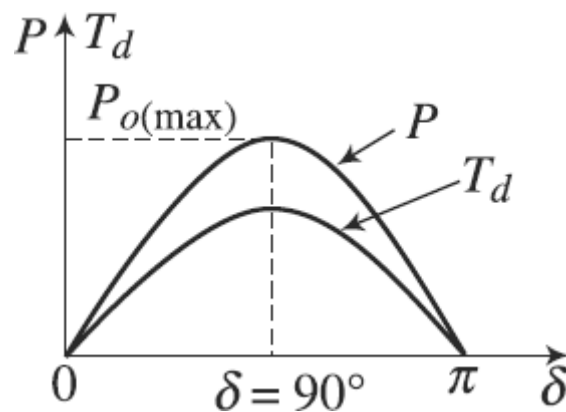

Figure: Power/torque-angle characteristic of a cylindrical rotor type Synchronous Generator

The maximum power indicated by this equation is called the **static stability limit** of the generator. Normally, real generators never even come close to this limit. Full-load torque angles of 15 to 20° are more typical of real machines.

Now take another look at Equations (1), (2) and (3) we find that if V_ϕ is assumed to be constant, then the **real power output is directly proportional to $I_a \cos \Theta$** and the **reactive power output is directly proportional to $I_a \sin \Theta$** . These facts are useful in plotting phasor diagrams of synchronous generators as loads change.

An alternative expression for the induced torque in a synchronous generator can be derived from the above equation for power converted (3).

Because $P_{conv} = \tau_{ind} \cdot \omega_m$ the induced torque can be expressed as:

$$\tau_{ind} = (3V_\phi E_A \sin \delta) / (\omega_m X_S) \quad -- \quad (4)$$

This expression describes the *induced torque* in terms of electrical quantities where as the equation: $\tau_{ind} = k \cdot B_R \cdot B_{net} \sin \delta$ gives the same information in terms of magnetic flux densities. In this context we should know that the same δ which is now the phase angle between the Rotor flux density B_R and the net flux density B_{net} in the stator is called *Torque angle*. As can be seen in the same above figure Torque also becomes maximum when $\delta = 90^\circ$

The synchronous generator operating alone:

The power input to an alternator is applied by a prime mover, which in most cases is a steam turbine. This input is directly proportional to the electrical output. If output is increased, more power must be developed by the prime mover, otherwise, speed will drop. If speed drops, there will be a drop in output voltage and frequency. On the other hand, if by increasing the prime mover steam supply, input power is increased without increasing the electrical output, the speed of the set will increase. Increase in speed will cause increase in terminal voltage and frequency.

It is rare to find a synchronous generator supplying its own load independently. For emergency power supply requirement, small synchronous generators driven by diesel engines are used.

The performance of a synchronous generator under load varies greatly depending on the power factor of the load and on whether the generator is operating alone or in parallel with other synchronous generators. In this section, we will study the behavior of synchronous generators operating alone. Here the concepts are illustrated with simplified phasor diagrams ignoring the effect of R_A . Unless otherwise stated, the speed of the generators is assumed to be constant, and all terminal characteristics are drawn assuming constant speed. Also, the rotor flux in the generators is assumed constant unless their field current is explicitly changed.

The Effect of Load Changes on a Synchronous Generator Operating Alone:

To understand the operating characteristics of a synchronous generator operating alone, examine a generator supplying a load. A diagram of a single generator supplying a load is shown in the figure below.

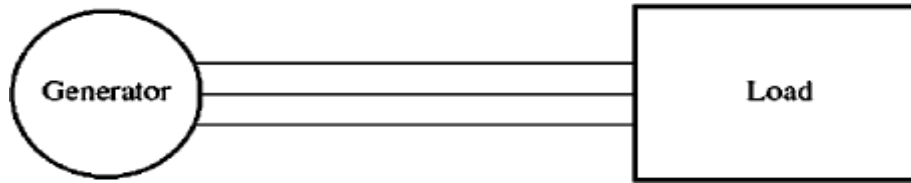

Figure: A Single Generator supplying a load.

An increase in the load is an increase in the real and/or reactive power drawn from the generator. Such a load increase increases the load current drawn from the generator. Because the field resistor has not been changed, the field current is constant, and therefore the flux ϕ is constant. Since the prime mover also keeps a constant speed ω , the *magnitude of the internal generated voltage* $E_a = K \phi \omega$ is constant.

If E_a is constant, then, what does vary with a changing load? The way to find out is to construct phasor diagrams showing an increase in the load, keeping the constraints on the generator in mind.

First, let us examine a generator operating at a lagging power factor. If more load is added at the *same power factor*, then $|I_a|$ increases but remains at the same angle θ with respect to V_ϕ as before. Therefore, the armature reaction voltage $jX_s I_a$ is larger than before but at the same angle. Now since

$$E_a = V_\phi + jX_s I_a$$

$jX_s I_a$ must stretch between V_ϕ at an angle of 0° and E_a , which is constrained to be of the same magnitude as before the load increase. If these constraints are plotted on a phasor diagram, there is one and only one point at which the armature reaction voltage can be parallel to its original position while increasing in size. The resulting plot is shown in the figure a below.

If the constraints are observed, then it is seen that as the load increases, the voltage V_ϕ decreases rather sharply.

Now suppose the generator is loaded with unity-power-factor loads. With the same constraints as before, it can be seen that this time V_ϕ decreases only slightly (see figure-b).

Finally, let the generator be loaded with leading-power-factor load. If new loads are added at the same power factor this time, the armature reaction voltage lies

outside its previous value, and V_ϕ actually *rises* (see figure c). In this last case, an increase in the load in the generator produced an increase in the terminal voltage.

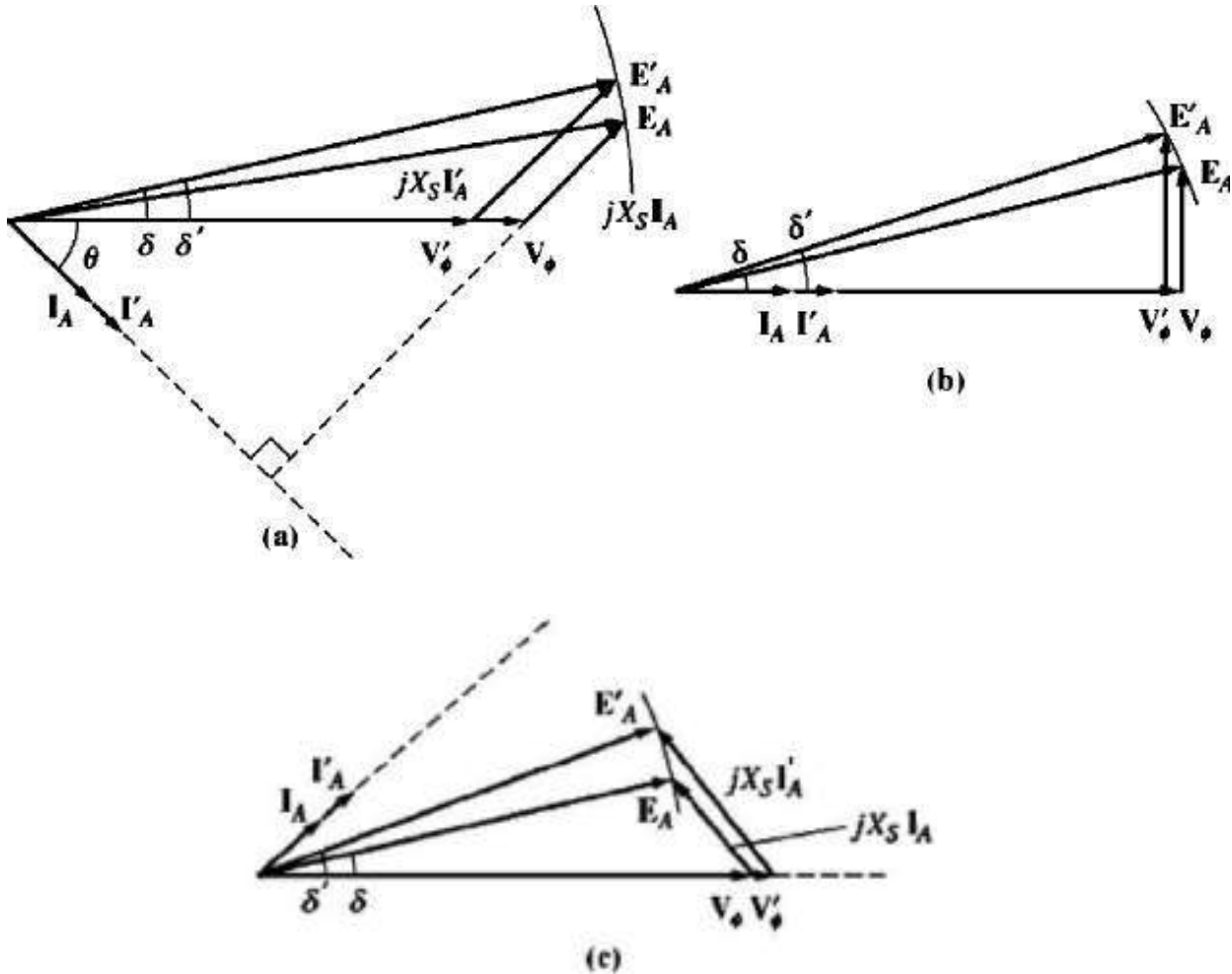

Figure: The effect of an increase in generator loads at constant power factor upon its terminal voltage (a) Lagging power factor (b) unity power factor (c) leading power factor

General conclusions from this discussion of synchronous generator behavior are:

1. If lagging loads (+Q or inductive reactive power loads) are added to a generator, V_ϕ and the terminal voltage V_T decrease significantly.
2. If unity-power-factor loads (no reactive power) are added to a generator, there

is a slight decrease in V_ϕ and the terminal voltage.

3. If leading loads (- Q or capacitive reactive power loads) are added to a generator, V_ϕ and the terminal voltage will rise.

Normally, it is desirable to keep the voltage supplied to a load constant, even though the load itself varies. To maintain the terminal voltage constant the obvious approach is to vary the magnitude of E_A , to compensate for changes in the load. Recall that $E_a = K \phi \omega$. Since the frequency should not be changed in a normal system, E_A can be controlled by varying the flux in the machine.

For example, suppose that a lagging load is added to a generator. Then the terminal voltage will fall, as was previously shown. To restore it to its previous level the field current is to be increased. An increase in I_f increases the flux, which in turn increases E_A and an increase in E_A increases the phase and terminal voltage.

The process can be reversed to decrease the terminal voltage. It is possible to regulate the terminal voltage of a generator throughout a series of load changes simply by adjusting the field current.

Synchronous Generators connected in parallel to an Infinite Bus:

It is an established practice these days to connect a number of synchronous generators in parallel to supply a common load. In power stations, instead of having one large capacity generator, a number of smaller units are installed and their output terminals connected in parallel. Moreover, for a variety of reasons, large number of stations in a country are interconnected through transmission and distribution lines and such a system is known as a Power Grid. All the synchronous generators of the system, therefore, work in parallel which is equivalent to a very large synchronous machine. Similarly all the electrical loads of the consumers are connected in parallel and form a very large variable load.

A supply system bus-bar with a large number of synchronous generators connected in parallel is referred to as an ***infinite bus-bar***. Any additional machine, whether to work as a generator or as a motor is connected in parallel with the system. The characteristics of an infinite bus-bar system are constant terminal

voltage, constant bus-bar frequency and very small synchronous impedance (since a large number of generators are in parallel). There are a number of advantages of connecting alternators in parallel to such an *infinite bus-bar* system.

Synchronizing Power & Torque:

A Synchronous Generator when synchronized to an infinite bus will tend to remain in synchronism for limited electrical and mechanical disturbances. The power angle characteristic of a cylindrical rotor synchronous generator is governed by the expression:

$$P = \left(\frac{EV}{X_s} \right) \sin \delta$$

Assume that the generator is supplying a load of P_0 with a load angle δ . Any sudden change of load on the generator will cause a momentary retardation of the rotor thereby increasing the load angle by $\Delta\delta$. This increase in δ will cause an increase in power output by ΔP which in turn will cause the rotor to oppose the increase in δ . The reverse will happen when δ will tend to decrease. The rotor will settle at its original load angle δ in an oscillatory manner. Therefore, ΔP caused by $\Delta\delta$ is the power that brings the machine back to its stable mode of operation.

The ratio $dP/d\delta$ is called the synchronising power coefficient or stiffness of the electromagnetic coupling and is an indicator of the capability of the synchronous machine to stay in synchronism i.e. the power required to correct a unit phase change is called synchronizing power and is given by:

Synchronising Power:

$$P_{syn} = \frac{dP}{d\delta} = \left(\frac{EV}{X_s} \right) \cos \delta \quad \text{Watt/elec. radian}$$

Synchronising power gives rise to a **synchronising torque** which is the Torque required to correct a unit phase change and given by:

Synchronising Torque:

$$T_{\text{syn}} = \frac{1}{\omega_s} \frac{dP}{d\delta} \text{ Nm/elec. radian}$$

where

$$\omega_s = \frac{2\pi N_s}{60}$$

From the expression for synchronising power, it is observed that P_{syn} is directly proportional to E and inversely proportional to synchronous reactance X_s . Machines with over excitation and small value of X_s will have high value of synchronizing power. Further, when value of δ is zero, P_{syn} is maximum and when δ is nearly 90° there is hardly any synchronising power or restoring action to counter the disturbances.

Machine Floats on a Bus-Bar: When synchronised, the generated emf of the incoming machine is just equal to the bus-bar voltage. The synchronous machine will be just floating on the bus-bar, i.e., it will neither deliver nor receive any power. The prime mover driving the machine will be supplying the no-load losses only.

Once a synchronous machine is synchronised, it will tend to remain in step with the other alternators. Any tendency to depart from the above condition is opposed by a **synchronising torque** (as explained above) developed due to a circulating current flowing through the alternators. The alternator, which due to some disturbances tends to speed up will develop a circulating current and power will flow from this alternator to the others, thereby having a loading effect on this advancing alternator. This will bring retarding action on its rotor and thus put it back in step with the other alternators. On the other hand, if any alternator tends to retard, power will flow from the other alternators to this alternator and the synchronising torque will tend to keep this machine in synchronism with the others.

Parallel Connection & Synchronizing of Alternators:

Before a synchronous generator is connected to a common **infinite bus bar** or a **Power Grid** or a **Set of already running Generators** to share the load it should be ensured that the following conditions are satisfied. Achieving the compliance of these conditions and then only adding an incoming Generator to the existing set

of Generators/Power Grid is called Synchronization of the new Generator with the already running Generators.

Advantages of Parallel Operation of Synchronous Generators:

The following are the advantages of connecting a large number of synchronous generators in parallel to supply a common load:

(a) Repair and maintenance of individual generators can be carried out effectively maintaining the continuity of supply by properly scheduling maintenance of generators one after the other. If only one large generator is installed, supply is to be cut off for maintenance work.

(b) For operating an alternator at maximum efficiency it is to be run near to its full-load capacity. It is uneconomical to operate large alternators on low loads. If several small units are used, units can be added or put off depending upon the load requirement and thus the units can be operated at or near to their rated capacity.

(c) Additional sets can be connected in parallel to meet the increasing demand, thereby reducing the initial capital cost of buying larger units in anticipation of increasing demands.

(d) There is physical and economic limit to the possible capacity of alternators that can be built. The demand of a single power station may be as high as 1200 MVA. It may not be feasible to build a single alternator of such a high rating due to physical and economic considerations.

(e) Having many generators increases the reliability of the power system, since the failure of anyone of them does not cause a total power loss to the load.

Conditions for Parallel Connection or Synchronization:

For satisfactory parallel connection of alternators, the following three conditions must be fulfilled:

(a) The generated voltage of the incoming alternator to be connected in parallel with a bus-bar should be equal to the bus-bar voltage.

Generated voltage of the incoming alternator can be adjusted by adjusting the field excitation.

(b) Frequency of the generated voltage of the incoming alternator should be equal to the bus-bar frequency.

Frequency of the incoming alternator can be controlled and made equal to bus-bar frequency by controlling the speed of the prime mover driving the incoming alternator.

(c) Phase sequence of the voltage of the incoming alternator should be the same as that of the bus-bar.

Phase sequence of the alternator and the bus-bar can be checked by a phase sequence indicator. Alternatively, a three lamps setup as shown in the figure below can be used for checking the phase sequence.

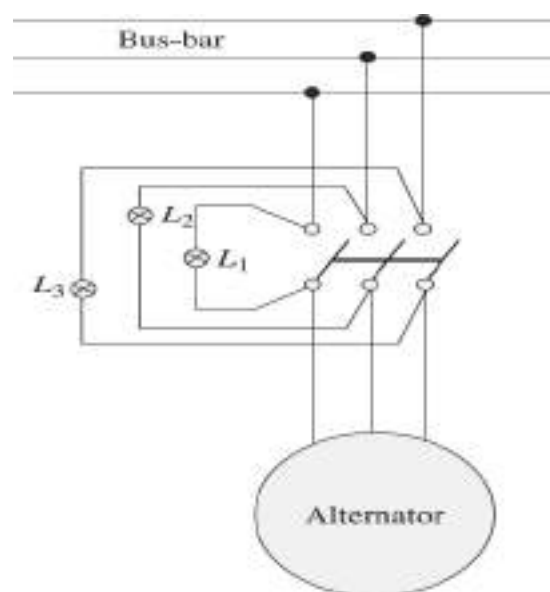

Figure: Three lamp method of checking the phase sequence of an alternator

Three lamps **L1**, **L2** and **L3** are connected as shown in the figure. When the synchronous generator is run at rated speed if all the lamps glow together and become dark together then the phase sequence of the incoming alternator is same as that of the bus-bar. Once the three conditions mentioned earlier are satisfied, the incoming alternator can be switched on to the bus bar **at the instant when the voltages of the incoming generator and the bus-bar are in exact phase**. For this purpose the two commonly used methods are described as follows.

1. A simple way is to observe the same three light bulb setup described above for checking the phase sequence. When all the three light bulbs become dark, the voltage difference across them is zero and the systems are in phase. This simple scheme works, but it is not very accurate. A better approach is to employ a synchroscope.

2. A *synchroscope* is a meter that measures the difference in phase angle between the **two sides of the same Phase (R_1R_2 , Y_1Y_2 or B_1B_2) of the two systems**. The face of a synchroscope is shown in the above figure. The dial shows the phase difference between any of the phase pairs mentioned above with 0° (meaning in phase at the top and 180° at the bottom). Since the frequencies of the two systems are slightly different, the phase angle on the meter changes slowly.

If the incoming generator frequency is higher than the running system (the desired situation), then the phase angle advances and the synchroscope needle rotates clockwise. If the incoming machine frequency is lower, the needle rotates counterclockwise. When the synchroscope needle is in the vertical position, the voltages are in phase, and the switch can be closed to connect the systems.

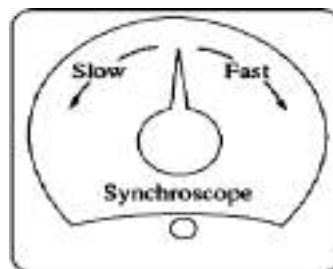

Figure: Front Panel of a Synchroscope

Notice that a *synchroscope* checks the relationship of phase angle on both sides of *only one phase*. It gives no information about phase sequence.

Active and Reactive Load Sharing:

A Synchronous Generator after synchronisation just floats on the bus-bar as explained above. It neither delivers power nor receives power. When a generator

is connected in parallel, it just shares a portion of the total load depending upon its kVA rating. We shall examine how load sharing of alternators running in parallel can be achieved. We will study the effect of change of excitation and that of prime-mover input.

Effect of Change of Excitation:

For DC generators, load sharing between a number of machines running in parallel can be achieved by adjusting their excitations. For synchronous generators, change of excitation, i.e., change of field current does not change the active power shared by them. Change of excitation only changes the reactive power supplied by each machine. This is explained with the help of a phasor diagram shown below. In this figure, V_B represents the bus-bar voltage and E_{in} is the voltage induced in the incoming machine. Since the incoming machine is connected in parallel, these two voltages are opposing each other as shown. When excitation of the incoming machine is changed to E'_{in} it will cause a resultant voltage, E_R to appear which will cause a current I_S to flow from the machine to the bus-bar, i.e., to the load. Current I_S will lag E_R by about 90° , because the synchronous reactance of the machine is much higher than its resistance. I_L is the current supplied to the load from the bus-bar and the total per phase power supplied is $V_B I_L \cos \phi_L$.

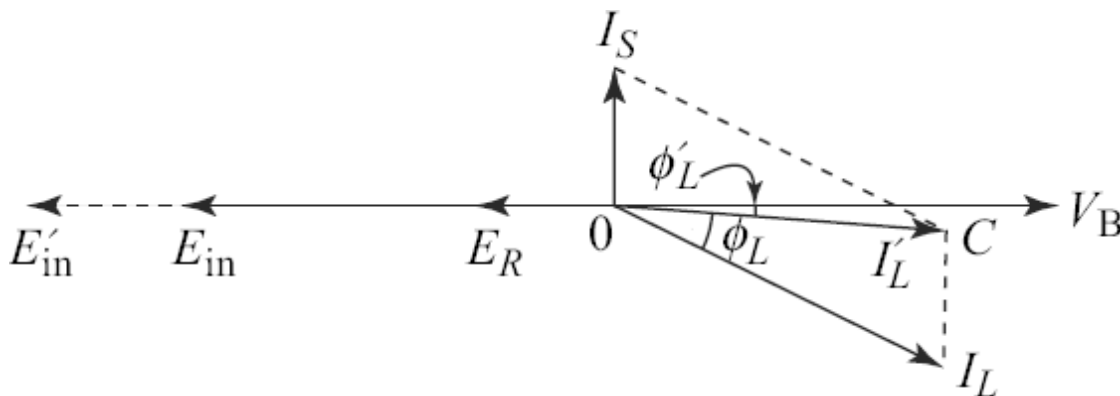

Figure: Effect of change of excitation of a synchronous machine connected in parallel with the bus-bar

Now the current supplied from the bus-bar is changed to I'_L since the incoming machine is supplying a reactive current, I_S . Since V_B is constant, active load power

is proportional to the length OC . The active power supplied by the existing machines connected to the bus-bar has not changed, i.e., the $I_L \cos \phi_L$ has remained equal to $I_L' \cos \phi_L'$. Change of excitation of the incoming machine has only changed the reactive power delivered by the existing machines.

Effect of Change of Prime mover Input:

If the input to the prime mover of the incoming generator is increased, it will start sharing the load while remaining in synchronism with the existing alternators connected to the bus-bar. Control of active power shared between the alternators is achieved by changing the input to their prime movers. Change in the input to prime movers in a thermal power station is achieved by a change of throttle opening and thus allowing more or less steam into the turbine, whereas in a hydel power station prime mover input is controlled by controlling the water inlet into the water turbine.

Let the prime mover input to the incoming alternator be increased. This will move the generated EMF phasor E_{in} forward as shown in the figure below.

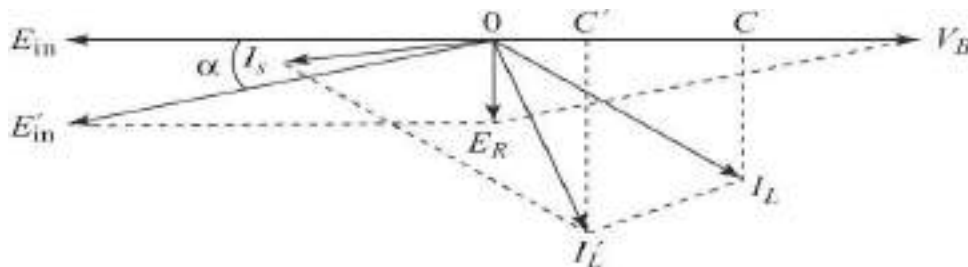

Figure: Effect of change of prime mover input to Synchronous Generator connected in parallel with the bus-bar

Let E' in be the new position of the generated **EMF** of the incoming alternator. The resultant voltage E_R will now cause a current I_s which has a strong in-phase component with the voltage. Thus the incoming machine will supply active power to the load. The I_L' will be the new load current supplied by the existing alternators, which has an active component represented by OC' . Thus, there is a reduction of active power load on the existing generators due to the sharing of active load by the incoming generator achieved by changing of prime mover input.

SYNCHRONOUS MOTORS

Theory of operation:

The basic concept of a synchronous motor is explained with the help of the figure below which shows a two-pole Synchronous Motor. The field current I_f of the motor produces a steady-state magnetic field B_R . A three-phase set of voltages is applied to the stator, which produces a three-phase current flow in the armature windings. This current flow produces a uniform rotating magnetic field B_S .

So there are now two magnetic fields present in the machine, and the *rotor field will tend to line up with the stator field*. Since the stator magnetic field is rotating, the rotor magnetic field (and the rotor itself) will constantly try to catch up with the rotating stator magnetic field. The larger the angle between the two magnetic fields (up to a certain maximum value), the greater the torque on the rotor of the machine. The basic principle of **synchronous motor** operation is that the rotor "chases" the rotating stator magnetic field around in a circle, never quite catching up with it but with the same speed.

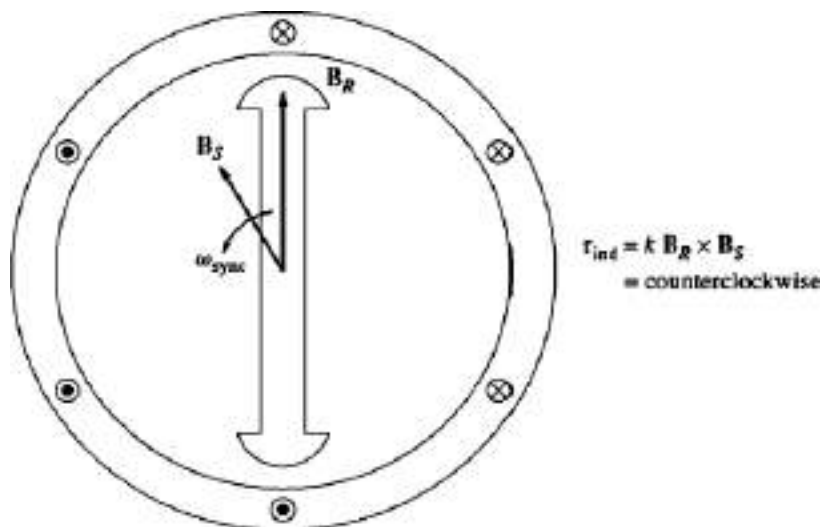

Figure: A two pole Synchronous Motor

Since a Synchronous Motor is the same physical machine as a Synchronous Generator, all the basic speed, power, and torque equations of synchronous Generators apply to Synchronous Motors also.

Equivalent Circuit of a Synchronous Motor

A synchronous motor is the same in all respects as a synchronous generator, except that the direction of power flow is reversed. Since the direction of power flow in the machine is reversed, the direction of current flow in the stator of the motor also is expected to reverse. Therefore, the equivalent circuit of a Synchronous Motor is exactly the same as the equivalent circuit of a Synchronous Generator, *except* that the reference direction of I_A is *reversed*. The resulting per phase equivalent circuit of a Synchronous Motor is shown in the figure below. Like in Generator, the three phases of the equivalent circuit may be either Y- or Δ connected.

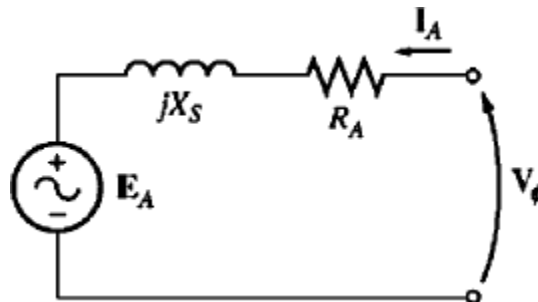

Figure: Equivalent circuit

Because of the change in direction of I_A , the Kirchhoff's voltage law equation for the equivalent circuit changes as below with just a reversal of sign on the current term.

$$\boxed{V_\phi = E_A + jX_S I_A + R_A I_A} \dots\dots\dots (1)$$

Or $\boxed{E_A = V_\phi - jX_S I_A - R_A I_A} \dots\dots\dots (2)$

The Synchronous Motor Phasor Diagrams:

To better understand synchronous motor operation let us once again look at a synchronous generator connected to an infinite bus. The generator has a prime mover turning its shaft, causing it to rotate. The direction of the applied torque

T_{app} from the prime mover is in the direction of motion, because the prime mover makes the generator rotate in the first place.

The phasor diagram of the generator operating with a large field current is shown in the figure (a) below along with the corresponding magnetic field diagram is shown in the figure(b) . As described before, B_R corresponds to (produces) E_A , B_{net} corresponds to (produces) V_ϕ , and B_S corresponds to $E_{Stat} (= -jX_S I_A)$. The direction of rotation of both the phasor diagram and magnetic field diagram is counterclockwise in the figure, following the standard mathematical convention of increasing angle.

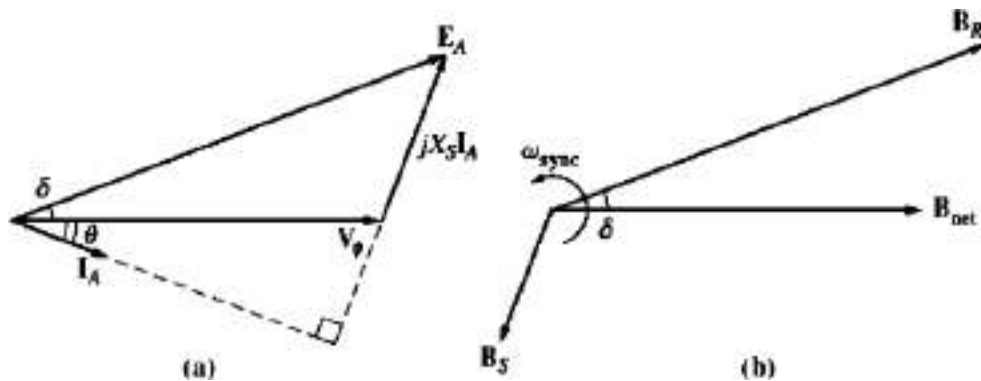

(a) Phasor diagram of a Synchronous Generator operating at a lagging power factor (b) Corresponding magnetic field diagram.

The induced torque in the generator can be found from the magnetic field diagram. From the fundamentals of AC Machines we know that the induced torque is given by:

$$T_{ind} = k B_R \times B_{net} \quad \dots (3)$$

$$T_{ind} = k B_R \times B_{net} \sin \delta \quad \dots (4)$$

Notice from the magnetic field diagram that *the induced torque in this machine is clockwise*, opposing the direction of rotation. In other words, the induced torque in the generator is a **counter torque**, opposing the rotation caused by the external applied torque T_{app} .

Now, suppose that, instead of turning the shaft in the direction of motion, the prime mover suddenly loses power and starts to drag on (follow on) the machine's shaft. Now the rotor slows down because of the drag on its shaft and

falls behind the net magnetic field in the machine as shown in the figure below. As the rotor, and therefore \mathbf{B}_R , slows down and falls behind \mathbf{B}_{net} , the operation of the machine suddenly changes. By Equation (3) above when \mathbf{B}_R is behind \mathbf{B}_{net} the induced torque's direction reverses and becomes counter clockwise. In other words, the machine's torque is now in the direction of motion, and the machine is acting as a motor.

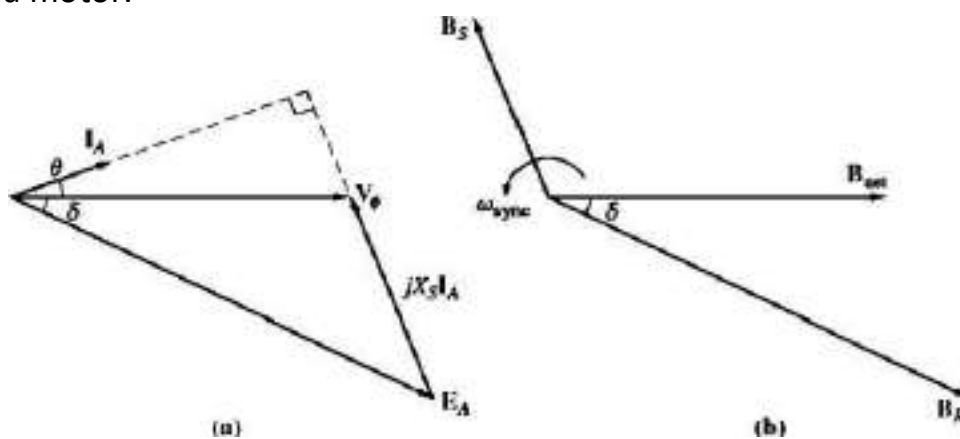

(a) Phasor diagram of a Synchronous Motor. (b) Corresponding magnetic field diagram.

The increasing torque angle δ results in a larger and larger torque in the direction of rotation, until eventually the motor's induced torque equals the load torque on its shaft. At that point, the machine will be operating at steady state and synchronous speed again, **but now as a motor**.

If we look closely at the phasor diagrams corresponding to generator operation and motor operation shown in the above figures we find that the quantity $j\mathbf{X}_s\mathbf{I}_A$ points from \mathbf{V}_ϕ to \mathbf{E}_A in the generator and from \mathbf{E}_A to \mathbf{V}_ϕ in the motor. The reason is that the reference direction of \mathbf{I}_A , was reversed in the definition of the motor equivalent circuit. The basic difference between motor and generator operation in synchronous machines can be seen both in the magnetic field diagram and in the phasor diagram. *In a generator, \mathbf{E}_A lies ahead of \mathbf{V}_ϕ and \mathbf{B}_R lies ahead of \mathbf{B}_{net} . In a motor, \mathbf{E}_A lies behind \mathbf{V}_ϕ and \mathbf{B}_R lies behind \mathbf{B}_{net} .* In a motor the induced torque is in the direction of motion and in a generator the induced torque is a counter torque opposing the direction of motion.

Steady-State Synchronous Motor operation:

This section explores the behavior of synchronous motors under varying conditions of load and field current as well as power-factor correction with synchronous motors. In the following studies, armature resistance of the motors is ignored for simplicity.

The Synchronous Motor Torque-Speed Characteristic Curve:

Synchronous motors supply power to loads that are basically constant-speed devices. They are usually connected to power systems *very* much larger than the individual motors, so the power systems appear as infinite buses to the motors. This means that the terminal voltage and the system frequency will be constant regardless of the amount of power drawn by the motor. The speed of rotation of the motor is locked to the applied electrical frequency, so the speed of the motor will be constant regardless of the load. The resulting torque-speed characteristic curve is shown in the figure below.

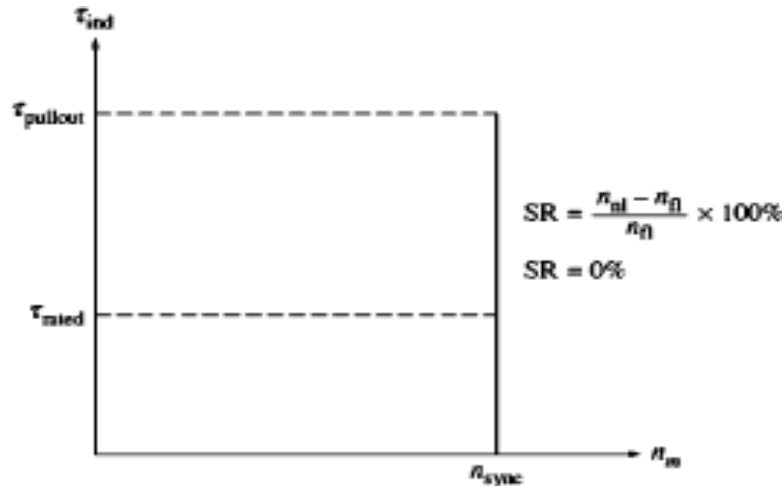

Figure: The Torque-Speed Characteristic of a Synchronous Motor. Since the speed of the Motor is constant, its speed regulation is '0' percent

The steady-state speed of the motor is constant from no load up to the maximum torque that the motor can supply (called the *pullout torque*). Hence the speed regulation of this motor is 0 percent. The torque equation is given by:

$$\tau_{\max} = kB_R B_{\text{net}}$$

$$\tau_{\max} = (3V_\phi E_A) / \omega_m X_S$$

These equations indicate that the larger the field current (and hence) the greater will be the maximum torque of the motor. There is therefore a stability advantage in operating the motor with a large field current or large E_A .

The Effect of Load Changes on a Synchronous Motor:

If a load is attached to the shaft of a synchronous motor, the motor will develop enough torque to keep the motor and its load turning at a synchronous speed. But now let us see what happens when the load is changed on a synchronous motor.

To find out, let us examine a synchronous motor operating initially with a leading power factor, as shown in the figure (a) below.

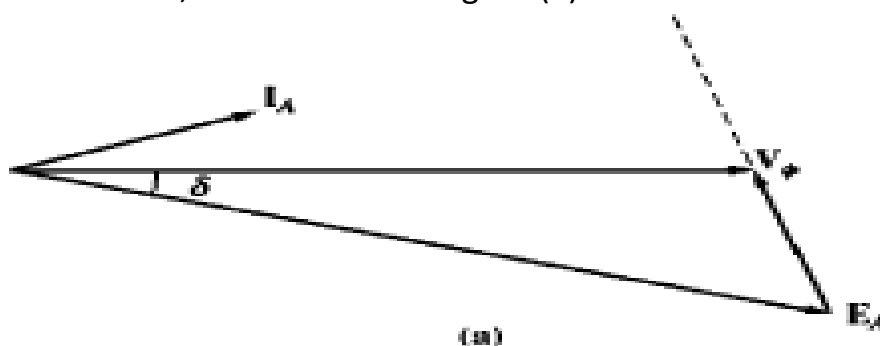

(a) Phasor diagram of a motor operating at a leading power factor

If the load on the shaft of the motor is increased, the rotor will initially slow down. As it does, the torque angle δ becomes larger, and the induced torque increases. The increase in induced torque speeds up the rotor back and the motor again turns at synchronous speed but with a larger torque angle δ .

Let us now see how the phasor diagram looks like during this process. To find out, let us examine the constraints on the machine during a load change. Figure (a) above shows the motor's phasor diagram before the load is increased. The

internal generated voltage E_A is equal to $K\phi\omega$ and so depends *only on* the field current in the machine and the speed of the machine. The speed is constrained to be constant by the input power supply, and since no one has touched the field circuit, the field current is constant as well. Therefore, $|E_A|$ *must be constant as the load changes*. The distances proportional to power ($E_A \sin \delta$ and $I_A \cos \phi$) will increase, but the magnitude of E_A must remain constant. As the load increases, E_A swings down in the manner shown in the figure (b) below.

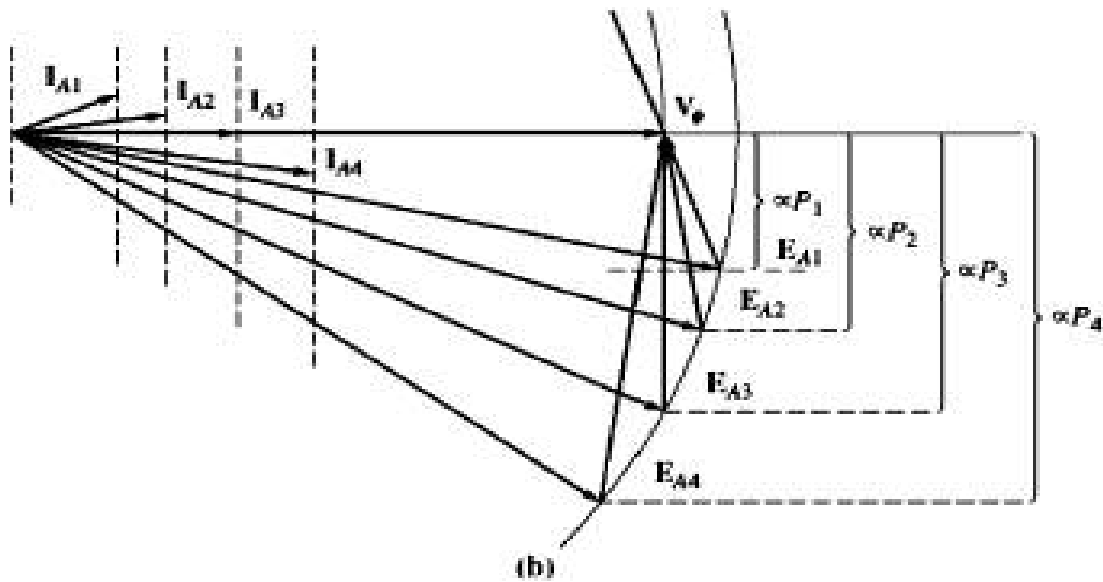

Figure (b): The effect of an increase in load on the operation of a synchronous motor.

As E_A swings down further and further, the quantity $jX_s I_A$ has to increase to reach from the tip of E_A to V_ϕ , and therefore the armature current I_A also increases. Notice that the power factor angle ϕ also changes, becoming lesser and lesser *leading* initially until it becomes 0° and then more and more *lagging*.

Effect of change of excitation on current and power factor of a Synchronous Motor driving a constant load:

When the load on a synchronous motor is constant, the input power $V_\phi I_A \cos \phi$ drawn from the bus-bar will remain constant. As the bus-bar voltage $V_\phi (E_A \sin \delta)$

is constant, $I_A \cos \phi$ will remain constant. Under this condition the effect of change of field excitation on the armature current I_A drawn by the motor and the power factor will be as follows:

Figure (a) below shows the phasor relationships between all the parameters viz. V_ϕ, E_A, I_A, ϕ and δ initially with a lagging power factor.

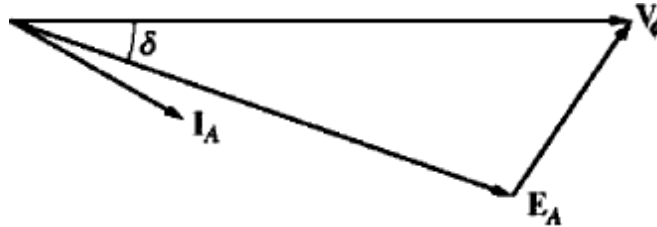

(a)

(a) A synchronous motor operating at a lagging power factor

We know that an *increase in field current increases the magnitude of E_A but does not affect the real power supplied by the motor.* The power supplied by the motor changes only when the shaft load torque changes. Let us understand this point with the help of the following phasor diagram/explanation.

Since a change in I_f does not affect the shaft speed n_m and since the load attached to the shaft is unchanged, the real power supplied is unchanged. But V_ϕ is also constant, since it is kept constant by the power source supplying the motor.

The distances proportional to power on the phasor diagram [$E_A \sin \delta(V_\phi)$ and $I_A \cos \phi$] must therefore be constant. When the field current is increased, E_A increases, but it can only do so by sliding out along the line of constant power. This effect is shown in the figure (b) below.

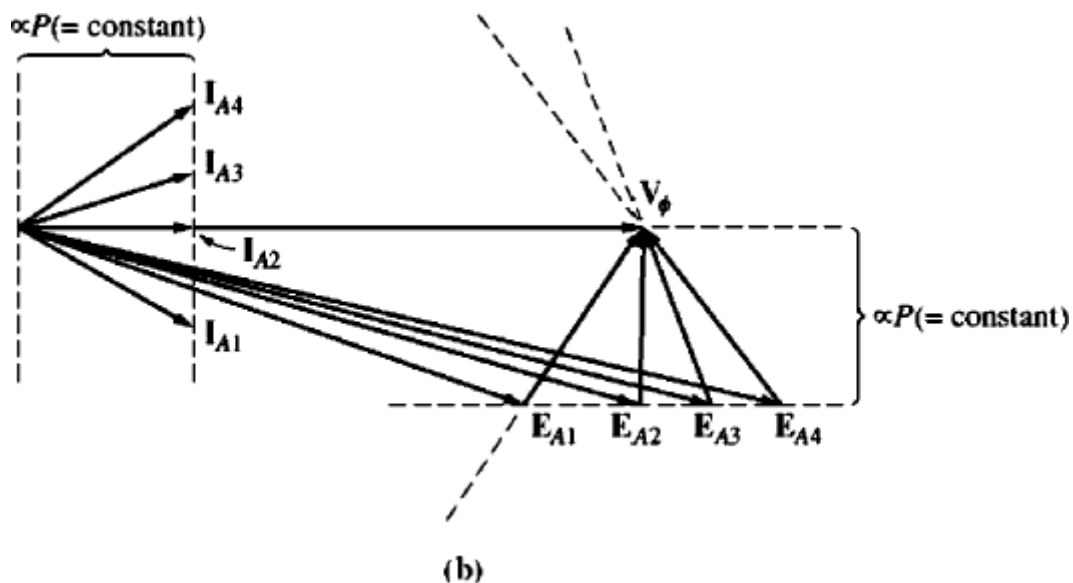

(b) The effect of an increase in field current of this motor

Notice that as the value of I_F increases, E_{A1} increases to E_{A2} and I_{A1} changes to I_{A2} . The magnitude of the armature current I_A first decreases and then increases again. At low E_A , the armature current is lagging and it is consuming reactive power Q . As the field current is increased, the armature current eventually lines up with V_ϕ corresponding to unity power factor and then as the field current is increased further, the armature current becomes leading, and the motor becomes a capacitive load. Effectively the motor is supplying reactive power Q to the system.

Figure below shows the effect of increase and decrease of excitation **on the magnitude and power factor of the current drawn by the motor in the form of a characteristic at a particular load**. It is seen that when the excitation is increased the motor draws a leading current.

In the figure below, at normal excitation, power factor is unity. The magnitude of armature current at this excitation is the minimum and is equal to OD . For excitation higher than the normal excitation, the magnitude of armature current will increase and the power factor will be leading. At excitation lower than the normal excitation, the magnitude of armature current will again increase but the power factor will be lagging as has been shown in the figure.

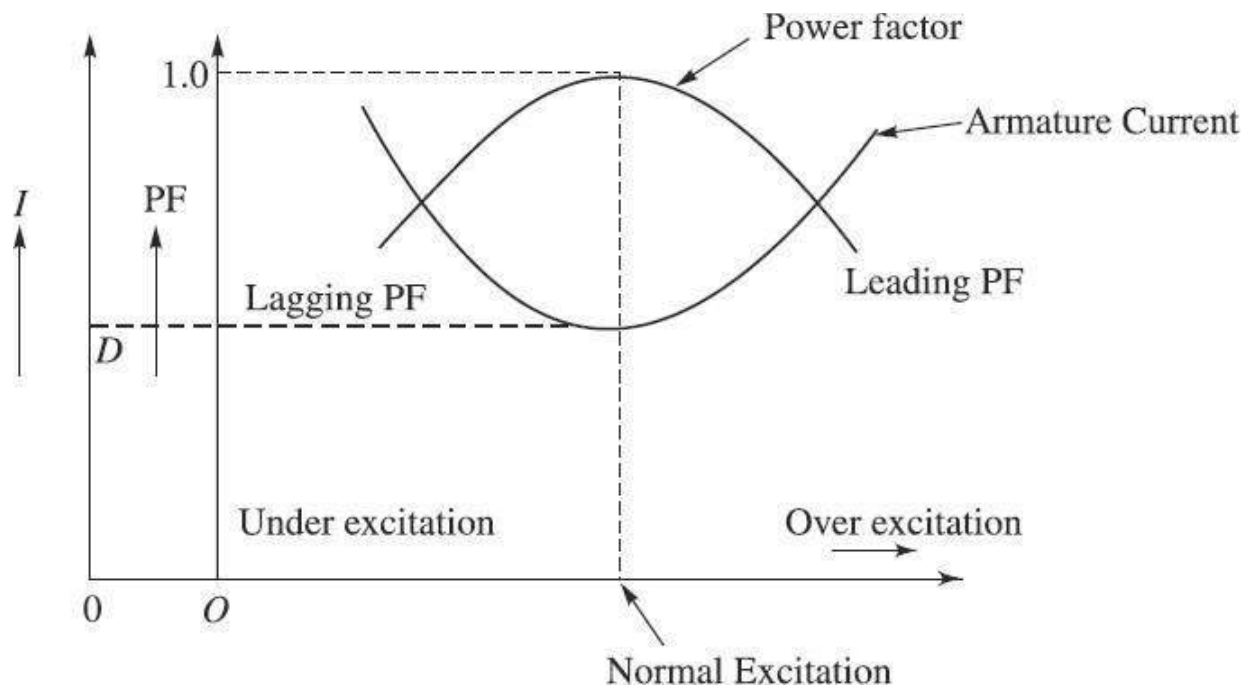

Figure: Effect of change of excitation on armature current and power factor of a synchronous Motor

The shape of the I_A versus I_f characteristic is similar to the letter **V** of the english alphabet and that is why this characteristic of synchronous motor is often referred to as synchronous motor **V-curve**. A series of **V-curves** can be obtained at various loads on the motor keeping each load constant at a particular value and changing the excitation from from under excitation to over excitation as shown in the figure below.

Since an overexcited synchronous motor, also called a synchronous condenser, draws leading power factor current, it can be used for power factor improvement in a power system (Power Grid).

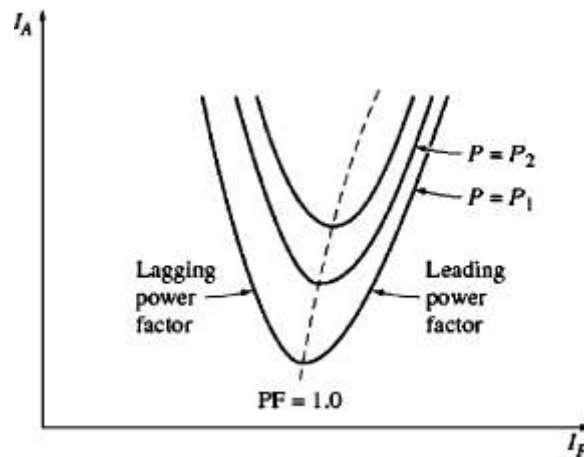

Figure: Synchronous Motor 'V' curves

Synchronous condenser:

- An over excited synchronous motor without a shaft extension, i.e., without any load on its shaft, used exclusively for power factor improvement in a power system, is called a **Synchronous Condenser**.
- Since an overexcited synchronous motor, draws leading power factor current, it can be used for power factor improvement in a power system (Power Grid).
- Installation of overexcited synchronous motors in parallel with the other loads will improve the power factor of the power system.
- Since it drives no load, it develops little torque and hence has a very light frame (very small size).
- Sometimes, an over excited Synchronous motor can be run with a small load also so that it can provide power factor improvement to the power system and drive some essential mechanical loads as well .

Let us refer to the 'V' curves of a Synchronous Motor i.e. a plot of I_A versus I_F shown in the figure below to and explain how it works.

There are several 'V' curves drawn, corresponding to different real power levels. For each curve, the minimum armature current occurs at unity power factor, when only real power is supplied to the motor. For field currents *less* than the value giving minimum I_A , the armature current is lagging, consuming reactive power Q . For field currents *greater* than the value giving the minimum I_A , the armature current is leading, supplying Q to the power system just like a capacitor.

Therefore, by controlling the field current of a synchronous motor, the *reactive power* supplied to or consumed by the power system can be controlled.

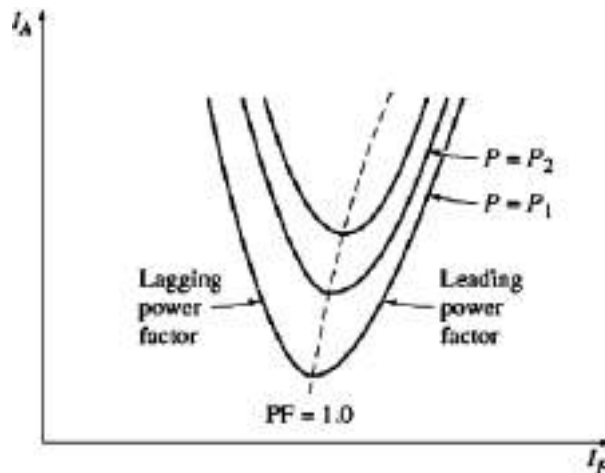
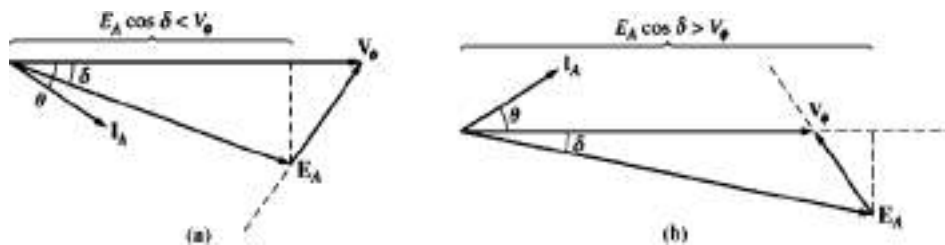

Figure: Synchronous Motor V curves

This can be better understood with reference to the phasor diagrams of a Synchronous motor shown below with lagging and leading power factors.



(a) The phasor diagram of an *under excited* synchronous motor. (b) The phasor diagram of an *over excited* synchronous motor.

- When the projection of the phasor E_A onto V_ϕ ($E_A \cos \delta$) is *shorter* than V_ϕ itself, a synchronous motor has a lagging current and consumes reactive power Q . Since the field current is small in this situation, the motor is said to be ***under excited***.
- On the other hand, when the projection of E_A onto V_ϕ is *longer* than V_ϕ itself, a synchronous motor has a leading current and supplies reactive power Q to the power system. Since the field current is large in this condition, the motor is said to be ***overexcited***.

Since now it is supplying reactive power to the Power system, it is working like a capacitor and improving the power factor of the system.

Hunting and its suppression:

A synchronous motor will be subjected to oscillations in speed when it is suddenly loaded or unloaded. The rotor speed changes momentarily until the torque angle δ adjusts itself to the new output requirement. If the load increases, the rotor slips backwards to an increased torque angle δ , while a load reduction causes the rotor to advance to a smaller torque angle position. But because of the moment of inertia, the rotor overshoots the final position, slowing down or speeding up more than the required value. Thus the rotor is subjected to periodic but momentary speed changes while the rotor is attempting to adjust to a correct torque angle, the average speed of the motor remaining constant. This quick forward and back ward motion of the rotor as it rotates at the average constant speed is called "*hunting*". The rotor is said to be hunting (i.e. in search of) for the correct torque angle in response to the changing load conditions.

Such an oscillation in speed produces undesirable current and torque pulsation. However, the squirrel cage winding made on the pole faces that provides the motor with its starting torque also dampens the oscillation in speed. Since, the damper winding is short-circuited in itself, there results a rotating mmf which in conjunction with the rotating field develops a damping torque, thus minimising oscillation.

The damper winding remains ineffective as long as the speed is constant at the synchronous speed.

Methods of Starting Synchronous Motors:

- In the earlier sections, the motor was always assumed to be initially rotating at *synchronous speed*. What has not yet been considered is the question: How did the motor go to synchronous speed in the first place?
- If three-phase supply is given to the stator phases of a stationary synchronous machine with the rotor excited, no steady starting torque will be developed. It would be instead a sinusoidally time-varying torque at the same frequency as

that of the supply frequency, the average value of which is zero. It is because the Rotor movement would be very small as compared to the movement of the rotating stator magnetic field and with the result, in the first half cycle if the torque developed is say CCW, then in the second half cycle torque developed would be in the CW direction. Hence, the rotor vibrates violently and gets overheated. That is the reason why a synchronous motor as such is not self-starting and needs additional means of starting to bring the rotor speed close to that of the stator rotating magnetic field. Once the speed of the rotor is close to that of the stator magnetic field, then the Rotor would catch up and move at the same speed as that of the stator RMF.

A Synchronous Motor can be started from its stationary condition by any the following methods:

- 1. Reduce the speed of the stator magnetic field** to a low enough value that the rotor can accelerate and lock in with it during one half-cycle of the magnetic field's rotation. This can be done by reducing the frequency of the applied electric power.
- 2. Use an external prime mover** to accelerate the synchronous motor up to synchronous speed, carry out the paralleling operation, and bring the machine on the line as a generator. Then, turning off or disconnecting the prime mover will make the synchronous machine run as a Synchronous machine.
- 3. Use damper windings or amortisseur windings:** The function of damper windings and their use in motor starting will be explained below.

Motor Starting by Reducing Electrical Frequency:

If the stator magnetic field in a synchronous motor rotates at a low enough speed, there will be no problem for the rotor to accelerate and to lock in with the stator magnetic field. The speed of the stator magnetic field can then be increased to the operating speed by gradually increasing frequency up to its normal 50 Hz value.

Though this method works well, in the earlier days before the development of Solid state electronics, getting a variable frequency source with rated voltages and power levels was very difficult. But now a days Solid state frequency converters are readily available meeting any of the technical requirements. With the development of such modern solid-state variable frequency drive packages, it is possible to continuously control the electrical frequency applied to the motor

all from a fraction of a hertz up to and above the full rated frequency. If such a variable-frequency drive unit is included in a motor-control circuit to achieve speed control, then starting the synchronous motor is very easy- simply adjust the frequency to a very low value for starting, and then raise it up to the desired operating frequency for normal running.

When a synchronous motor is operated at a speed lower than the rated speed, its internal generated voltage $E_A = K\phi\omega$ will be smaller than normal. If E_A is reduced in magnitude, then the terminal voltage applied to the motor must also be reduced to keep the stator current at a safe level. The voltage in any variable-frequency drive or variable-frequency starter circuit must vary roughly linearly with the applied frequency thus maintaining a constant v/f ratio.

Motor Starting with an External Prime Mover:

The second approach to starting a synchronous motor is to attach an external starting motor to it and bring the synchronous machine up to full speed with the external motor. Then the synchronous machine can be paralleled with its power system as a generator, and the starting motor can be detached from the shaft of the machine. Once the starting motor is turned off, the shaft of the machine slows down, the rotor magnetic field B_R falls behind B_{net} and the synchronous machine starts to act as a motor. Once paralleling is completed and motor starts running at synchronous frequency, the synchronous motor can be loaded as required.

Since most large synchronous motors have brushless excitation systems mounted on their shafts, it is often possible to use these exciters as starting motors.

For many medium-size to large synchronous motors, an external starting motor or starting by using the exciter may be the only possible solution, because the power systems they are tied to may not be able to handle the starting currents needed to use the amortisseur winding approach described next.

Motor Starting by Damper windings:

By far the most popular way to start a synchronous motor is to employ *damper* windings. They are special bars laid into slots carved in the face of a synchronous motor's rotor and then shorted out on each end by a large *shorting ring as shown in the figure below*.

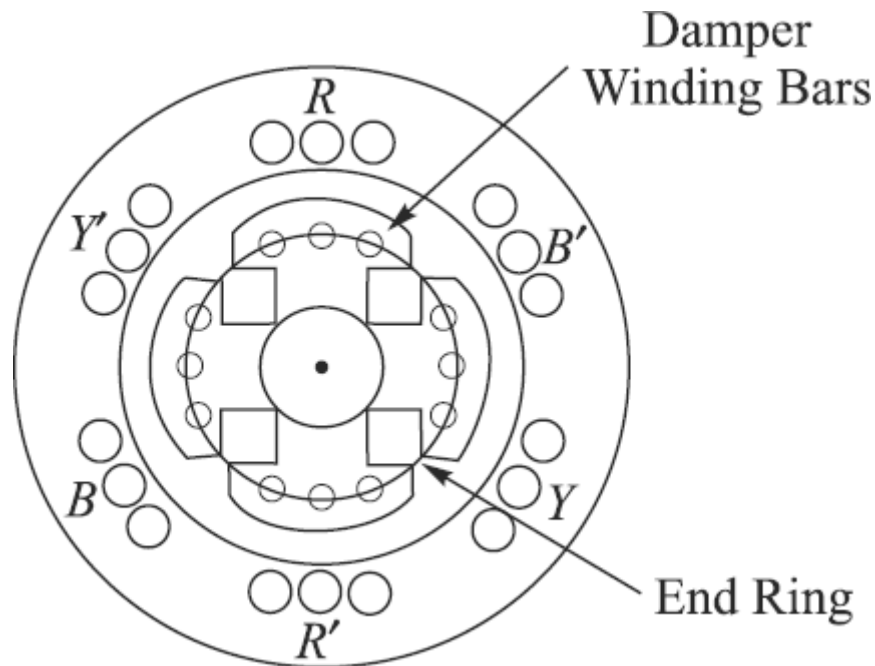

Figure: Damper windings provided on pole faces of a synchronous machine

As we know with such an arrangement, sometimes the torque is counter clockwise and sometimes it is essentially zero, but it is *always unidirectional*. Since there is a net torque in a single direction, the motor's rotor speeds up. (This is entirely different from starting a synchronous motor with its normal field current, since in that case torque is first clockwise and then counterclockwise, averaging out to zero. In this case, torque is *always* in the same direction, so there is a nonzero average torque.) On application of three-phase supply to the stator, a synchronous motor with damper winding will start as a three-phase induction motor and rotate at a speed near to synchronous speed. Now with the application of dc excitation to the field windings, the rotor will be pulled into synchronous speed since the rotor poles are now rotating at only slip-speed with respect to the stator rotating magnetic field.

In a real machine, the field windings are not open-circuited during the starting Procedure. If the field windings were open-circuited, then very high voltages would be produced in them during starting. If the field winding is short-circuited during starting, no dangerous voltages are produced, and the induced field current actually contributes extra starting torque to the motor.

To summarize, if a machine has *damper windings*, it can be started by the following procedure:

1. Disconnect the **field windings** from their DC power source and short them.
2. Apply a three-phase voltage to the stator of the motor, and let the rotor accelerate up to near-synchronous speed. The motor should have no load on its shaft, so that its speed can approach n_{sync} as closely as possible.
3. Connect the DC field circuit to its power source. After this is done, the motor will lock into step at synchronous speed, and loads may then be added to its shaft.

Important Questions:

1. Explain with the help of a Phasor diagram what is Power Angle and Torque Angle in a Synchronous Generator. Explain with the help of a plot how it varies with Power /Torque.
 2. Explain the Effect of Load Changes on a Synchronous Generator Operating Alone.
 3. Explain the concepts of an '*Infinite Bus*' and '*A Synchronous Generator Floats on the Bus*'.
 4. What are the Advantages of Parallel Operation of Synchronous Generators?
 5. (a)What are the conditions required to be fulfilled before paralleling a Generator to a Power Grid.
(b) Explain briefly how they are checked and confirmed.
 6. Explain the terms Synchronizing Power and Synchronizing Torque
 7. With the help of Phasor diagrams explain clearly the effect of change of excitation and change of Mechanical Input Power on the active and reactive load sharing of Generators running in parallel with a Power Bus.
 8. Explain the principle of operation of a Synchronous motor and draw its simple equivalent circuit.
 9. Draw and explain the phasor diagram of a Synchronous Motor comparing it with that of a Synchronous generator.
 10. Draw and explain the Torque - Speed characteristic of a Synchronous Motor.
 11. Explain the operation of a Synchronous motor with the help of a Phasor diagram for a varying load.
-

-
12. Explain the effect of change of excitation of a Synchronous Motor driving a constant load on the Armature current and power factor.
 13. Explain what is a Synchronous Condenser with the help of relevant plots and background theory.
 14. Explain what is hunting in a Synchronous Motor and the methods of its suppression.
 15. Why Synchronous Motors are not self starting? List out and explain the methods of starting Synchronous Motors.

UNIT-V

SINGLE PHASE & SPECIAL PURPOSE MOTORS

- Single phase Induction Motors
- Constructional Features
- Double Revolving Field Theory
- Split-Phase Motors
- Capacitor start Capacitor run motors
- Shaded pole motor
- Equivalent Circuit
- Principles of A.C. Series Motor & Universal motor
- Reluctance motor
- Hysteresis motor
- Stepper motor
- Brushless DC motor
 - Important Questions

Single Phase Induction Motors:

Single-phase induction motors are similar to three-phase induction motors except that the stator has a single-phase winding instead of a three-phase winding. Performance characteristics of single-phase induction motors are less satisfactory than three-phase induction motors. However, single-phase induction motors have found wide range of applications where only single-phase supply is available. Gradual improvements in design have made these motors quite satisfactory in fractional kilowatt ratings.

Constructional details:

A single-phase induction motor physically looks similar to a three-phase induction motor except that its **stator is provided with a single phase winding. The rotor construction is identical to that of a three phase squirrel cage induction motor.** There is no physical connection between the rotor and the stator and there is uniform air-gap between the stator and the rotor. The stator slots are distributed uniformly, and usually a single phase double-layer winding is used. A simple diagram showing the constructional features of a single phase Induction motor is shown in the figure below. A simple single-phase winding would not produce rotating magnetic field and hence no starting torque. It is, therefore, necessary to modify or split the stator winding into two parts, each part winding displaced in space on the stator to make the motor self-starting. Single-phase motors are classified into split-phase type, capacitor-type, and shaded-pole type depending upon the starting devices employed.

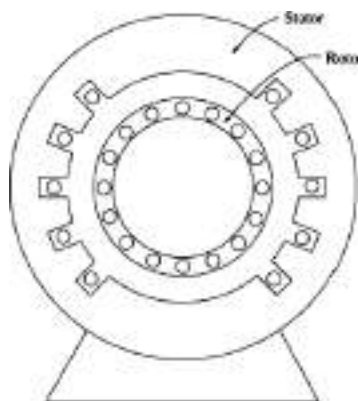

Figure: Construction of a single-phase induction motor.

Limitation of Single-Phase Induction Motors:

Since there is only one phase on the stator winding, the magnetic field in a single-phase induction motor does not rotate. Instead, it *pulsates*, getting first larger and then smaller, but always remains in the same direction. Because there is no rotating stator magnetic field, a single-phase induction motor has *no starting torque*.

This is easily seen from a motor when its rotor is stationary. The stator flux of the machine first increases and then decreases, but always points in the same direction. Since the stator magnetic field does not rotate, there is ***no relative motion*** between the stator field and the conducting bars of the rotor. But still a voltage is induced in the rotor bars by transformer action ($d\phi/dt$), and since the bars are short-circuited, current flows in the rotor. However, this magnetic field is lined up with the stator magnetic field but in an opposite direction, and it does not produce any net torque on the rotor as shown in the figure below.

$$\begin{aligned} \tau_{\text{ind}} &= k B_R \times B_S \\ &= k B_R B_S \sin \gamma \\ &= k B_R B_S \sin 180^\circ = 0 \end{aligned} \quad (1)$$

So effectively at stall conditions, the motor works like a transformer with a short-circuited secondary winding (see figure below)

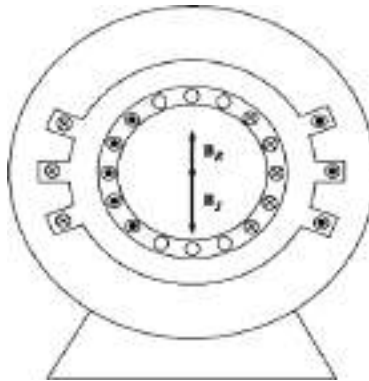

Figure: The single-phase induction motor at starting conditions. The stator winding induces opposing voltages and currents into the rotor circuit resulting in a rotor magnetic field *lined* up with the stator magnetic field but in opposite direction as in a Transformer. But $\tau_{\text{ind}} = 0$.

However, *once the rotor begins to run, torque will be produced in it.* There are two basic theories which explain why a torque is produced in the rotor once it starts running. (i) *Double-revolving-field theory* and (ii) *Cross-field theory*. We will study only *double-revolving-field theory*.

Double Revolving Field Theory:

This theory is based on the fact that the alternating field produced by the stator winding can be represented as the sum of two oppositely rotating fields of identical strength, each equal to one-half of the maximum field strength of the stator alternating field. The induction motor responds to each magnetic field separately, and the net torque in the machine will be the sum of the torques due to each of the two magnetic fields.

If these fields are represented by vectors that rotate in opposite directions as shown in the figure below, the summation of the vectors is a stationary vector that changes in length along the horizontal axis. In other words, as the alternating field ϕ_s oscillates between $+\phi_{sm}$ and $-\phi_{sm}$, the two component fields ϕ_f and ϕ_b rotate in the opposite directions but at the same speed. This is explained in detail as follows.

When single-phase supply is connected across the stator winding, an alternating field along the horizontal axis as shown in the figure (a) below will be produced. This field flux changes sinusoidally, because the stator current is sinusoidal. Stator field flux, ϕ_s can be represented by a vector whose value changes with time from $+\phi_{sm}$ to $-\phi_{sm}$ for each cycle of current flow through the stator winding. This alternating field can be resolved into two component fields ϕ_f and ϕ_b whose magnitudes are one-half of ϕ_{sm} but are shown rotating in opposite directions as the magnitude and direction of stator field changes with time.

If the component vectors are drawn for one cycle, it will be observed that each of the component flux vectors will rotate by one revolution. For a 50 Hz supply the component fields will rotate by 50 revolutions per second. In other words, it can be concluded that the component fields would rotate at synchronous speed but in opposite directions. The field, ϕ_f which rotates in clockwise direction can be termed as ***forward field*** and the field, ϕ_b which rotates in anticlockwise direction can be termed as ***backward field***.

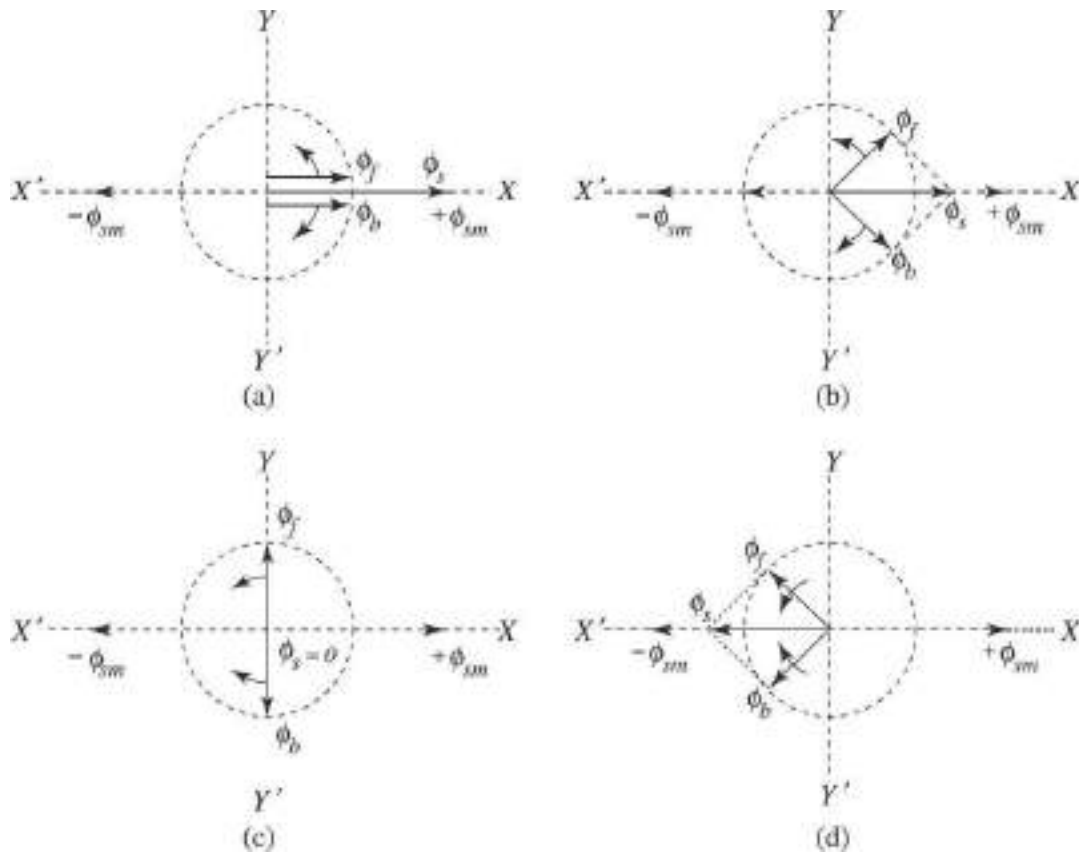

Figure: An alternating field is shown equivalent to two component revolving fields

The complete torque-speed curves corresponding to each of the component fields considered independently and also the net Torques are shown in the figure below. Note that for backward field the torque-speed curve is to be drawn in the reverse direction.

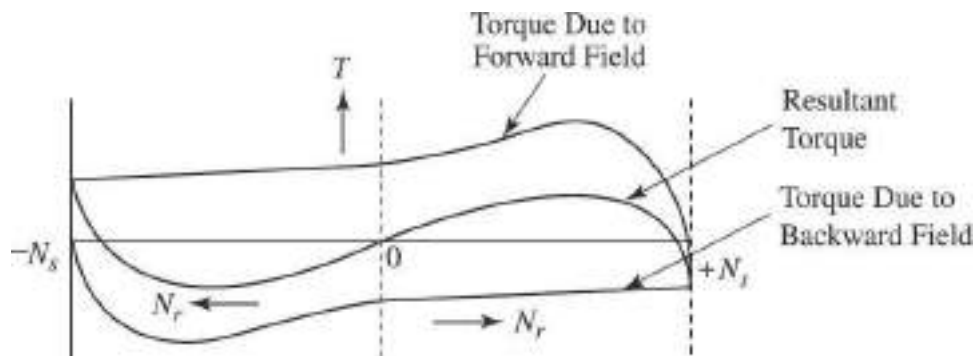

Figure: Torque-Speed Characteristic of a single-phase Induction Motor as derived from double revolving field theory

Torque developed by the two rotating fields are acting in opposite directions, each field develops a torque that tends to rotate the rotor in the direction in which that field rotates. The resultant torque developed on the rotor is the summation of the two torques produced by the two rotating fields. It may be noted that torque-speed curves have been drawn for a speed range of $-N_s$ to $+N_s$. The resultant torque-speed curve is also shown in the figure.

Summary points observed from the resultant torque-speed curve:

(a) Average torque at standstill is zero and, therefore, the motor is not self starting (at zero speed, torque developed by the forward and backward fields cancel each other).

(b) When the rotor is given an initial rotation in any direction, the average torque developed causes the rotor to continue to rotate in the direction in which it is given an initial rotation.

(c) The average torque becomes zero at some value of speed below the synchronous speed (whereas in a three-phase induction motor, torque is zero at synchronous speed). This indicates that a single-phase motor operates with a greater percentage of slip at full-load than a corresponding three-phase induction motor.

(d) To make the motor self-starting, some starting device or method will have to be employed. Single-phase induction motors are named according to the starting methods employed.

Starting of Single-Phase Induction Motors:

As we have studied, a single-phase induction motor has no intrinsic starting torque. There are three techniques commonly used to start these motors, and they are classified accordingly. The three major starting techniques are:

1. Split-phase windings
2. Capacitor-type windings
3. Shaded stator poles

All the three starting techniques are methods of making one of the two revolving magnetic fields in the motor stronger than the other and so giving the motor an initial nudge in one direction or the other.

Split-Phase Motors:

A split-phase motor is a single-phase induction motor with two stator windings, a Main stator winding (**M**) and an Auxiliary starting winding (**A**) as shown in the figure below. These two windings are set 90 degrees apart along the stator of the motor, and the auxiliary winding is designed to be switched out of the circuit at some set speed by a centrifugal switch. The auxiliary winding is designed to have a higher resistance/reactance ratio than the main winding, so that the current in the auxiliary winding *leads* the current in the main winding. [This higher **RIX** ratio is usually accomplished by using smaller (thinner) wire for the auxiliary winding. Thinner wire is permissible in the auxiliary winding because it is used only for starting and therefore does not have to take full current continuously]

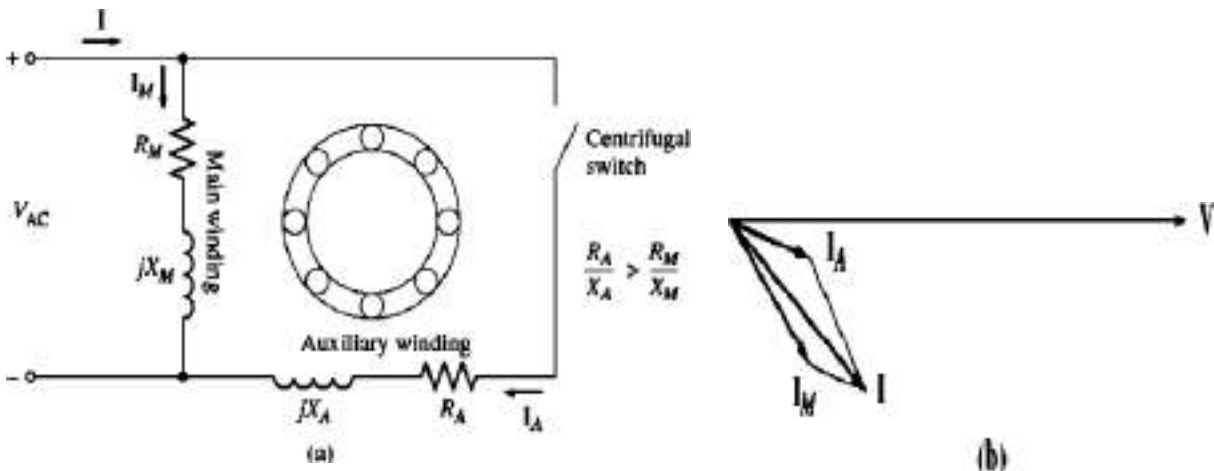
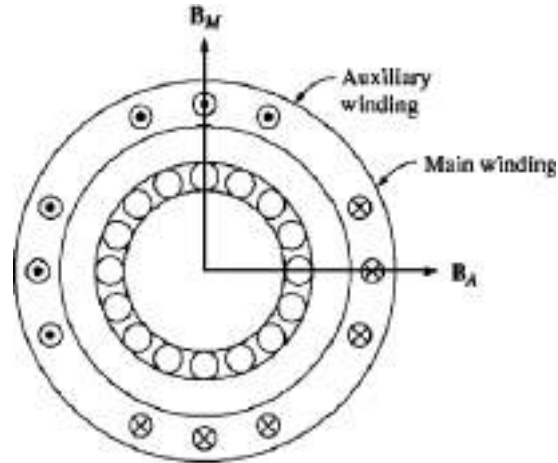

Figure: (a) A split-phase induction motor. (b) The currents in the motor at starting conditions.

To understand the function of the auxiliary winding, refer the figures (a) and (b) below. Since the current in the auxiliary winding leads the current in the main winding, the magnetic field B_A peaks before the main magnetic field B_M .

Since B_A peaks first and then B_M , there is a net counterclockwise rotation in the magnetic field. In other words, the auxiliary winding makes one of the oppositely rotating stator magnetic fields larger than the other one and provides a net starting torque to the motor.

A typical Torque-Speed Characteristic is shown in the figure (c) below.



(a)

Figure (a) Relationship of main and auxiliary magnetic fields

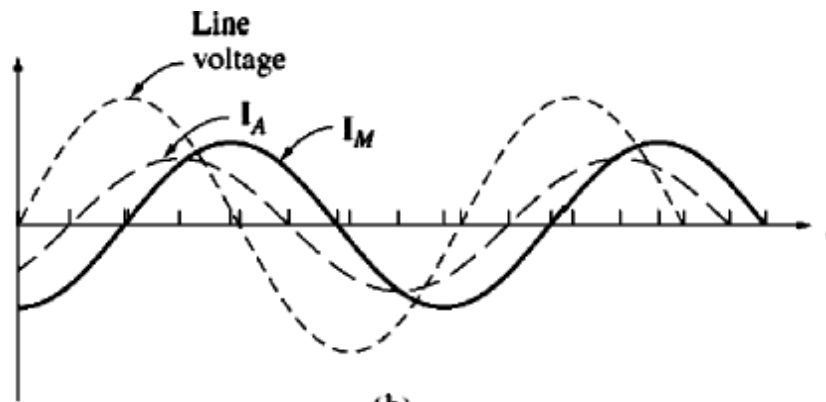

(b)

Figure (b): I_A peaks before I_M , producing a net Counter clockwise rotation of the magnetic fields

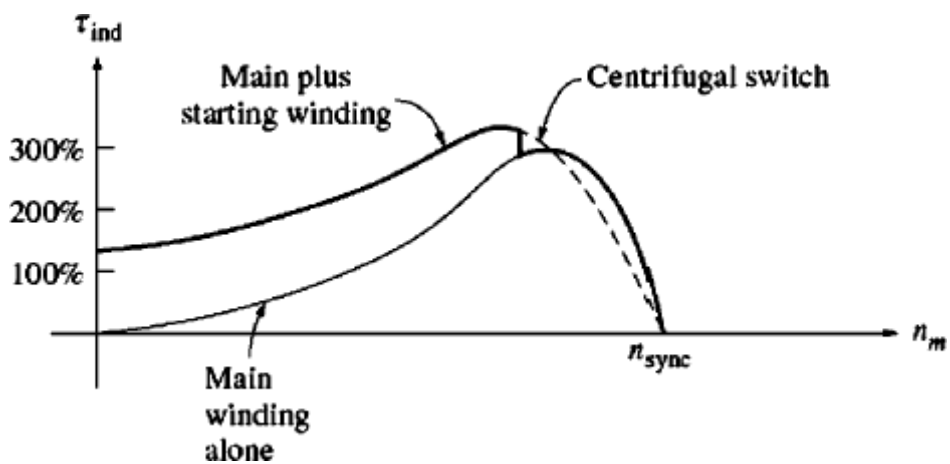

Figure (c): The resulting torque-speed characteristic.

Split-phase motors have a moderate starting torque with a fairly low starting current. They are used for applications which do not require very high starting torques, such as fans, blowers, and centrifugal pumps. They are available for sizes in the fractional-horsepower range and are quite inexpensive.

In a split-phase induction motor, the current in the auxiliary windings always peaks before the current in the main winding, and therefore the magnetic field from the auxiliary winding always peaks before the magnetic field from the main winding. The direction of rotation of the motor is determined by whether the space angle of the magnetic field from the auxiliary winding is 90° ahead or 90° behind the angle of the main winding. Since that angle can be changed from 90° ahead to 90° behind just by switching the connections on the auxiliary winding, ***the direction of rotation of the motor can be reversed by switching the connections of the auxiliary winding*** while leaving the main winding's connections unchanged.

Capacitor-Start Motors:

For some applications, the starting torque supplied by a split-phase motor is insufficient to start the load on a motor's shaft. In such cases, capacitor-start motors are used. In a capacitor-start motor, a capacitor is placed in series with the auxiliary winding of the motor as shown in the figure below.

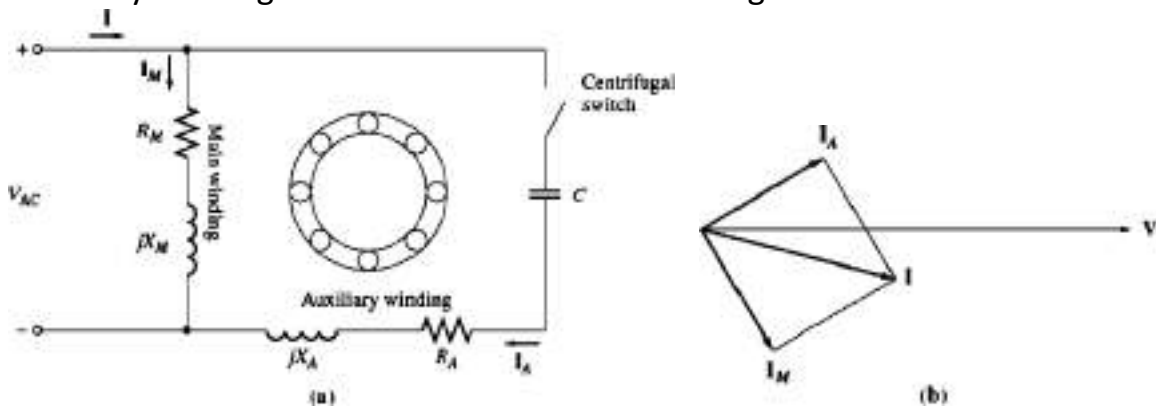

Figure: (a): A capacitor-start Induction Motor (b) Current angles at starting

By proper selection of capacitor size, the **mmf** of the starting current in the auxiliary winding can be adjusted to be equal to the **mmf** of the current in the main winding, and the phase angle of the current in the auxiliary winding can be made to lead the current in the main winding by 90° . Since the two windings are physically separated by 90° , a 90° phase difference in current will yield a single

uniform rotating stator magnetic field, and the motor performs just as a three-phase motor. In this case, the starting torque of the motor can be more than 300 percent of its rated value as shown in the figure below.

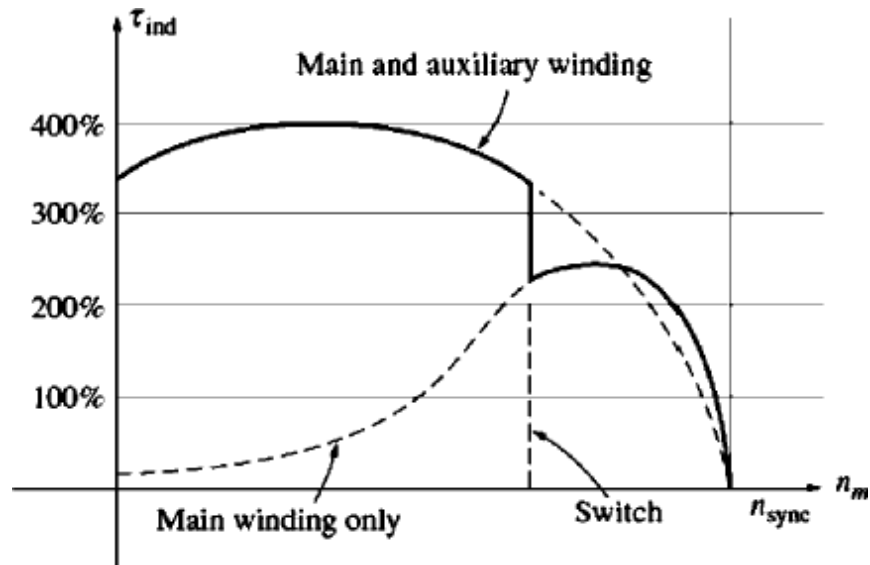

Figure: Torque-Speed characteristic of a capacitor-start Induction Motor.

Permanent Split-Capacitor Motors:

With a starting capacitor, the torque-speed characteristics of an induction motor are so good that an auxiliary winding with a smaller capacitor is sometimes left permanently in the motor circuit. If the capacitor's value is chosen correctly, such a motor will have a perfectly uniform rotating magnetic field at some specific load, and it will behave just like a three-phase induction motor at that point. Such a design is called a **permanent split-capacitor** or **capacitor-start and run** motor and is shown in the figure below. Permanent split-capacitor motors are simpler than capacitor-start motors, since the starting switch is not needed. At normal loads, they are more efficient and have a higher power factor and a smoother torque than ordinary single-phase induction motors.

However, permanent split-capacitor motors have a *lower starting torque* than capacitor-start motors, since the capacitor must be sized to balance the currents in the main and auxiliary windings at normal-load conditions. Since the starting current is much greater than the normal-load current, a capacitor that balances the phases under normal loads leaves them unbalanced under starting conditions.

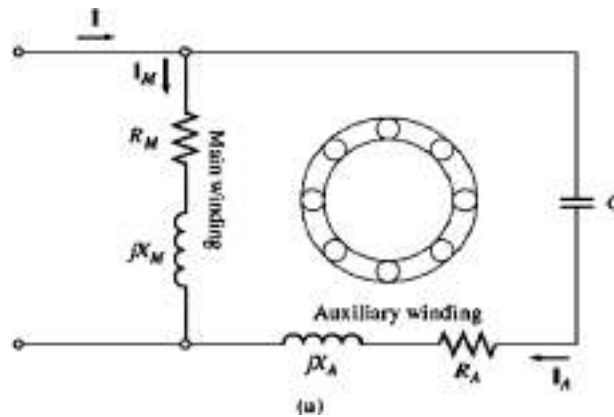

Figure (a): A permanent split-capacitor Induction Motor

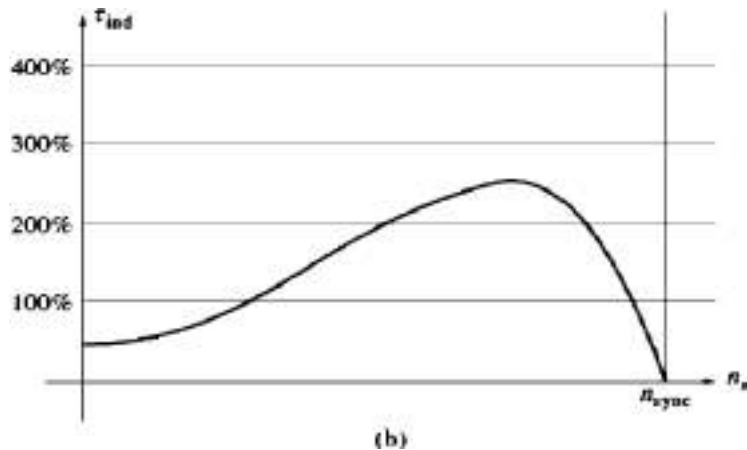

Figure (b): Torque-speed characteristic of this motor

Capacitor-Start, Capacitor-Run Motors:

If both the largest possible starting torque and the best running conditions are needed, two capacitors can be used with the auxiliary winding as shown in the figure below. Such motors with two capacitors are called **capacitor-start, capacitor-run** or **two-value capacitor** motors. The larger capacitor is present in the circuit only during starting when it ensures that the currents in the main and auxiliary windings are roughly balanced, yielding very high starting torques. When the motor picks up the required speed, the centrifugal switch opens, and the permanent capacitor is left as such in the auxiliary winding circuit. The permanent capacitor is just large enough to balance the currents at normal motor loads, so

that the motor again operates efficiently with a sufficiently high torque and power factor.

The direction of rotation of any capacitor-type motor may be reversed by switching the connections of its auxiliary windings.

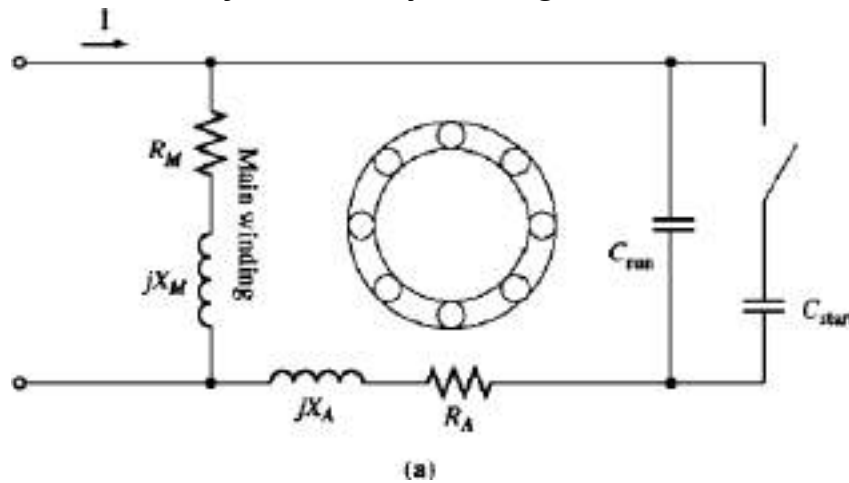

Figure (a): A capacitor-start, Capacitor-run Induction Motor

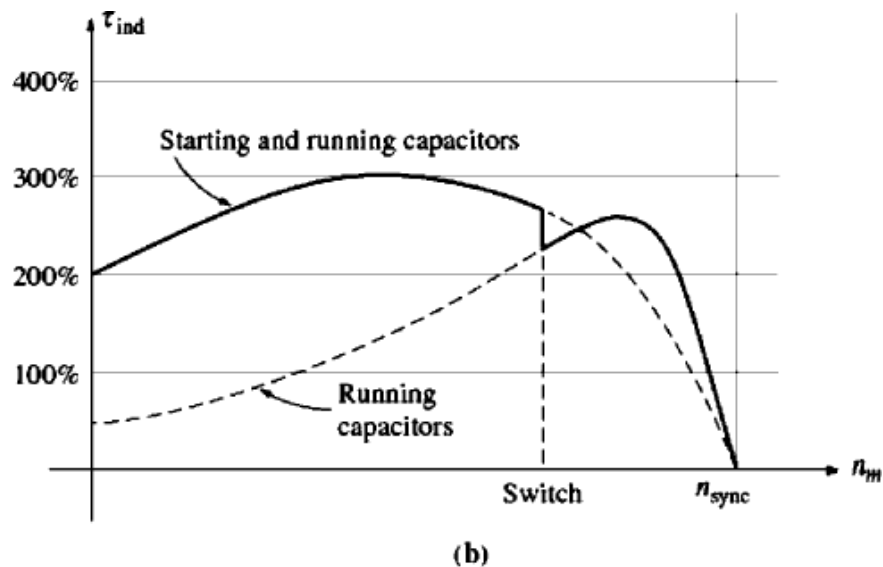

Figure (b): Torque-speed characteristic of this motor

Shaded - Pole Motors:

A shaded-pole induction motor is an induction motor with only a main winding. Instead of having an auxiliary winding, it has salient poles, and one portion of

each pole is surrounded by a short-circuited coil called a **shading coil** as shown in the figure below.

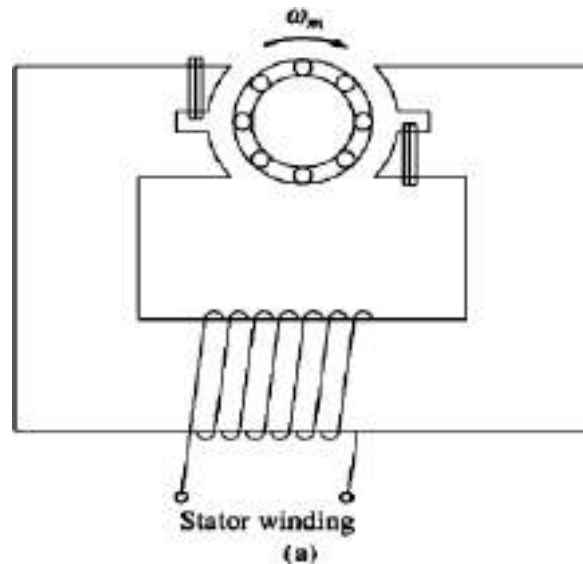

Figure (a): A basic Shaded-Pole Induction Motor

A time-varying flux is induced in the poles by the main winding. When the pole flux varies, it induces a voltage and a current in the shading coil which **opposes** the original change in flux. This opposition **retards** the flux changes under the shaded portions of the coils and therefore produces a slight imbalance between the two oppositely rotating stator magnetic fields. The net rotation is in the direction from the unshaded to the shaded portion of the pole face. The Torque-Speed characteristic of a shaded-pole motor is shown in the figure below.

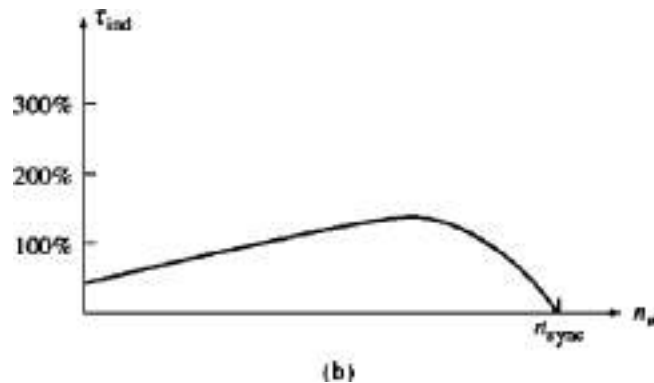

Figure (b): The resulting torque-speed characteristic. of a Shaded pole motor

Shaded poles produce less starting torque than any other type of Induction Motor starting systems. They are much less efficient and have a much higher slip than other types of single-phase induction motors. Such poles are used only in very

small motors with very low starting torque requirements. Where it is possible to use them, shaded-pole motors are the cheapest design available.

Because shaded-pole motors rely on a shading coil for their starting torque, there is no easy way to reverse the direction of rotation of such a motor. To achieve reversal, it is necessary to install two shading coils on each pole face and to selectively short one or the other of them.

Comparison of Single-Phase Induction Motors:

Single-phase induction motors may be ranked in terms of their Good Starting and Running characteristics as below:

1. Capacitor-start, capacitor-run motor
2. Capacitor-start motor
3. Permanent split-capacitor motor
4. Split-phase motor
5. Shaded-pole motor

Equivalent Circuit of a Single-Phase Induction Motor:

Let us develop the equivalent circuit based on the double-revolving-field theory that too only a special case of that theory. Because developing the equivalent circuit with both main and auxiliary windings is beyond the scope at present we will develop when the *main winding* alone is operating.

Let us begin when the motor is in stalled condition. At that time, the motor appears to be just a single-phase transformer with its secondary circuit shorted, and so its equivalent circuit is that of a transformer. This equivalent circuit is shown in the figure below. In this figure, R_1 and X_1 are the resistance and reactance of the stator winding, X_M is the magnetizing reactance, and R_2 and X_2 are the referred values of the rotor's resistance and reactance to the stator. The core losses of the machine are not shown and will be lumped together with the mechanical and stray losses as a part of the motor's rotational losses.

Now recall that the pulsating air-gap flux in the motor at stall conditions can be resolved into two equal and opposite magnetic fields within the motor. Since these fields are of equal size, each one contributes an equal share to the resistive and reactive voltage drops in the rotor circuit. It is possible to split the Rotor

Equivalent circuit into two sections, each one corresponding to the effects of one of the magnetic fields. The motor equivalent circuit with the effects of the forward and reverse magnetic fields separated is shown in the subsequent figure below.

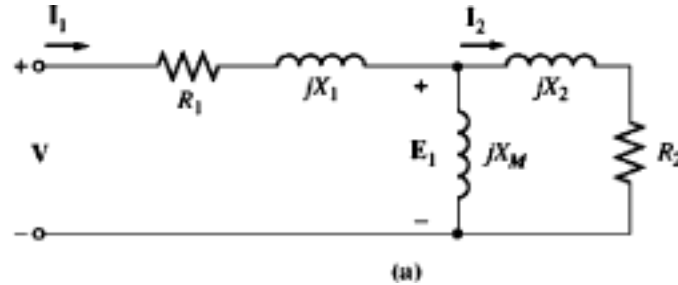

Figure (a): The equivalent circuit of a single-phase induction motor at standstill when its Main Windings alone are energized.

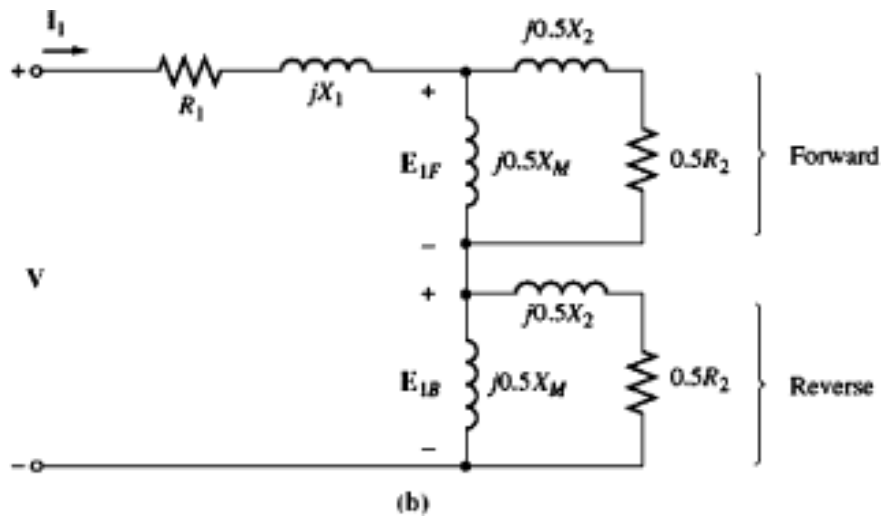

Figure (b): The equivalent circuit with the effects of the forward and reverse magnetic fields separated.

Now suppose that the motor's rotor begins to run with the help of an auxiliary winding and that the winding is switched out again after the motor comes up to speed. As we know, the effective rotor resistance of an induction motor depends on the amount of relative motion between the rotor and the stator magnetic fields. However, there are two magnetic fields in this motor, and the amount of relative motion differs for each of them.

For the **forward** magnetic field, the per-unit difference between the rotor speed and the speed of the magnetic field is the slip 's', where slip is defined in the same manner as it was for three-phase induction motors. The rotor resistance in the part of the circuit associated with the forward magnetic field is thus $0.5R_2/s$.

The forward magnetic field rotates at speed n_{sync} and the reverse magnetic field rotates at speed $-n_{sync}$. Therefore, the total per-unit difference in speed (on a base of n_{sync}) between the forward and reverse magnetic fields is **2**. Since the rotor is running at a speed 's' slower than the forward magnetic field, the total per-unit difference in speed between the rotor and the reverse magnetic field is **(2 - s)**. Therefore, the effective rotor resistance in the part of the circuit associated with the reverse magnetic field is $0.5R_2/(2 - s)$.

The final induction motor equivalent circuit is shown the figure below.

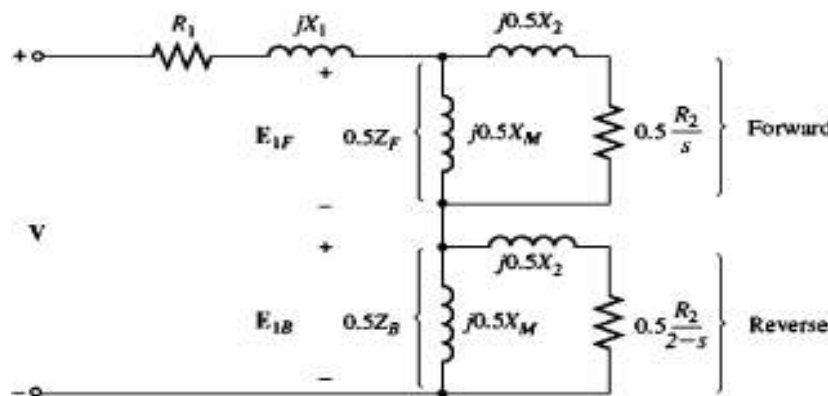

Figure: The equivalent circuit of a single-phase induction motor in running condition with only its main windings energized.

AC Series Motor:

In a DC series motor, the armature and the field terminals are connected in series. When a DC series motor is connected across an ac supply, the polarity of both the armature and the field changes every half cycle. The direction of torque developed and the direction of rotation of the rotor, therefore, remains unaltered as shown in the figure below.

But in actual practice, following **operating problems** arise when a DC series motor is allowed to work on AC supply.

(a) Because of the increase in hysteresis and eddy-current losses due to the alternating flux created by ac supply, efficiency of the motor will be poorer.

(b) Considerable sparking at the brushes will occur because in addition to the causes of sparking that occurs in a DC motor, transformer action on coil undergoing commutation further intensifies commutation difficulties. The coil, short-circuited by the brushes, links part of the constantly changing main field flux, and hence a voltage is induced in it.

(c) Power factor of the motor will be less. This is because of the inductive reactance of the field and armature winding.

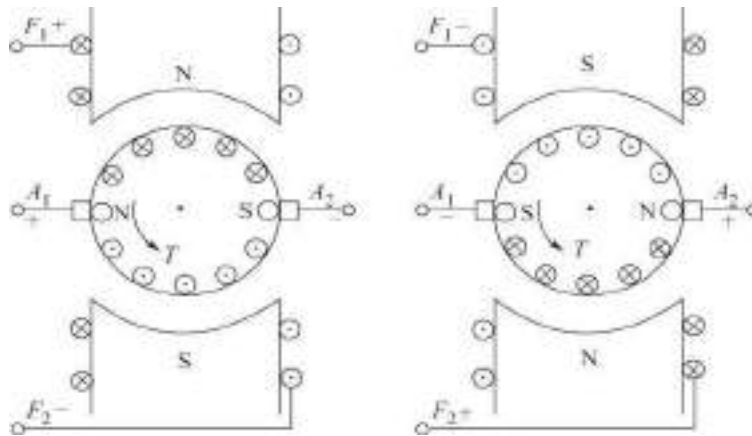

Figure: No change in the direction of rotation takes place when the polarities of both armature and field terminals of a DC motor are reversed

Design Considerations for an AC Series Motor:

To enable a DC series motor operate satisfactorily on AC supply, the following modifications in the design are to be incorporated.

(a) The yoke and the poles should be completely laminated to minimize the eddy current losses.

(b) The field is to be wound with fewer turns than a DC motor. The field pole area is to be increased so that the field is operated at a comparatively low flux density. This will reduce the iron-loss and reactive voltage drop. In order to obtain the required torque with this low field flux, the number of armature coils should be increased.

(c) Voltage induced by transformer action in a coil undergoing commutation may be minimised, somewhat by constructing the armature coils with fewer turns. Sometimes even a single turn armature coil may be used.

[(d) Increased number of armature coils will increase the armature reaction and may cause more commutation problems. More number of armature coils will increase the armature reactance also. To reduce the effect of armature reaction and thereby improving commutation and to reduce armature reactance a compensating winding may be used. The compensating winding as shown in the figure below is placed on the stator slots at 90° electrical with the main field axis. It may be connected in series with the armature and field winding or may be short circuited in itself. Since the axis of the compensating winding coincides with the brush axis, the alternating flux of the armature induces an emf in the short circuited winding. The current in the winding due to this induced emf opposes the flux causing it and hence it opposes the armature reaction]

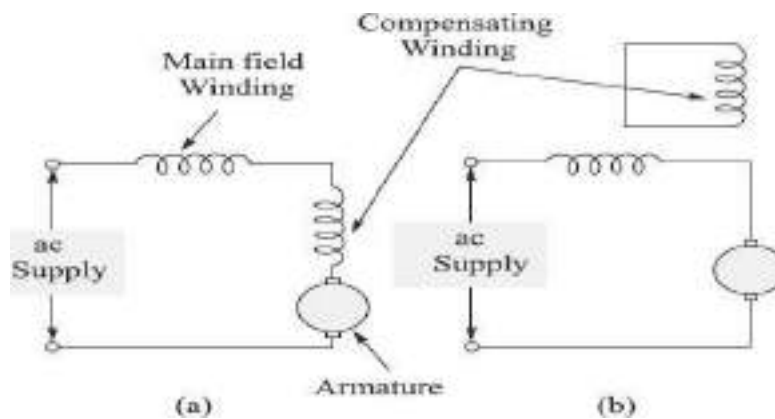

Figure: Single-phase Series Motor with compensating winding

Torque-speed Characteristics and Applications: The torque-speed characteristics of an AC series motor is similar to that of a DC series motor as shown in the figure below. Because of high starting torque developed, ac series motors are used in railway systems for electric locomotives.

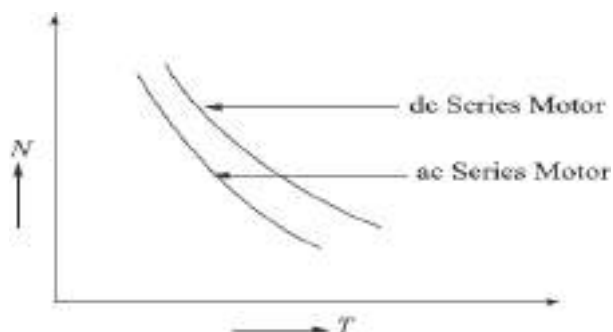

Figure: Torque Speed characteristics of Series Motors

Reluctance Motor:

Single-phase induction motors built with variable air-gap reluctance and with no DC supply on the rotor are called reluctance motors. Such motors start just as single phase induction motors but are pulled into synchronous speed due to the variation in air-gap reluctance. This pull-in force on such motors is based on the reluctance principle as explained follow:

Let us consider a piece of magnetic material, free to rotate, placed in a magnetic field as shown below. A torque will act on the material shown in figure (a) to bring it to the position shown in figure (b), so as to give minimum magnetic reluctance path to the flow of flux from North Pole to the South Pole.

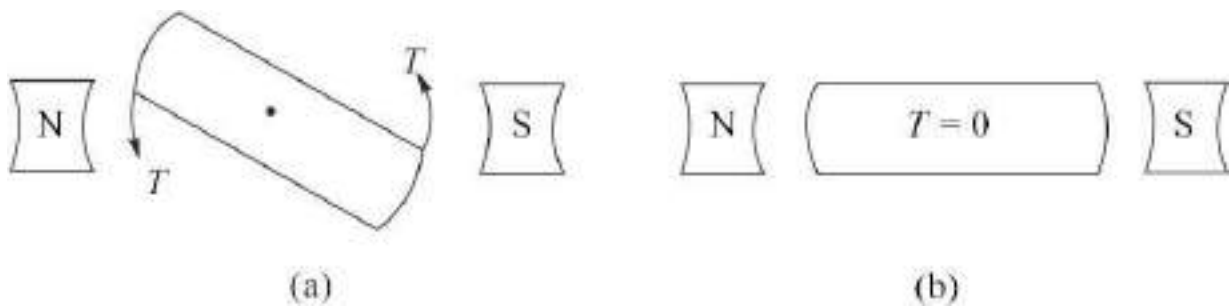

Figure: Reluctance torque developed on a magnetic material placed in a magnetic field

On the same lines, a reluctance motor is pulled into synchronous speed due to the intentionally created variation of air-gap reluctance in the Rotor placed in the stator Magnetic field. For starting torque, the stator of such motors consists of an Auxiliary winding, in addition to the main winding, just as in single phase Induction Motors. The rotor is a modified squirrel-cage rotor, with bars on the rotor slots and some of the rotor teeth removed to create a variation in air-gap reluctance. Variation of air-gap and hence variation in reluctance to flux path between the stator and rotor is produced by shaping the rotor laminations. Two different types of rotor laminations are shown in the figure below.

The motor starts as a single phase induction motor. The starting winding gets disconnected at a speed of about 75 percent of the synchronous speed, with the help of a centrifugal switch or over-current relay. From then onwards, the reluctance-torque developed pulls the rotor to synchronous speed.

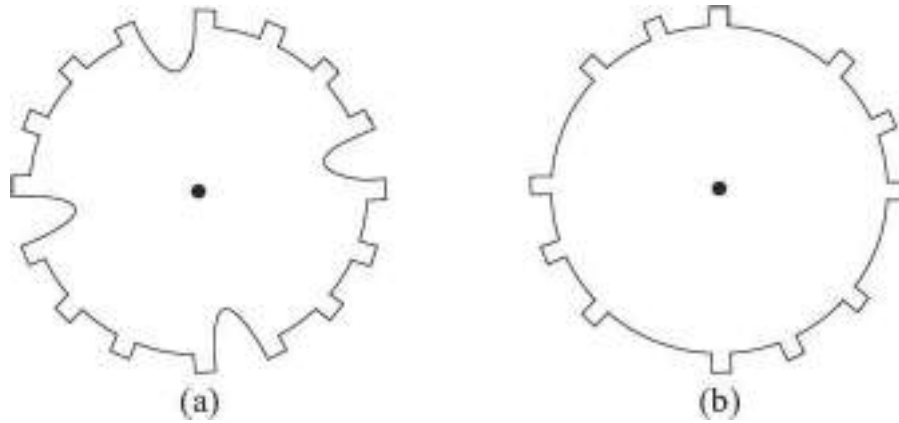

Figure: Different types of rotor laminations of reluctance motor

The direction of rotation of such motors can be reversed in the same manner as a single-phase induction motor by interchanging the auxiliary winding terminals. Typical Torque Speed characteristic of a reluctance motor is shown in the figure below.

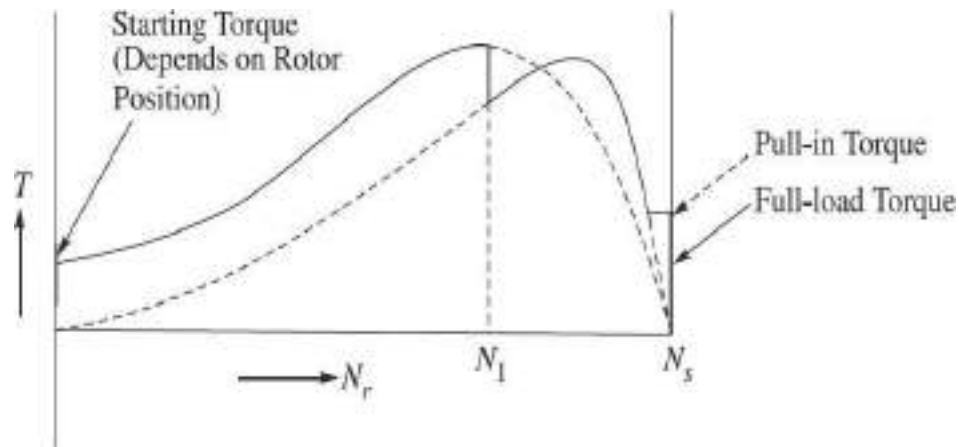

Figure: Torque-speed Characteristic of a Reluctance Motor

Hysteresis Motor:

A hysteresis motor is a single-phase Synchronous Motor without any projected poles and without DC excitation. Such motors start by virtue of the hysteresis losses induced in the hardened steel rotor by the rotating magnetic field produced by the stator windings and operate at synchronous speed due to the retentivity of the rotor core material.

The rotor of hysteresis motors are made with magnetic material of high hysteresis losses, i.e., whose hysteresis loop area is very large. A ring of cobalt or chrome steel is mounted on an **arbor** (shaft) made with non magnetic materials like aluminum as shown in the figure below.

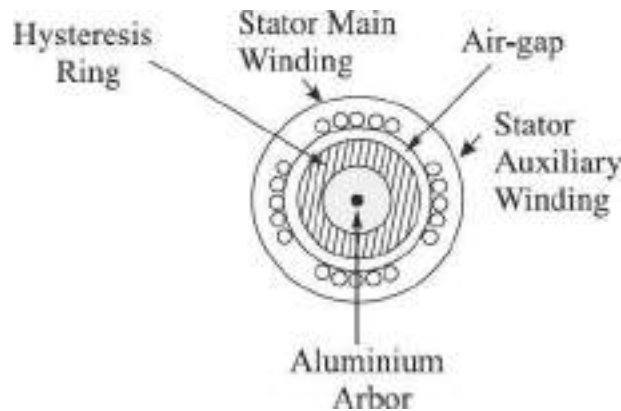

Figure: Cross-sectional view of a hysteresis motor

There are no windings or any copper bars on the rotor. The stator construction is either split-phase type or shaded-pole type. The motor starts rotating due to eddy-current and hysteresis torque developed by the rotor. Out of these two torques, eddy current torque gets reduced as the rotor picks up speed. This is because the induced eddy currents in the rotor get reduced as the relative velocity between the rotating stator magnetic field and the rotor gets reduced. Finally at synchronous speed there is no eddy current torque. But even at synchronous speed, the torque due to Hysteresis effect continues to exist due to residual magnetism in the rotor as explained further below.

Since some magnetism is left on the rotor poles even when the stator poles have moved in the clockwise direction as shown in the figure (b), the rotor continues to develop torque in the same direction. The magnetic strength of the rotor poles after the stator poles have moved forward will depend upon the residual magnetism (i.e., retentivity) of the magnetic material used. Higher the retentivity, of the material, the greater is the torque developed.

Hysteresis-torque depends only on the residual magnetism of the rotor-hysteresis ring material which is constant and is independent of the rotor speed. Because of the steady hysteresis-torque, such motors are very quiet in operation.

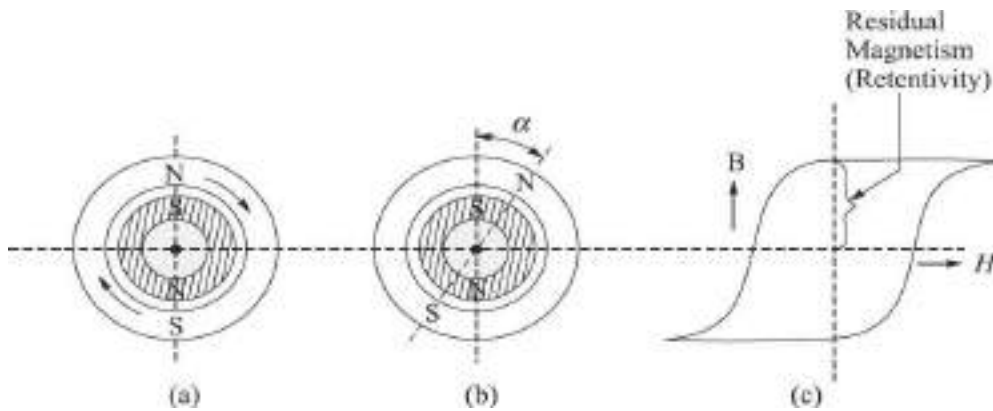

Figure: (a) Stator poles induce poles on the rotor (b) Torque developed on the rotor due to residual magnetism of the rotor (c) Hysteresis loop of the rotor material

Stepper Motors:

A **stepper motor** is a special type of synchronous motor which is designed to rotate a by specific angle for every electric pulse received from its control unit. A simple diagram of a stepper motor, with its associated control unit, control pulses and their sequence of application are shown in the figure below.

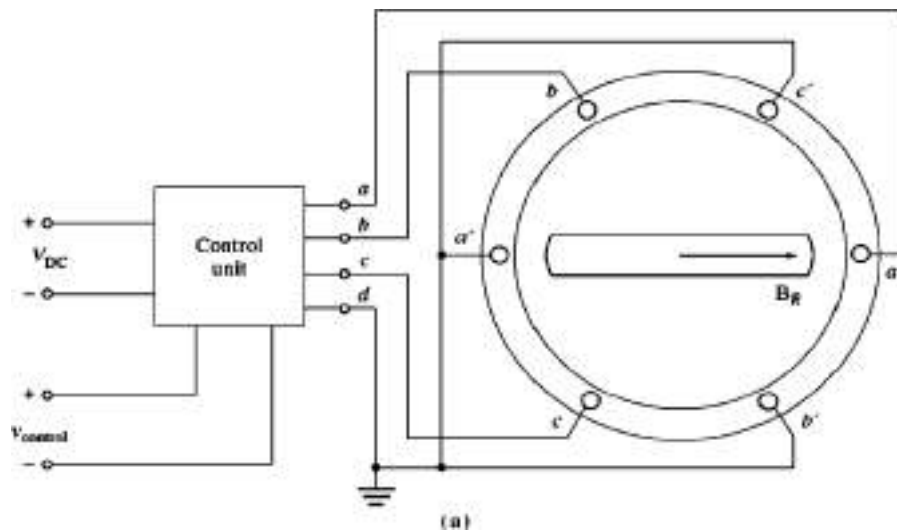
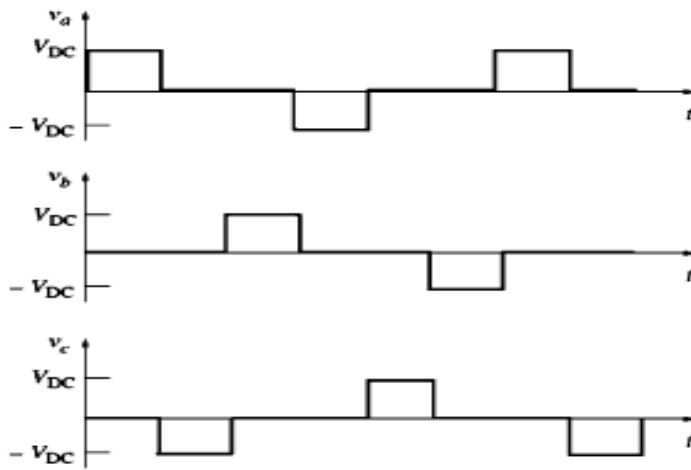

Figure: (a) A simple three-phase stepper motor and its associated control unit. The inputs to the control unit consist of a DC Power source and a control signal consisting of a train of pulses



(b)

Pulse number	Phase voltages, V		
	v_a	v_b	v_c
1	V_{DC}	0	0
2	0	0	$-V_{DC}$
3	0	V_{DC}	0
4	$-V_{DC}$	0	0
5	0	0	V_{DC}
6	0	$-V_{DC}$	0

(c)

(b) A sketch of the output voltage from the control unit as a series of control pulses are input (c) A table showing the output voltage from the control unit as a function of pulse number.

Operation of the stepper motor is clearly explained, with the help of the above figures and the subsequent figures (a) , (b) and (c) shown below.

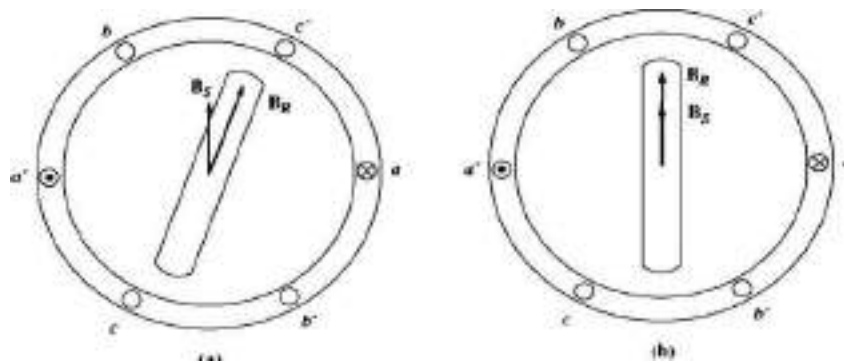
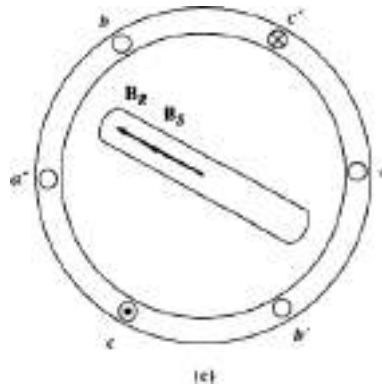

Figure (a) & (b) Operation of a stepper motor

Figure (a) above shows a 'two-pole' three-phase stator with a permanent magnet rotor, Stator magnetic field B_s just when a dc voltage V is applied to phase ' a ' of the stator with no voltages applied to the other phases ' b ' and ' c ' and the initial

position of the Rotor & its magnetic field. Immediately the interaction of B_R and B_S produces a counterclockwise torque on the rotor which causes it to line up with the stator magnetic field B_S , as shown in the figure (b) above.

Now when the voltage V to phase 'a' is turned off and a negative DC voltage $-V$ is applied to phase 'c' the new stator magnetic field rotates by 60° with respect to the previous magnetic field position, and the rotor of the motor follows it as shown in figure (c) below.



(c) Operation of a stepper motor contd...

By continuing this pattern, it is possible to construct a table showing the rotor position as a function of the voltage applied to the stator of the motor. If the voltage produced by the control unit changes with each input pulse in the order shown in the table below, then the stepper motor will advance by a step of 60° for one input pulse. (Corresponding to the minimum of Two poles & Three Phases)

Table: Rotor Position as a function of input pulse number and corresponding input voltage in a 'two pole' Stepper Motor

Input pulse number	Phase voltages			Rotor position
	a	b	c	
1	V	0	0	0°
2	0	0	$-V$	60°
3	0	V	0	120°
4	$-V$	0	0	180°
5	0	0	V	240°
6	0	$-V$	0	300°

*[(There are two basic types of stepper motors, differing only in rotor construction: **permanent-magnet type** and **reluctance type**. The permanent-magnet type of stepper motor has a permanent-magnet rotor, while the reluctance-type stepper motor has a ferromagnetic rotor which is not a permanent magnet. (Same as the type of Rotor used in Reluctance Motor studied earlier) In general, the permanent-magnet stepper motor can produce higher torque than the Reluctance - type since the permanent-magnet stepper motor has Torque from both the permanent magnet rotor magnetic field and reluctance effects.]*

*Reluctance type stepper motors are often built with a four-phase stator winding instead of the three-phase stator winding described above. A four-phase stator winding reduces the steps between pulses from **60** electrical degrees to 45 electrical degrees. As mentioned earlier, the torque in a reluctance motor varies as **sin 2δ**, so the reluctance torque between steps will be maximum for an angle of **45°**. Therefore, a given reluctance-type stepper motor can produce more torque with a four-phase stator winding than with a three-phase stator winding)*

(It is easy to build a stepper motor with a finer step size by increasing the number of poles on the motor. We know that the number of mechanical degrees corresponding to a given number of electrical degrees is given by the equation:

$$\Theta_m = (2/P) \Theta_e \quad (1)$$

*Since each step in the above Table corresponds to **60** electrical degrees, the number of mechanical degrees moved per step decreases with increasing numbers of poles. For example, if the stepper motor has **eight** poles, then the mechanical angle of the motor's shaft will change to **15°** per step)*

(The speed of a stepper motor can be related to the number of pulses into its control unit per unit time by using Equation (1). Equation (1) gives the mechanical angle of a stepper motor as a function of the electrical angle. If both sides of this equation are differentiated with respect to time, then we have a relationship between the electrical and mechanical rotational speeds of the motor:

$$\begin{aligned}\omega_m &= (2/P) \omega_e \\ n_m &= (2/P) n_e\end{aligned}$$

Since there are six input pulses per electrical revolution, the relationship between the speed of the motor in revolutions per minute and the number of pulses per minute becomes :

$$n_m = (1/3P) n_{pulses} \quad (2)$$

where n_{pulses} is the number of pulses per minute)

(Equation (2) can be generalized to apply to all stepper motors, regardless of the number of phases on their stator windings. In general, if a stator has N phases, it takes $2N$ pulses per electrical revolution in that motor. Therefore, the relationship between the speed of the motor in revolutions per minute and the number of pulses per minute becomes:

$$n_m = (1/NP) n_{pulses}]$$

Brushless DC Motors:

DC motors have a number of disadvantages due to Brushes and commutator, the main disadvantage being excessive sparking and brush wear. There was a dire need for a small, fast dc motor that is highly reliable and has low noise and long life. Such motors have been developed in the last 50 years by combining a small motor much like a permanent magnet Stepper motor with a Rotor position sensor and a solid-state electronic switching/driving circuit. These motors are called **Brush Less DC (BLDC) motors** because they run from a dc power source but do not have commutators and brushes. A sketch of a brushless DC motor is shown in the figure below.

The rotor is similar to that of a permanent magnet stepper motor, except that it is nonsalient. The stator can have three or more phases (there are four phases in the example shown)

The basic components of a brushless dc motor are:

1. A Permanent Magnet rotor
2. A Stator with a three, four, or more phase windings
3. A Rotor position sensor
4. An electronic circuit to control the phases of the rotor winding

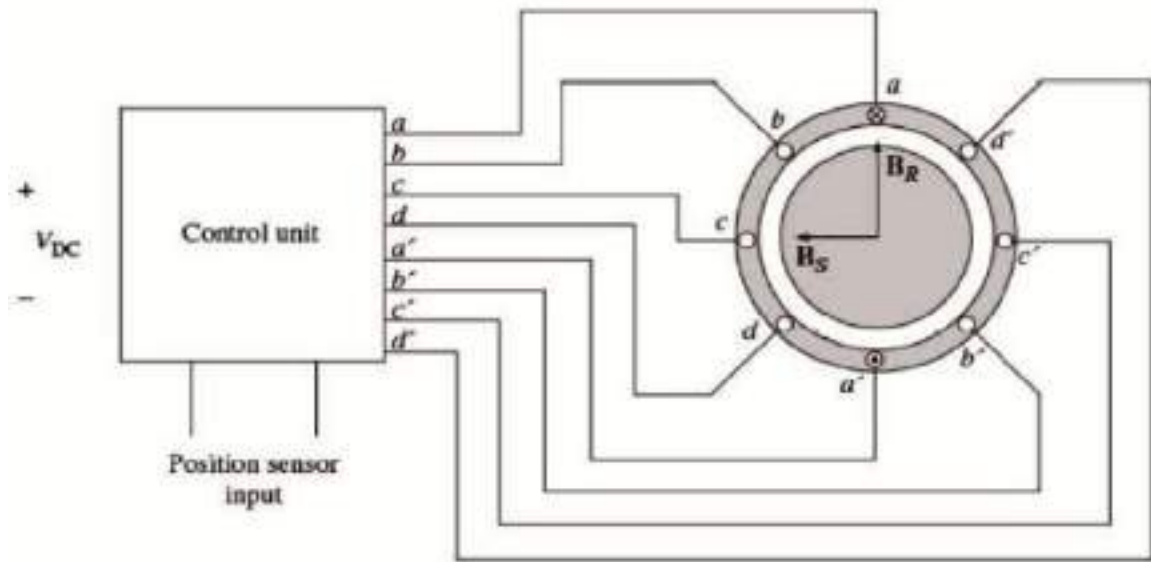

(a)

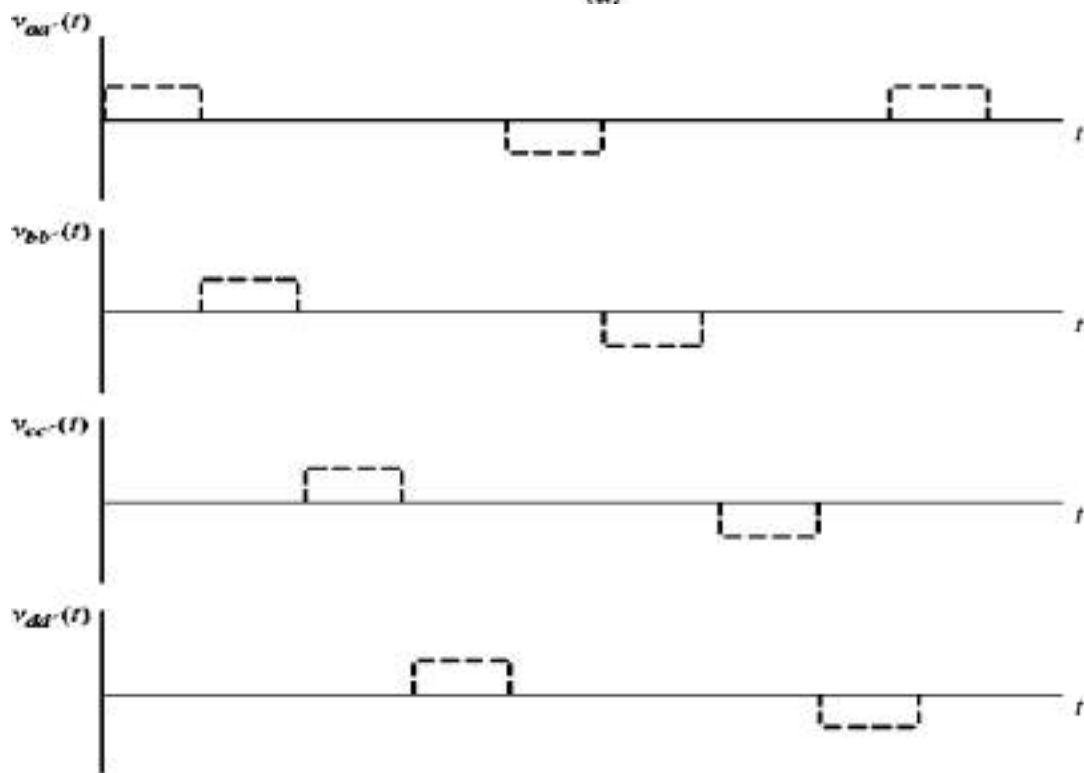

(b)

Figure : (a) A brushless dc motor and its associated control unit. The inputs to the control unit consist of a DC power source and a signal proportional to the current rotor position (b) the voltages applied to the stator coils.

A brushless dc motor functions by energizing one stator coil at a time with a constant DC voltage. When a coil is turned on, it produces a stator magnetic field \mathbf{B}_s , and a torque is produced on the rotor given by: $\boldsymbol{\tau} = k \mathbf{B}_R \times \mathbf{B}_s$ which tends to align the rotor with the stator magnetic field. At the time shown in figure (a), the stator magnetic field \mathbf{B}_s points to the left while the permanent magnet rotor magnetic field \mathbf{B}_R points upwards, producing a counterclockwise torque on the rotor. As a result the rotor will turn to the left. If coil 'a' remained energized all of the time, the rotor would turn until the two magnetic fields are aligned, and then it would stop, just like a stepper motor. **The key to the operation of a brushless dc motor is that it includes a 'position sensor'**, so that the control circuit will know when the rotor is almost aligned with the stator magnetic field. At that time coil 'a' will be turned off and coil 'b' will be turned on, causing the rotor to again rotate CCW. This process continues with the coils turned on in the order **a, b, c, d, -a, -b, -c, -d**, etc., so that the motor turns continuously in CCW direction. The electronics control circuit controls both the speed and direction of the motor. The advantage of this motor is that it runs precisely and silently from a DC power source, with full control over both the speed and the direction of rotation.

Important Questions:

1. (a) Explain the constructional features of a single phase Induction Motor
(b) Explain clearly why a single phase Induction Motor is not self starting
2. Explain the Double Field Revolving theory of Single phase Induction Motors
3. Explain with the help of neat diagrams the following methods of starting Induction Motors (i) Split Phase (ii) Capacitor Start (iii) Permanent Split-Capacitor (iv) Capacitor Start - Capacitor Run (v) Shaded Pole
4. Explaining clearly the steps involved, draw the Equivalent circuits of a Single Phase Induction Motor at stand still and in running condition.
5. Explain briefly the operation of AC Series Motors.
6. Write Short notes on the constructional features and operation of the following types of motors (i) Reluctance motors (ii) Hysteresis motors
7. With clear figures, sequence of operation and control waveforms explain the constructional features and operation of Stepper Motors.
8. Explain the constructional features and operation of Brushless DC Motors with clear figures, sequence of operation & control waveforms
