

**Department of Electrical & Electronics Engineering**

**Course File**

**POWER SEMICONDUCTOR DRIVES**  
(Course Code: **EE602PC**)

**III B.Tech II Semester**

**2023-24**

**Mr. M.Srinu**  
**Assist Professor**



**Department of Electrical & Electronics Engineering**
**POWER SEMICONDUCTOR DRIVES**
**Check List**

<b>S.No</b>	<b>Name of the Format</b>	<b>Page No.</b>
1	Syllabus	1
2	Timetable	3
3	Program Educational Objectives	4
4	Program Objectives	4
5	Course Objectives	5
6	Course Outcomes	5
7	Guidelines to study the course	6
8	Course Schedule	7
9	Course Plan	10
10	Unit Plan	14
11	Lesson Plan	19
12	Assignment Sheets	41
13	Tutorial Sheets	46
14	Evaluation Strategy	51
15	Assessment in relation to COB's and CO's	53
16	Mappings of CO's and PO's	53
17	Rubric for course	55
18	Mid-I and Mid-II question papers	56
19	Mid-I mark	60
20	Mid-II mark	61
21	Sample answer scripts and Assignments	62
22	Course materials like Notes, PPT's, etc.	63

# ANURAG ENGINEERING COLLEGE

(An Autonomous Institution)

III Year B.Tech. EEE - II Sem

L T/P/D C

3 1/-/ 4

## (EE602PC) POWER SEMICONDUCTOR DRIVES

### UNIT – I Control of DC motors by Single phase Converters

Introduction to Thyristor controlled Drives, Single Phase semi and Fully controlled converters connected to d.c separately excited and d.c series motors – continuous current operation – output voltage and current waveforms – Speed and Torque expressions – Speed – Torque Characteristics- Problems on Converter fed d.c motors.

### UNIT-II Control of DC motors by Three phase Converters

Three phase semi and fully controlled converters connected to d.c separately excited motors – output voltage and current waveforms – Speed and Torque expressions – Speed – Torque characteristics – Problems.

### UNIT – III Four Quadrant operations of DC Drives & Control of DC motors by Choppers

Introduction to Four quadrant operation – Motoring operations, Electric Braking – Plugging, Dynamic and Regenerative Braking operations. Four quadrant operation of D.C motors by dual converters

Single quadrant, Two –quadrant and four quadrant chopper fed dc separately excited and series excited motors – Continuous current operation – Output voltage and current wave forms – Speed torque expressions – speed torque characteristics – Problems on Chopper fed dc Motors.

### UNIT – IV Control of Induction Motor

From Stator Side: Variable voltage characteristics-Control of Induction Motor by Ac Voltage Controllers – Waveforms – speed torque characteristics. Variable frequency characteristics-V/F control of induction motor.

From Rotor side: Static rotor resistance control – Slip power recovery – Static Scherbius drive – Static Kramer Drive – their performance and speed torque characteristics – advantages applications – problems

**Department of Electrical & Electronics Engineering****UNIT – V Control of Synchronous Motors**

Separate control & self control of synchronous motors – Operation of self controlled synchronous motors by VSI and CSI cycloconverters. Load commutated CSI fed Synchronous Motor – Operation – Waveforms – speed torque characteristics – Advantages – Applications.

**Text Books:**

1. G K Dubey , “Fundamentals of Electric Drives”, CRC Press, 2002.
2. M.H.Rashid, “Power Electronic Circuits, Devices and applications”, Pearson Education India; 4<sup>rd</sup> edition, 2017.

**Reference Books:**

1. MD Singh and K B Khanchandani , “Power Electronics”, Tata – McGraw-Hill Publishing company,2017.
2. B.K.Bose, “Modern Power Electronics and AC Drives”, Prentice Hall, 2001.
3. Vedam Subramanyam, “Thyristor Control of Electric drives”, Tata McGraw Hill Publilcations, 2017.
4. S K Pillai, “A First course on Electrical Drives”, New Age International(P) Ltd. 3<sup>rd</sup> Editon, 2016.

**Department of Electrical & Electronics Engineering****Timetable****II B.Tech. I Semester – PSD**

<b>Day/Hour</b>	<b>9.40-10.30</b>	<b>10.30-11.20</b>	<b>11.20-12.00</b>	<b>12.00-12.55</b>	<b>12.55-1.50</b>	<b>1.50-2.45</b>	<b>2.45-3.50</b>
<b>Monday</b>							PSD
<b>Tuesday</b>		PSD					
<b>Wednesday</b>				PSD			
<b>Thursday</b>							
<b>Friday</b>					PSD		
<b>Saturday</b>		PSD					

## Department of Electrical & Electronics Engineering

### **Vision of the Institute**

To be a premier Institute in the country and region for the study of Engineering, Technology and Management by maintaining high academic standards which promotes the analytical thinking and independent judgment among the prime stakeholders, enabling them to function responsibly in the globalized society.

### **Mission of the Institute**

To be a world-class Institute, achieving excellence in teaching, research and consultancy in cutting-edge Technologies and be in the service of society in promoting continued education in Engineering, Technology and Management.

### **Quality Policy**

To ensure high standards in imparting professional education by providing world-class infrastructure, top-quality-faculty and decent work culture to sculpt the students into Socially Responsible Professionals through creative team-work, innovation and research

### **Vision of the Department**

To impart technical knowledge and skills required to succeed in life, career and help society to achieve self sufficiency.

### **Mission of the Department**

- To become an internationally leading department for higher learning.
- To build upon the culture and values of universal science and contemporary education.
- To be a center of research and education generating knowledge and technologies which lay groundwork in shaping the future in the fields of electrical and electronics engineering.
- To develop partnership with industrial, R&D and government agencies and actively participate in conferences, technical and community activities.

## Department of Electrical & Electronics Engineering

### Program Educational Objectives (B.Tech. – EEE)

#### Graduates will be able to

- PEO 1: Have a successful technical or professional career, including supportive and leadership roles on multidisciplinary teams.
- PEO 2: Acquire, use and develop skills as required for effective professional practices.
- PEO 3: Able to attain holistic education that is an essential prerequisite for being a responsible member of society.

### Program Outcomes (B.Tech. – EEE)

#### At the end of the Program, a graduate will have the ability to

- PO 1: Apply knowledge of mathematics, science, and engineering.
- PO 2: Design and conduct experiments, as well as to analyze and interpret data.
- PO 3: Design a system, component, or process to meet desired needs within realistic constraints such as economic, environmental, social, political, ethical, health and safety, manufacturability, and sustainability.
- PO 4: Function on multi-disciplinary teams.
- PO 5: Identify, formulates, and solves engineering problems.
- PO 6: Understanding of professional and ethical responsibility.
- PO 7: Communicate effectively.
- PO 8: Broad education necessary to understand the impact of engineering solutions in a global, economic, environmental, and societal context.
- PO 9: Recognition of the need for, and an ability to engage in life-long learning.
- PO 10: Knowledge of contemporary issues.
- PO 11: Utilize experimental, statistical and computational methods and tools necessary for engineering practice.
- PO 12: Demonstrate an ability to design electrical and electronic circuits, power electronics, power systems; electrical machines analyze and interpret data and also an ability to design digital and analog systems and programming them.

## Department of Electrical & Electronics Engineering

### COURSE OBJECTIVES

On completion of this Subject/Course the student shall be able to:

S.No	Objectives
1	This course deals with control of DC drives using single phase line commutated converters.
2	This course deals with control of DC drives using three phase line commutated converters
3	This course Provides knowledge about four quadrant operations of DC drives.
4	This course deals with control of induction motors drives.
5	This course deals with control of synchronous motors drives

### COURSE OUTCOMES

The expected outcomes of the Course/Subject are:

S.No	Outcomes
1.	Analyze DC motors speed control through single phase line commutated converters.
2.	Analyze DC motors speed control through three phase line commutated converters
3.	Analyze four quadrant operations of DC motors through choppers and dual converters.
4.	Analyze the operation of induction motor fed drives.
5.	Analyze the operation of synchronous motor fed drives.

Signature of faculty

Note: Please refer to Bloom's Taxonomy, to know the illustrative verbs that can be used to state the outcomes.



**Department of Electrical & Electronics Engineering**

**GUIDELINES TO STUDY THE COURSE / SUBJECT**

**Course Design and Delivery System (CDD):**

- The Course syllabus is written into number of learning objectives and outcomes.
- Every student will be given an assessment plan, criteria for assessment, scheme of evaluation and grading method.
- The Learning Process will be carried out through assessments of Knowledge, Skills and Attitude by various methods and the students will be given guidance to refer to the text books, reference books, journals, etc.

The faculty be able to –

- Understand the principles of Learning
- Understand the psychology of students
- Develop instructional objectives for a given topic
- Prepare course, unit and lesson plans
- Understand different methods of teaching and learning
- Use appropriate teaching and learning aids
- Plan and deliver lectures effectively
- Provide feedback to students using various methods of Assessments and tools of Evaluation
- Act as a guide, advisor, counselor, facilitator, motivator and not just as a teacher alone

Signature of HOD

Signature of faculty

Date:

Date:

**Department of Electrical & Electronics Engineering**
**COURSE SCHEDULE**

The Schedule for the whole Course / Subject is:

S. No.	Description	Duration (Date)		Total No. of Periods
		From	To	
1.	<b>UNIT-I: Control of DC motors by Single phase Converters</b> Introduction to Thyristor controlled Drives, Single Phase semi and Fully controlled converters connected to d.c separately excited and d.c series motors – continuous current operation – output voltage and current waveforms – Speed and Torque expressions – Speed – Torque Characteristics- Problems on Converter fed d.c motors	22.01.2024	04.02.2024	15
2.	<b>UNIT-II: Control of DC motors by Three phase Converters:</b> Three phase semi and fully controlled converters connected to d.c separately excited motors – output voltage and current waveforms – Speed and Torque expressions – Speed – Torque characteristics – Problems	06.02.2024	13.02.2024	12
3.	<b>UNIT-III: Four Quadrant operations of DC Drives &amp; Control of DC motors by Choppers:</b> Introduction to Four quadrant operation – Motoring operations, Electric Braking – Plugging, Dynamic and Regenerative Braking operations. Four quadrant operation of D.C motors by dual converters  Single quadrant, Two –quadrant and four quadrant chopper fed dc separately excited and series excited motors – Continuous current operation – Output voltage and current wave forms – Speed torque expressions – speed torque characteristics – Problems on Chopper fed dc Motors.	14.02.2024	7.3.2024	22
4.	<b>UNIT – IV Control of Induction Motor</b>  From Stator Side: Variable voltage characteristics- Control of Induction Motor by Ac Voltage Controllers – Waveforms – speed torque characteristics. Variable frequency characteristics-	08.03.2024	18.03.2024	21

**Department of Electrical & Electronics Engineering**

	<p>V/F control of induction motor.</p> <p>From Rotor side: Static rotor resistance control – Slip power recovery – Static Scherbius drive – Static Kramer Drive – their performance and speed torque characteristics – advantages applications – problems</p>			
5.	<p><b>UNIT – V Control of Synchronous Motors</b></p> <p>Separate control &amp; self control of synchronous motors – Operation of self controlled synchronous motors by VSI and CSI cycloconverters. Load commutated CSI fed Synchronous Motor – Operation – Waveforms – speed torque characteristics – Advantages – Applications</p>	19.03.2024	01.04.2024	25

Total No. of Instructional periods available for the course: 73 Hours

**Department of Electrical & Electronics Engineering**
**SCHEDULE OF INSTRUCTIONS - COURSE PLAN**

Unit No.	Lesson No.	Date	No. of Periods	Topics / Sub-Topics	Objectives & Outcomes Nos.	References (Textbook, Journal)
1	1	22-01-24	1	UNIT – I: Control of DC motors by Single phase Converters	1 1	“Fundamentals of Electric Drives”- G K Dubey
	2	23-01-24	1	Introduction to Drives	1 1	“Fundamentals of Electric Drives”- G K Dubey
	3	24-01-24	1	Introduction to DC motors	1 1	“Fundamentals of Electric Drives”- G K Dubey
	4	25-01-24	1	Introduction to DC motors	1 1	“Fundamentals of Electric Drives”- G K Dubey
	5	26-01-24	1	Introduction to power electronics	1 1	“Fundamentals of Electric Drives”- G K Dubey
	6	27-01-24	1	Introduction to Thyristor controlled Drives	1 1	“Fundamentals of Electric Drives”- G K Dubey
	7	28-01-24	1	Single Phase Semi controlled converters connected to d.c separately excited motors	1 1	“Fundamentals of Electric Drives”- G K Dubey
	8	29-01-24	1	Single Phase Semi controlled converters connected to d.c separately excited motors	1 1	“Fundamentals of Electric Drives”- G K Dubey
	9	30-01-24	1	Single Phase Fully controlled converters connected to d.c separately excited motors	1 1	“Fundamentals of Electric Drives”- G K Dubey
	10	31-01-24	1	Single Phase semi controlled converters connected to d.c series motors	1 1	“Fundamentals of Electric Drives”- G K Dubey
	11	01-02-24	1	Single Phase semi controlled converters connected to d.c series motors	1 1	“Fundamentals of Electric Drives”- G K Dubey
	12	02-02-24	1	Single Phase fully controlled converters connected to d.c series motors	1 1	“Fundamentals of Electric Drives”- G K Dubey
	13	03-02-24	1	Speed and Torque expressions – Speed – Torque characteristics	1 1	“Fundamentals of Electric Drives”- G K Dubey
	14	04-02-24	1	Problems on Converter fed d.c motors	1 1	“Fundamentals of Electric Drives”- G

### Department of Electrical & Electronics Engineering

					K Dubey	
	15	05-02-24	1	Problems on Converter fed d.c motors	1 1	
2	16	06-02-24	1	UNIT-II:Control of DC motors by Three phase Converters	2 2	
	17	07-02-24	1	Three phase Semi controlled converters connected to d.c separately excited motors	2 2	
	18	08-02-24	1	Three phase Semi controlled converters connected to d.c separately excited motors	2 2	
	19	09-02-24	1	Three phase Fully controlled converters connected to d.c separately excited motors	2 2	
	20	10-02-24	1	Three phase Fully controlled converters connected to d.c separately excited motors	2 2	
	21	11-02-24	1	Speed and Torque expressions – Speed – Torque characteristics	2 2	
	22	12-02-24	1	Problems on Converter fed three phase d.c motors	2 2	
	23	13-02-24	1	Problems on Converter fed three phase d.c motors	2 2	
	3	24	14-02-24	1	UNIT – III: Introduction to Four quadrant operation	3 3
		25	15-02-24	1	Motoring Operations, Electric Braking Operations	3 3
26		16-02-24	1	Plugging operation, Dynamic Braking operations	3 3	
27		17-02-24	1	Regenerative Braking operations	3 3	
28		18-02-24	1	Four quadrant operation of D.C motors by dual converters	3 3	
29		19-02-24	1	Four quadrant operation of D.C motors by dual converters	3 3	
30		20-02-24	1	Numerical problems	3 3	

### Department of Electrical & Electronics Engineering

					K Dubey
31	21-02-24	1	Numerical problems	3 3	"Fundamentals of Electric Drives"- G K Dubey
32	22-02-24	1	Numerical problems	3 3	"Fundamentals of Electric Drives"- G K Dubey
33	23-02-24	1	Numerical problems	3 3	"Fundamentals of Electric Drives"- G K Dubey
34	24-02-24	1	Numerical problems	3 3	"Fundamentals of Electric Drives"- G K Dubey
35	25-02-24	1	Revision	3 3	"Fundamentals of Electric Drives"- G K Dubey
36	26-02-24	1	Revision	3 3	"Fundamentals of Electric Drives"- G K Dubey
37	27-02-24	1	Single quadrant chopper fed dc separately excited motors	3 3	"Fundamentals of Electric Drives"- G K Dubey
38	28-02-24	1	Two –quadrant chopper fed dc separately excited motors	3 3	"Fundamentals of Electric Drives"- G K Dubey
39	29-02-24	1	Four quadrant chopper fed dc separately excited motors	3 3	"Fundamentals of Electric Drives"- G K Dubey
40	01-03-24	1	four quadrant chopper fed dc separately excited motors	3 3	"Fundamentals of Electric Drives"- G K Dubey
41	02-03-24	1	Single quadrant chopper fed dc series motors	3 3	"Fundamentals of Electric Drives"- G K Dubey
42	03-03-24	1	Two quadrant chopper fed dc series motors	3 3	"Fundamentals of Electric Drives"- G K Dubey
43	04-03-24	1	four quadrant chopper fed dc series motors	3 3	"Fundamentals of Electric Drives"- G K Dubey
44	05-03-24	1	UNIT-IV Control of Induction Motor from Stator Side:	3 3	"Fundamentals of Electric Drives"- G K Dubey
45	06-03-24	1	Variable voltage characteristics	3 3	"Fundamentals of Electric Drives"- G K Dubey
46	07-03-24	1	Control of Induction Motor by AC Voltage Controllers	3 3	"Fundamentals of Electric Drives"- G

### Department of Electrical & Electronics Engineering

						K Dubey
	47	08-03-24	1	UNIT – IV: Introduction	4 4	“Fundamentals of Electric Drives”- G K Dubey
	48	09-03-24	1	speed torque characteristics	4 4	“Fundamentals of Electric Drives”- G K Dubey
	49	10-03-24	1	Variable frequency characteristics- V/F control of induction motor.	4 4	“Fundamentals of Electric Drives”- G K Dubey
	50	11-03-24	1	From Rotor side: Static rotor resistance control	4 4	“Fundamentals of Electric Drives”- G K Dubey
	51	12-03-24	1	Slip power recovery	4 4	“Fundamentals of Electric Drives”- G K Dubey
	52	13-03-24	1	Numerical problems	4 4	“Fundamentals of Electric Drives”- G K Dubey
	53	14-03-24	1	Static Scherbius drive, their performance and speed torque characteristics	4 4	“Fundamentals of Electric Drives”- G K Dubey
	54	15-03-24	1	Static Kramer drive, their performance and speed torque characteristics	4 4	“Fundamentals of Electric Drives”- G K Dubey
	55	16-03-24	1	advantages and applications of IM drives	4 4	“Fundamentals of Electric Drives”- G K Dubey
	56	17-03-24	1	Numerical problems	4 4	“Fundamentals of Electric Drives”- G K Dubey
4	57	18-03-24	1	Numerical problems	4 4	“Fundamentals of Electric Drives”- G K Dubey
	58	19-03-24	1	UNIT – V: Control of Synchronous Motors	5 5	“Fundamentals of Electric Drives”- G K Dubey
5	59	20-03-24	1	Separate control of synchronous motors	5 5	“Fundamentals of Electric Drives”- G K Dubey
	60	21-03-24	1	Numerical problems	5 5	“Fundamentals of Electric Drives”- G K Dubey
	61	22-03-24	1	self control of synchronous motors	5 5	“Fundamentals of Electric Drives”- G K Dubey
	62	23-03-24	1	Operation of self controlled synchronous motors by VSI	5 5	“Fundamentals of Electric Drives”- G

### Department of Electrical & Electronics Engineering

			cycloconverters		K Dubey
63	24-03-24	1	Operation of self controlled synchronous motors by CSI cycloconverters	5 5	“Fundamentals of Electric Drives”- G K Dubey
64	25-03-24	1	Numerical problems	5 5	“Fundamentals of Electric Drives”- G K Dubey
65	26-03-24	1	Load commutated CSI fed Synchronous Motor – Operation	5 5	“Fundamentals of Electric Drives”- G K Dubey
66	27-03-24	1	Load commutated CSI fed Synchronous Motor – Waveforms, speed torque characteristics	5 5	“Fundamentals of Electric Drives”- G K Dubey
67	28-03-24	1	Numerical problems	5 5	“Fundamentals of Electric Drives”- G K Dubey
68	29-03-24	1	Numerical problems	5 5	“Fundamentals of Electric Drives”- G K Dubey
69	30-03-24	1	Advantages – Applications of Control of Synchronous Motors	5 5	“Fundamentals of Electric Drives”- G K Dubey
70	31-03-24	1	Revision	5 5	“Fundamentals of Electric Drives”- G K Dubey
71	01-04-24	1	Numerical problems	5 5	“Fundamentals of Electric Drives”- G K Dubey

Signature of HOD

Signature of faculty

Date:

Date:

Note:

1. Ensure that all topics specified in the course are mentioned.
2. Additional topics covered, if any, may also be specified in bold.
3. Mention the corresponding course objective and outcome numbers against each topic.



**Department of Electrical & Electronics Engineering**  
**LESSON PLAN (U-I)**

Unit No.	Lesson No.	Date	No. of Periods	Topics / Sub-Topics
	1	22-01-24	MON	UNIT – I: Control of DC motors by Single phase Converters
	2	23-01-24	TUE	Introduction to Drives
	3	24-01-24	WED	Introduction to DC motors
	4	25-01-24	THU	Introduction to DC motors
	5	26-01-24	SAT	Introduction to power electronics
	6	27-01-24	MON	Introduction to Thyristor controlled Drives
	7	28-01-24	TUE	Single Phase Semi controlled converters connected to d.c separately excited motors
	8	29-01-24	WED	Single Phase Semi controlled converters connected to d.c separately excited motors
	9	30-01-24	THU	Single Phase Fully controlled converters connected to d.c separately excited motors
	10	31-01-24	FRI	Single Phase semi controlled converters connected to d.c series motors
	11	01-02-24	MON	Single Phase semi controlled converters connected to d.c series motors
	12	02-02-24	TUE	Single Phase fully controlled converters connected to d.c series motors
	13	03-02-24	WED	Speed and Torque expressions – Speed – Torque characteristics
	14	04-02-24	THU	Problems on Converter fed d.c motors
	15	05-02-24	FRI	Problems on Converter fed d.c motors
	16	06-02-24	MON	UNIT-II:Control of DC motors by Three phase Converters
	17	07-02-24	TUE	Three phase Semi controlled converters connected to d.c separately excited motors
	18	08-02-24	WED	Three phase Semi controlled converters connected to d.c separately excited motors
	19	09-02-24	THU	Three phase Fully controlled converters connected to d.c separately excited motors
	20	10-02-24	FRI	Three phase Fully controlled converters connected to d.c separately excited motors
	21	11-02-24	MON	Speed and Torque expressions – Speed – Torque characteristics
	22	12-02-24	TUE	Problems on Converter fed three phase d.c motors
	23	13-02-24	FRI	Problems on Converter fed three phase d.c motors
	24	14-02-24	MON	UNIT – III: Introduction to Four quadrant operation
	25	15-02-24	TUE	Motoring Operations, Electric Braking Operations
	26	16-02-24	WED	Plugging operation, Dynamic Braking operations
	27	17-02-24	THU	Regenerative Braking operations
	28	18-02-24	FRI	Four quadrant operation of D.C motors by dual converters
	29	19-02-24	MON	Four quadrant operation of D.C motors by dual converters
	30	20-02-24	TUE	Numerical problems
	31	21-02-24	WED	Numerical problems
	32	22-02-24	MON	Numerical problems
	33	23-02-24	TUE	Numerical problems

### Department of Electrical & Electronics Engineering

34	24-02-24	WED	Numerical problems
35	25-02-24	THU	Revision
36	26-02-24	<b>SAT</b>	Revision
37	27-02-24	THU	Single quadrant chopper fed dc separately excited motors
38	28-02-24	FRI	Two –quadrant chopper fed dc separately excited motors
39	29-02-24	SAT	Four quadrant chopper fed dc separately excited motors
40	01-03-24	TUE	four quadrant chopper fed dc separately excited motors
41	02-03-24	WED	Single quadrant chopper fed dc series motors
42	03-03-24	THU	Two quadrant chopper fed dc series motors
43	04-03-24	MON	four quadrant chopper fed dc series motors
44	05-03-24	TUE	Control of Induction Motor from Stator Side:
45	06-03-24	WED	Variable voltage characteristics
46	07-03-24	THU	Control of Induction Motor by AC Voltage Controllers
47	08-03-24	<b>SAT</b>	UNIT – IV: Introduction
48	09-03-24	MON	speed torque characteristics
49	10-03-24	WED	Variable frequency characteristics-V/F control of induction motor.
50	11-03-24	MON	From Rotor side: Static rotor resistance control
51	12-03-24	TUE	Slip power recovery
52	13-03-24	THU	Numerical problems
53	14-03-24	FRI	Static Scherbius drive, their performance and speed torque characteristics
54	15-03-24	<b>SAT</b>	Static Kramer drive, their performance and speed torque characteristics
55	16-03-24	MON	advantages and applications of IM drives
56	17-03-24	TUE	advantages and applications of IM drives
57	18-03-24	WED	Numerical problems
58	19-03-24	THU	UNIT – V: Control of Synchronous Motors
59	20-03-24	FRI	Separate control of synchronous motors
60	21-03-24	<b>SAT</b>	Numerical problems
61	22-03-24	MON	self control of synchronous motors
62	23-03-24	TUE	Operation of self controlled synchronous motors by VSI cycloconverters
63	24-03-24	WED	Operation of self controlled synchronous motors by CSI cycloconverters
64	25-03-24	THU	Numerical problems
65	26-03-24	FRI	Load commutated CSI fed Synchronous Motor – Operation
66	27-03-24	MON	Load commutated CSI fed Synchronous Motor – Waveforms, speed torque characteristics
67	28-03-24	TUE	Numerical problems
68	29-03-24	WED	Numerical problems
69	30-03-24	THU	Advantages – Applications of Control of Synchronous Motors
70	31-03-24	FRI	Revision
71	01-04-24	SAT	Numerical problems

Signature of HOD

Signature of faculty

Date:

Date:

**Department of Electrical & Electronics Engineering**
**ASSIGNMENT – 1**

This Assignment corresponds to Unit No. 1

Question No.	Question	Objective No.	Outcome No.
1	<p>Two independent single-phase semi-converters are supplying the armature and field circuits of the separately excited DC motor for controlling its speed. The firing angle of the converter, supplying the field, adjusted such that maximum field current flows. The machine parameters are: armature resistance of <math>0.25\Omega</math>, field circuit resistance of <math>147\Omega</math>, motor voltage constant <math>K_f = 0.7032 \text{ V/A-rad/sec}</math>. The load torque is <math>45 \text{ N-m}</math> at <math>1000 \text{ rpm}</math>. The converters are fed from a <math>208 \text{ V}</math>, <math>50 \text{ Hz}</math> AC supply. The friction and windage losses are neglected. The inductance of the field and armature circuits are sufficient enough to make the armature and field currents continuous and ripple free.</p> <p>Determine</p> <ol style="list-style-type: none"> <li>The field current</li> <li>The delay angle of the armature converter</li> <li>Input power factor of the armature circuit converter:</li> </ol>	1	1
2	<p>A <math>220\text{V}</math>, <math>1000\text{rpm}</math>, <math>60 \text{ A}</math> separately excited de motor has an armature resistance of <math>0.1\Omega</math>. It is fed from a single - phase full converter with an ac source voltage of <math>230\text{V}</math>, <math>50 \text{ Hz}</math>. Assuming continuous conduction, compute</p> <ol style="list-style-type: none"> <li>Firing angle for rated motor torque at <math>600 \text{ rpm}</math></li> <li>Firing angle for rated motor torque at <math>(-500 \text{ rpm})</math></li> <li>Motor speed for <math>\alpha = 150^\circ</math> and half rated torque.</li> </ol>	1	1

Signature of HOD

Signature of faculty

Date:

Date:

**Department of Electrical & Electronics Engineering**
**ASSIGNMENT – 2**

This Assignment corresponds to Unit No. 2

Question No.	Question	Objective No.	Outcome No.
1	<p>The speed of a 125hp, 600V, 1800 rpm, separately excited de motor is controlled by a three phase full converter. The converter is operated from a 30, 480V, 60Hz supply. The rated armature current of the motor is 165A. The motor parameters are <math>R_a = 0.0874 \Omega</math>, <math>L_a = 6.5\text{mH}</math> and <math>K_\phi = 0.33\text{V/rpm}</math>. The converter and ac supply are considered to be ideal. Compute</p> <p>i) No - load speeds at firing angles <math>\alpha = 0^\circ</math> and <math>\alpha = 30^\circ</math>. Assume that at no - load, the armature current is 10% of the rated current and is continuous,</p> <p>Find the firing angle to obtain the rated speed of 1800 rpm at rated motor current.</p>	2	2
2	<p>A 220 V, 1500 rpm, 50A separately excited motor with armature resistance of 0.58 is fed from a three phase fully controlled rectifier. Available ac source has a line voltage of 440 V, 50Hz. A star - delta connected transformer is used to feed the armature so that motor terminal voltage equals rated voltage when converter firing angle is zero. Calculate transformer turns ratio. Determine the value of firing angle when</p> <p>i) motor is running at 1200 rpm and rated torque,          ii) when motor is running at (- 800) rpm and twice the rated torque. Assume continuous conduction.</p>	2	2

Signature of HOD

Signature of faculty

Date:

Date:

**Department of Electrical & Electronics Engineering**
**ASSIGNMENT – 3**

This Assignment corresponds to Unit No. 3

Question No.	Question	Objective No.	Outcome No.
1	WA 220 V, 970 rpm, 100 A DC separately excited motor has an armature resistance of $0.05\Omega$ . It is braked by plugging from an initial speed of 1000 rpm. Calculate . a) Resistance to be placed in armature circuit to limit braking current to twice the full load value, b) Braking torque and c) Torque when the speed has fallen to zero what is the force exerted on a differential current element in a given magnetic field.	3	3
2	Explain static Kramer drive	3	3

Signature of HOD

Signature of faculty

Date:

Date:

**Department of Electrical & Electronics Engineering****ASSIGNMENT – 4**

This Assignment corresponds to Unit No. 4

Question No.	Question	Objective No.	Outcome No.
1	Discuss Displacement current and Displacement current density Draw a block schematic diagram for automatic speed control of three phase induction motor using solid state AC voltage controller and stator side..	4	4
2	Draw and explain close the loop operational static kramar controlled drive.	4	4

Signature of HOD

Signature of faculty

Date:

Date:

**Department of Electrical & Electronics Engineering****ASSIGNMENT – 5**

This Assignment corresponds to Unit No. 5

Question No.	Question	Objective No.	Outcome No.
1	Draw the block diagram of a closed loop synchronous motor drive Fed from VSI and explain.	5	5
2	Describe separate control mode and self control mode of operation of a synchronous motor drive in detail and comparison Them.	5	5

Signature of HOD

Signature of faculty

Date:

Date:

**Department of Electrical & Electronics Engineering**

**TUTORIAL – 1**

This tutorial corresponds to Unit No. 1 (Objective Nos.: 1, Outcome Nos.: 1)

1. An unsaturated de shunt motor runs at its rated speed when rated voltage is applied to it. If the supply voltage to the motor is reduced by 25% the speed of the motor

- a) increases by 25%
- b) remains the same
- c) decrease by 25%
- d) decrease only slightly by an amount less than 25%

2. Speed control of de shunt motors by means of field weakening is suitable for

- a) constant power operation
- b) constant torque operation
- c) constant torque and constant power operation
- d) variable torque and variable power operation

3. In an unsaturated de series motor.

- a) torque is proportional to armature current
- b) torque is proportional to field current
- c) torque is proportional to the square root of the armature current
- d) torque is proportional to the square of the armature current

Signature of HOD

Signature of faculty

Date:

Date:



**Department of Electrical & Electronics Engineering**

**TUTORIAL – 2**

This tutorial corresponds to Unit No. 2 (Objective Nos.: 2, Outcome Nos.: 2)

7. For controlling the speed of the motor of 150 hp rating, the following types of converters are normally used.

- a) single phase full converters      c) three phase full converters
- b) single phase dual converters      d) three phase dual converters

8. In a separately excited dc motor, constant horsepower control of speed is achieved by variation.

variation and constant torque control by

- a) armature current, armature voltage      b) field current, armature voltage
- c) field voltage, field current      d) armature voltage, field current

9. In the armature control method, if the applied armature voltage  $V$  is decreased by a large amount, then the motor

- a) speed gets reduced      b) gets overloaded
- c) is constrained to work as a generator      d) quickly comes to a standstill

Signature of HOD

Signature of faculty

Date:

Date:

**Department of Electrical & Electronics Engineering**

**TUTORIAL SHEET – 3**

5. A free wheeling diode in a phase controlled converter.

- a) causes smoothening of load current
- b) causes poor voltage regulation
- c) enables inverter operation
- d) none of these

6. A half controlled converter

- a) has an improved power factor
- b) is capable of inversion also
- c) has poor voltage regulation
- d) all of these

7. For controlling the speed of de motor of 150 hp rating, the following types of converters are normally used.

- a) single phase full converters
- b) single phase dual converters
- c) three phase full converters
- d) three phase dual converters

Signature of HOD

Signature of faculty

Date:

Date:

**Department of Electrical & Electronics Engineering**

**TUTORIAL – 4**

This tutorial corresponds to Unit No. 4 (Objective Nos.: 3, Outcome Nos.: 3)

1. At zero in an induction motor

- a) Motor runs as a generator      b) Motor does not run
- c) The motor runs at synchronous speed      d) Slip produced is zero

2. In an induction motor, rotor slots are usually not quite parallel to the shaft but are given a slight skew

- a) To reduce the magnetic hum      b) To reduce the locking tendency of the rotor
- c) Both (a) and (b) above      d) To increase the speed of the motor

3. The field of an induction motor rotor rotates relative to the stator at

- a) Rotor speed      b) Synchronous speed
- c) Slip speed      d) Very low speed

Signature of HOD

Signature of faculty

Date:

Date:

**Department of Electrical & Electronics Engineering**

**TUTORIAL SHEET – 5**

This tutorial corresponds to Unit No. 5 (Objective Nos.: 5, Outcome Nos.: 5)

Q1. Slip-rings in a synchronous motor carry ?

- a) direct current
- b) alternating current
- c) no current
- d) all of the above

Q2. Asynchronous motor which works on a leading power factor and does not drive a mechanical load is called as ?

- a) static condenser
- b) condenser
- c) synchronous condenser
- d) none of the above

Q3. The coupling angle or load angle of synchronous motor is defined as the angle between the ?

- a) rotor and stator teeth
- b) rotor and the stator poles of opposite polarity
- c) rotor and the stator poles of the same polarity
- d) none of the above

Signature of HOD

Signature of faculty

Date:

Date:

**Department of Electrical & Electronics Engineering**

**EVALUATION STRATEGY**

Target (s)

- a. Percentage of Pass : 95%

Assessment Method (s) (Maximum Marks for evaluation are defined in the Academic Regulations)

- a. Daily Attendance
- b. Assignments
- c. Online Quiz (or) Seminars
- d. Continuous Internal Assessment
- e. Semester / End Examination

List out any new topic(s) or any innovation you would like to introduce in teaching the subjects in this semester

Case Study of any one existing application

Signature of HOD

Signature of faculty

Date:

Date:

**Department of Electrical & Electronics Engineering****COURSE COMPLETION STATUS**

Actual Date of Completion &amp; Remarks if any

<b>Units</b>	<b>Remarks</b>	<b>Objective No. Achieved</b>	<b>Outcome No. Achieved</b>
Unit 1	completed on 04.02.2024	1	1
Unit 2	completed on 13.02.2024	2	2
Unit 3	completed on 07.03.2024	3	3
Unit 4	completed on 18.03.2024	4	4
Unit 5	completed on 01.04.2024	5	5

Signature of HOD

Signature of faculty

Date:

Date:

## Department of Electrical & Electronics Engineering

### Mappings

#### 1. Course Objectives-Course Outcomes Relationship Matrix

(Indicate the relationships by mark "X")

Course-Objectives \ Course-Outcomes	1	2	3	4	5
1	H		M		
2		H			
3			H		
4				H	
5					H

#### 2. Course Outcomes-Program Outcomes (POs) & PSOs Relationship Matrix

3.

CO'S \ PO'S	PO 1	PO 2	PO 3	PO 4	PO 5	PO 6	PO 7	PO 8	PO 9	PO 10	PO 11
CO 1	✓	✓	✓		✓				✓		✓
CO 2	✓	✓	✓	✓	✓						✓
CO 3	✓	✓	✓		✓				✓		✓
CO 4	✓	✓		✓	✓						✓
CO 5	✓	✓		✓	✓						✓

## Department of Electrical & Electronics Engineering

### Rubric for Evaluation

Performance Criteria	Unsatisfactory	Developing	Satisfactory	Exemplary
	1	2	3	4
<b><i>Research &amp; Gather Information</i></b>	Does not collect any information that relates to the topic	Collects very little information some relates to the topic	Collects some basic Information most relates to the topic	Collects a great deal of Information all relates to the topic
<b><i>Fulfill team role's duty</i></b>	Does not perform any duties of assigned team role.	Performs very little duties.	Performs nearly all duties.	Performs all duties of assigned team role.
<b><i>Share Equally</i></b>	Always relies on others to do the work.	Rarely does the assigned work - often needs reminding.	Usually does the assigned work - rarely needs reminding.	Always does the assigned work without having to be reminded
<b><i>Listen to other team mates</i></b>	Is always talking— never allows anyone else to speak.	Usually doing most of the talking-- rarely allows others to speak.	Listens, but sometimes talks too much.	Listens and speaks a fair amount.



**III B.TECH VI SEMESTER I MID EXAMINATIONS - MARCH 2024**

Branch : B.Tech. (EEE)

Subject : POWER SEMICONDUCTOR  
DRIVES,EE602PC

Max. Marks : 20M

Date : 19.03.2024 AN

Time : 90 Minutes

**PART - A**

ANSWER ALL THE QUESTIONS.

5 X 1M = 5M

Q.NO	Question	CO	BTL
1.	Define electric drive?	CO1	L1
2.	What is an electric drive. Mention the application of electric drives	CO1	L1
3.	Draw the speed - torque characteristics of separately excited dc motor?	CO2	L1
4.	Write down the average output voltage equation of three - phase full converter?	CO2	L1
5.	What are four quadrants of an electrical drives.	CO3	L2

**PART - B**

ANSWER ALL THE QUESTIONS.

3 X 5M = 15M

Q.NO	Question	CO	BTL
6.	Derive an expression related speed and torque of a single phase fully converter fed series motor drive operating in the continuous current mode operation	CO1	L2
<b>OR</b>			
7.	A single phase fully controlled thyristor bridge converter, operating from 230V, 50Hz mains, supplies the armature of a separately excited dc motor running at a speed of 1000 rpm. The motor has an armature resistance of 0.5 and a back emf constant of 0.1 V/rpm. Assuming continuous current operation for a firing angle of 30°, estimate the average armature current and the torque developed by the motor.	CO1	L3
8.	Derive an expression related speed and torque of a Three phase fully converter fed separately excited DC motor drive operating in the continuous current mode operation	CO2	L2
<b>OR</b>			
9.	A 220 V, 1500 rpm, 50A separately excited motor with armature resistance of 0.58 is fed from a three phase fully controlled rectifier. Available ac source has a line voltage of 440 V, 50Hz. A star - delta connected transformer is used to feed the armature so that motor terminal voltage equals rated voltage when converter firing angle is zero. Calculate transformer turns ratio. Determine the value of firing angle when i) motor is running at 1200 pm and rated torque, i) when motor is running at (- 800) rpm and twice the rated torque. Assume continuous conduction.	CO2	L3
10.	Describe the single phase 4 quadrant operation of DC drive using dual converter	CO3	L2

**OR**

11. . A 220 V, 970 rpm, 100 A DC separately excited motor has an armature resistance of 0.05. It is braked by plugging from an initial speed of 1000 rpm. Calculate .
- Resistance to be placed in armature circuit to limit braking current to twice the full load value,
  - Braking torque and
  - Torque when the speed has fallen to zero.

CO3

1.3



**III B.TECH VI SEMESTER II MID EXAMINATIONS - JUNE 2024**

Branch : B.Tech. (EEE)

Max. Marks : 20M

Date : 18-Jun-2024 Session : Afternoon

Time : 90 Min

Subject : POWER SEMICONDUCTOR DRIVES,EE602PC

**PART - A**

ANSWER ALL THE QUESTIONS

5 X 1M = 5M

Q.No	Question	CO	BTL
1.	What are the different types of control strategies in a DC chopper	CO3	L1
2.	Differentiate VSI and CSI.	CO4	L1
3.	Write the difference between cyclo converter and AC voltage controller?	CO4	L2
4.	What is meant by self-control of synchronous motor.	CO5	L2
5.	What is the basic concept of cycloconverters?	CO5	L1

**PART - B**

ANSWER ALL THE QUESTIONS

3 X 5M = 15M

Q.No	Question	CO	BTL
6.	Explain chopper control of series DC motor drive.	CO3	L2
<b>OR</b>			
7.	Describe the working of a single quadrant chopper fed DC series motor drive.	CO3	L2
8.	What is an AC voltage controller? explain with suitable diagrams the various types of solid state three phase AC voltage controllers which can be used for speed control of three phase induction motor from starter side.	CO4	L3
<b>OR</b>			
9.	Explain the closed loop control of VSI and CSI.	CO4	L2
10.	Describe separate controlled method of operation of a synchronous motor drive in detail.	CO5	L3
<b>OR</b>			
11.	Discuss the VSI method of speed control of synchronous motor describe the operation of the converter.	CO5	L2

## First Internal Examination Marks

Programme: **BTech**

Year: **III**

Course: **Theory**

A.Y: **2023-24**

Course: **Power semiconductor drives**

Section: **A**

Faculty Name: **M.Srinu**

S. No	Roll No	Objective Marks (5)	Subjective Marks (15)	Total Marks (20)
1	21C11A0201	2	7	09
2	21C11A0204	2	6	08
3	21C11A0205	3	8	11
4	21C11A0206	2	8	10
5	21C11A0207	4	10	14
6	21C11A0208	3	10	13
7	21C11A0209	4	14	18
8	21C11A0210	3	16	19
9	21C11A0211	5	15	20
10	21C11A0212	2	8	10
11	21C11A0213	3	8	11
12	21C11A0214	2	11	13
13	21C11A0215	4	11	15
14	22C15A0201	2	9	11
15	22C15A0202	3	13	16
16	22C15A0203	4	15	19
17	22C15A0204	3	14	17
18	22C15A0205	3	10	13
19	22C15A0206	4	15	19
20	22C15A0207	3	14	17
21	22C15A0208	2	9	11
22	22C15A0209	4	12	16
23	22C15A0210	3	15	18

No. of Absentees: **00**

Total Strength: **23**

Signature of Faculty

:

Signature of HoD

## Second Internal Examination Marks

Programme: **BTech**

Year: **III**

Course: **Theory**

A.Y: **2023-24**

Course: Power semiconductor drives

Section: A

Faculty Name: M.Srinu

S. No	Roll No	Objective Marks (5)	Subjective Marks (15)	Total Marks (20)
1	21C11A0201	2	5	07
2	21C11A0204	3	8	11
3	21C11A0205	2	5	07
4	21C11A0206	2	4	06
5	21C11A0207	3	7	10
6	21C11A0208	3	9	12
7	21C11A0209	3	9	12
8	21C11A0210	4	11	15
9	21C11A0211	4	15	19
10	21C11A0212	3	7	10
11	21C11A0213	3	9	12
12	21C11A0214	2	6	08
13	21C11A0215	2	11	13
14	22C15A0201	2	9	11
15	22C15A0202	3	11	14
16	22C15A0203	4	14	18
17	22C15A0204	3	10	13
18	22C15A0205	3	9	12
19	22C15A0206	4	14	18
20	22C15A0207	4	14	18
21	22C15A0208	2	7	09
22	22C15A0209	4	13	17
23	22C15A0210	4	12	16

No. of Absentees: 00

Total Strength: 23

Signature of Faculty

:

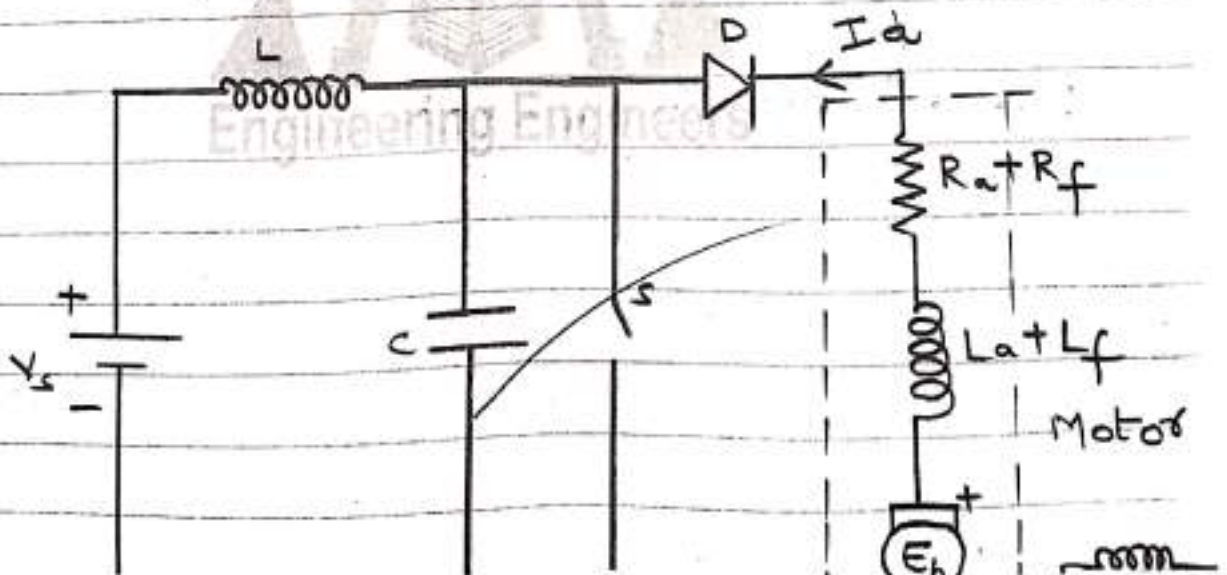
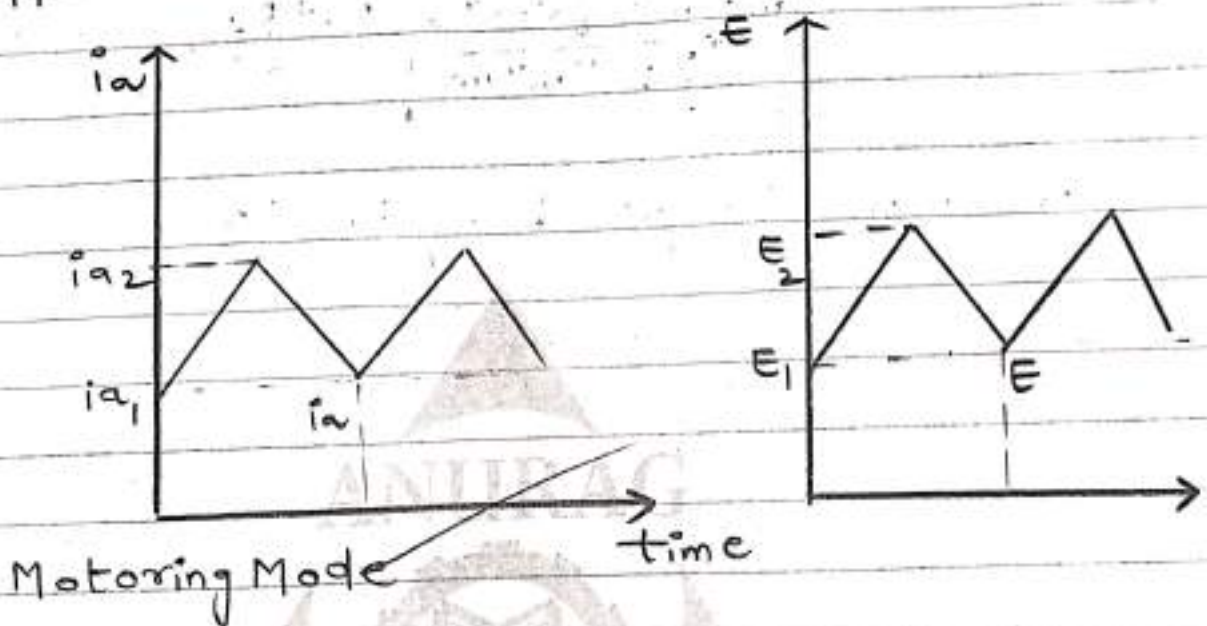
Signature of HoD

Program			YEAR	SEMESTER	MID EXAMINATION					
B.Tech. ✓	M.Tech.	M.B.A.	III	II	II					
HALL TICKET NO.			Regulation: R18	Branch or Specialization: EEE						
21C11A0211			Signature of Student: Md. Seema							
Course: Power semiconductor drives			Signature of invigilator with date: [Signature] 18/09/24							
Q.No. and Marks Awarded			Signature of the Evaluator: [Signature]							
1	2	3	4	5	6	7	8	9	10	11
1	1	0	1	1	5			5	5	
			Maximum Marks	20	Marks Obtained	19				

(Start Writing From Here)

## PART-B

a) chopper control of series DC Motor drive



In regenerative Mode motor works as generator mechanical energy is converted into electrical energy. i.e magnetic energy is stored in inductor and remaining dissipated energy is transferred into resistor and diode. The energy (or) voltage in the load is greater than the supply voltage ( $V_m > V_c$ ) when the chopper is ON.

$$E_b = V_a - I_a (R_a + R_f)$$

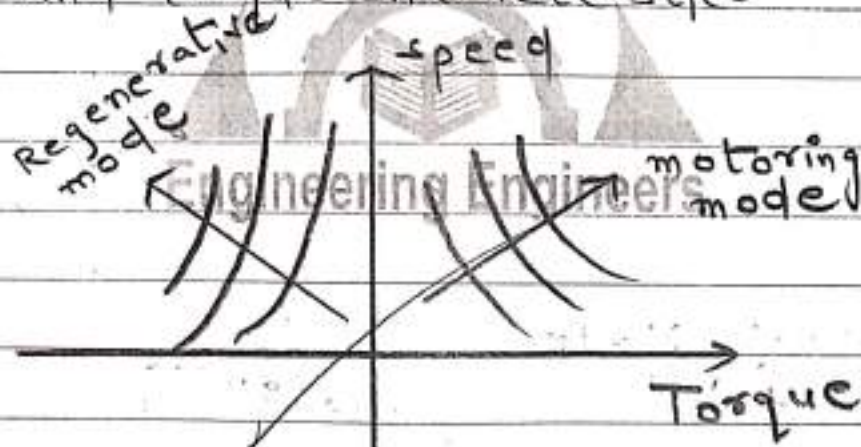
$$V_a = \delta V$$

$$E_b = \delta V - I_a (R_a + R_f)$$

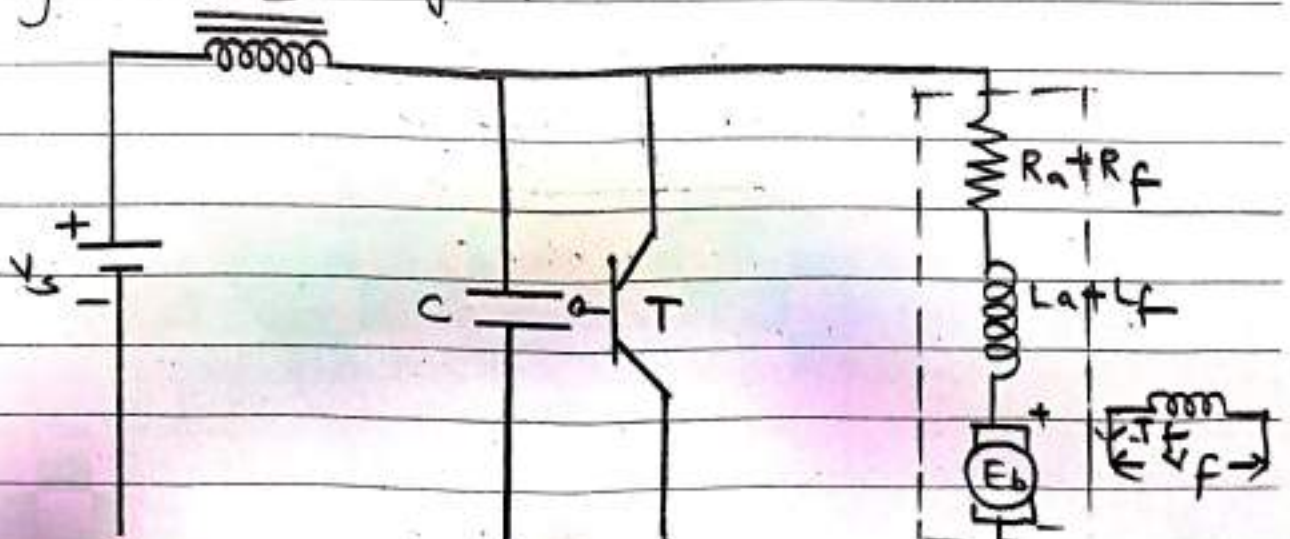
$$K_m \omega_m = \delta V - I_a (R_a + R_f)$$

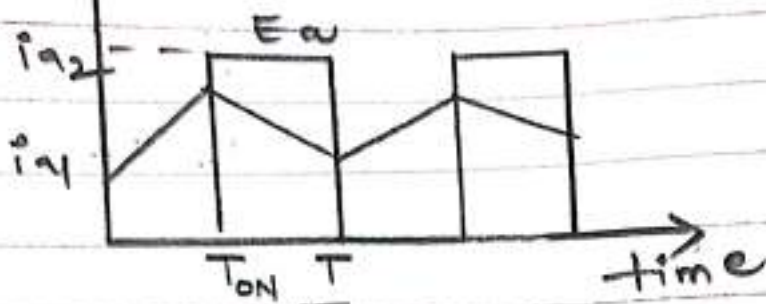
$$E_b = K_m \omega_m$$

speed and torque characteristics



Dynamic braking mode:





$$V_a = \frac{1}{T} \int_{T_{ON}}^T V_s dt$$

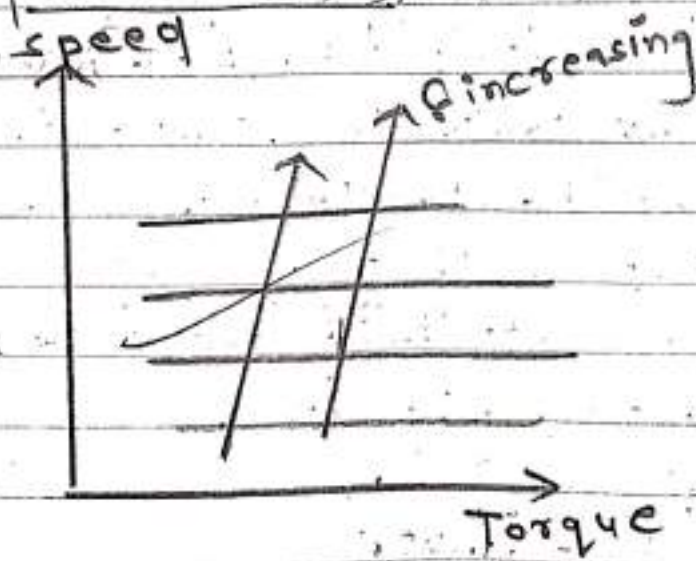
$$= \frac{V_s}{T} \int_{T_{ON}}^T 1 dt$$

$$= \frac{V_s}{T} [t]_{T_{ON}}^T$$

$$= \frac{V_s}{T} [T - T_{ON}]$$

$$= V_s \left[ \frac{T - T_{ON}}{T} \right]$$

$$V_a = V_s (1 - \delta)$$

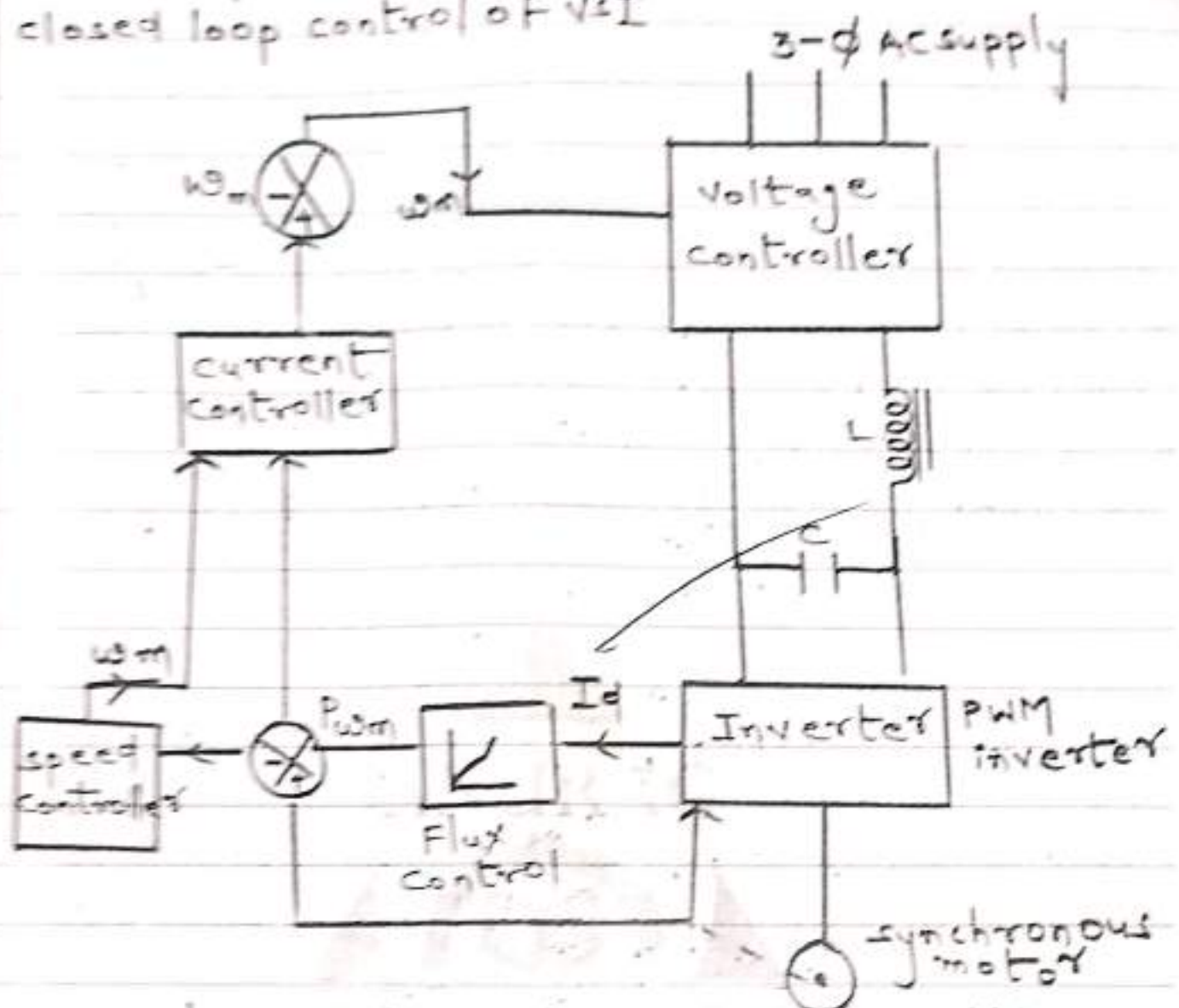


speed-torque characteristics



closed loop control of VSI and CSI

1) closed loop control of VSI

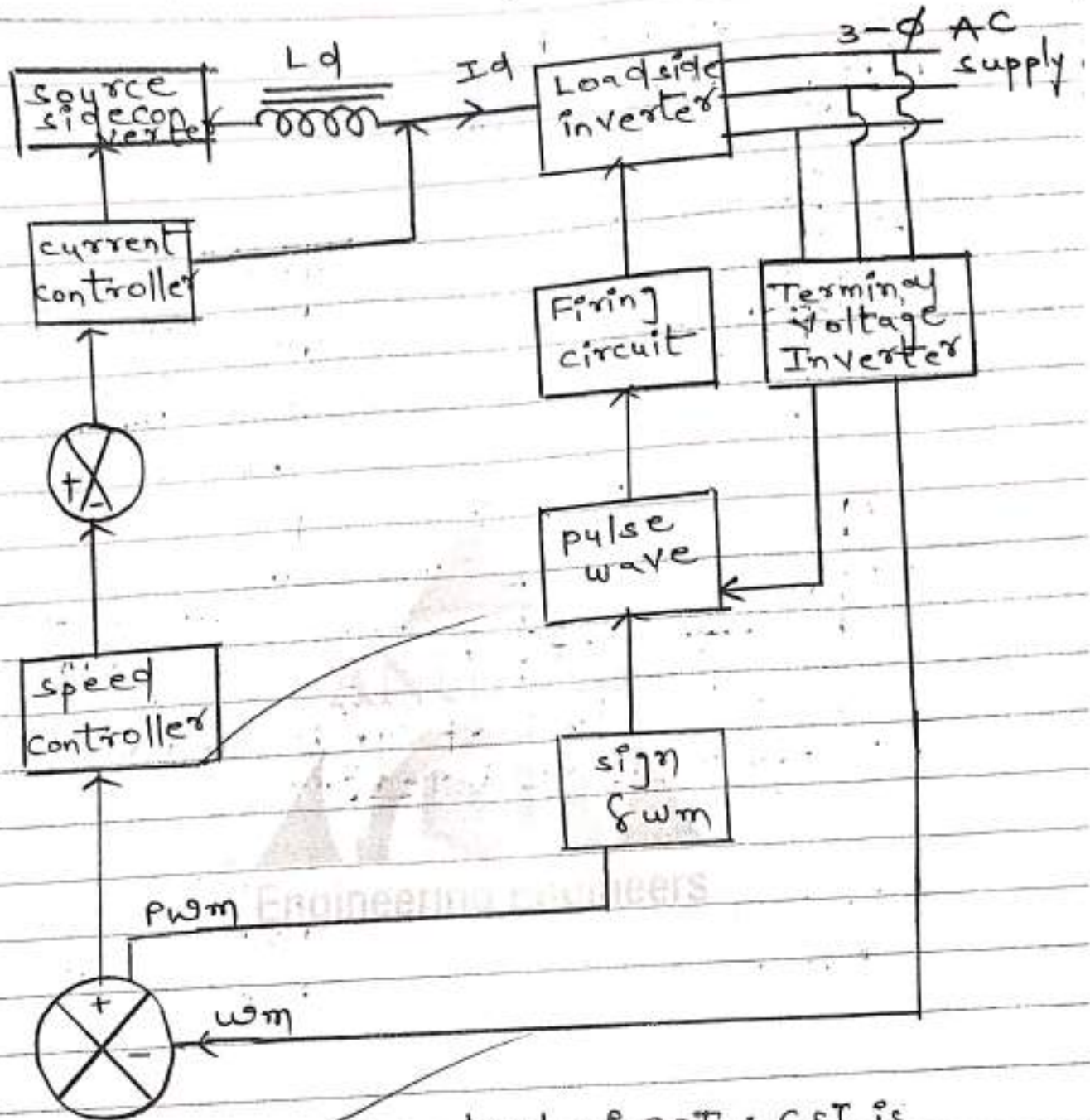


closed loop control of VSI is nothing but voltage source inverter. How speed can be controlled by using voltage controller. Inverter converts DC to AC. AC source is given flux controller. Flux controller is given to speed controller. speed will be controlled from that current will be produced. current limit controller is kept voltage can be controlled.

$$E_b = V_a - I_a R_a$$

$$E_b = K_m \omega_m$$

# closed loop control of CSI



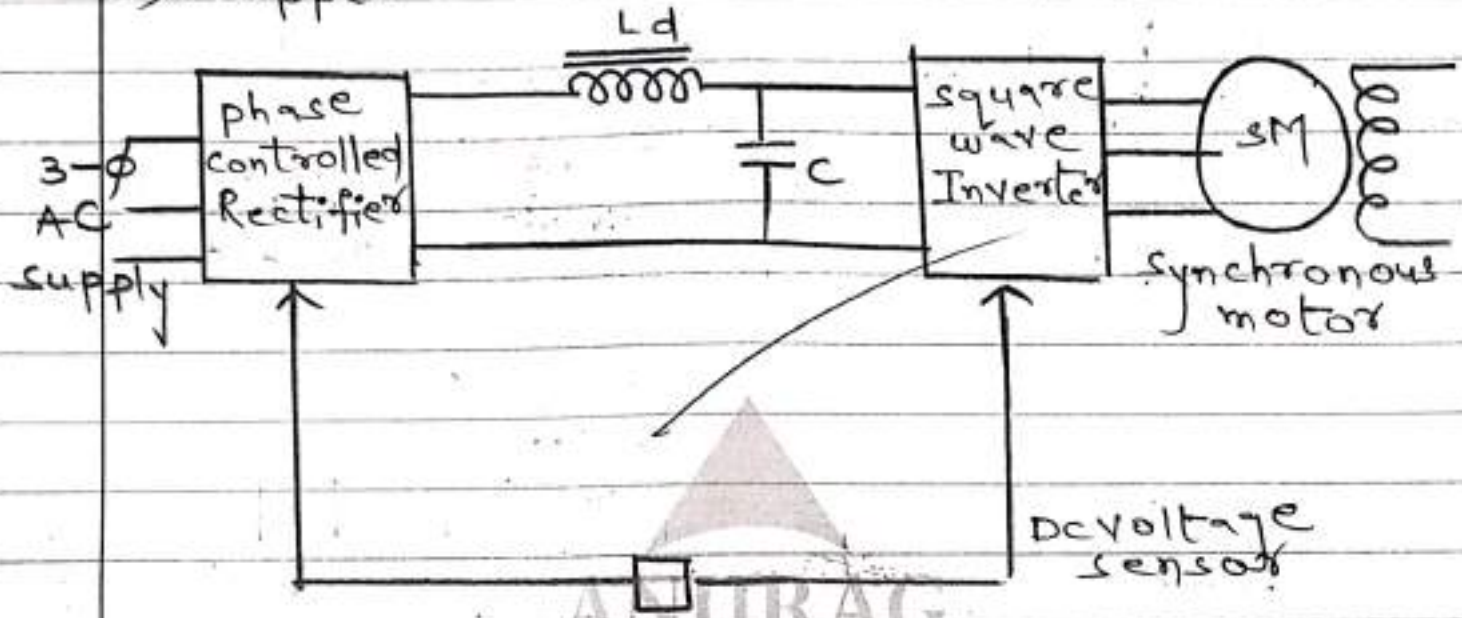
closed loop speed control of CSI = CSI is nothing but current source inverter it can be controlled by giving pulse to the load side and decreasing the speed and current. load voltage is greater than supply voltage ( $V_L > V_s$ ).

# VSI method of speed control of synchronous

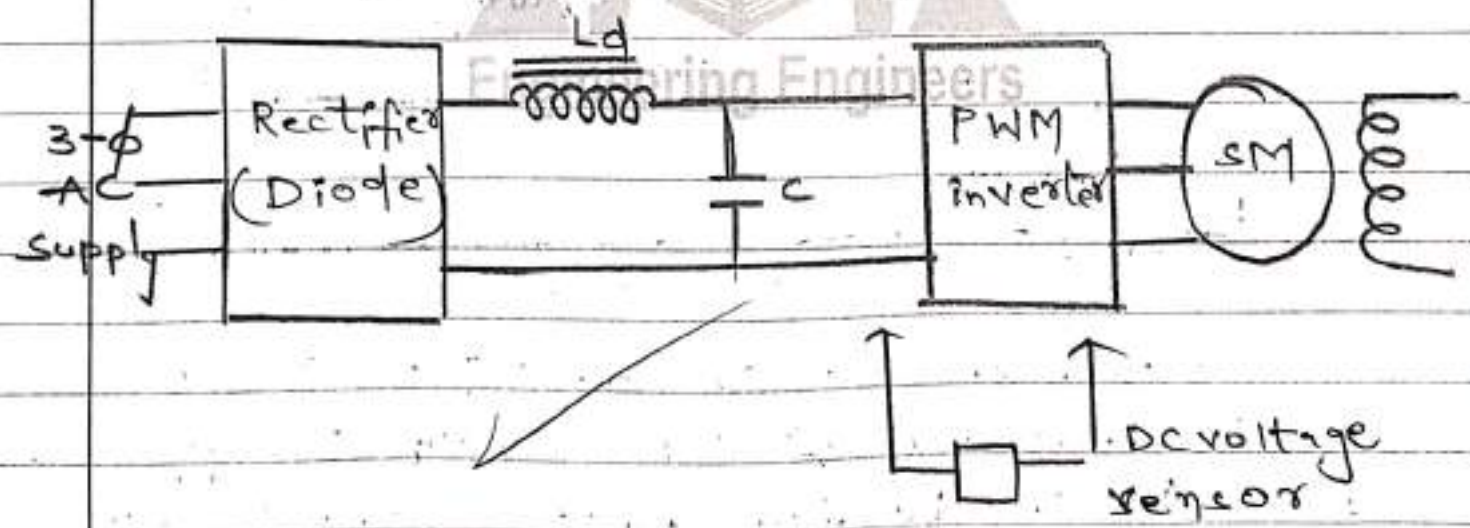
ii) motor.

There are 3 methods

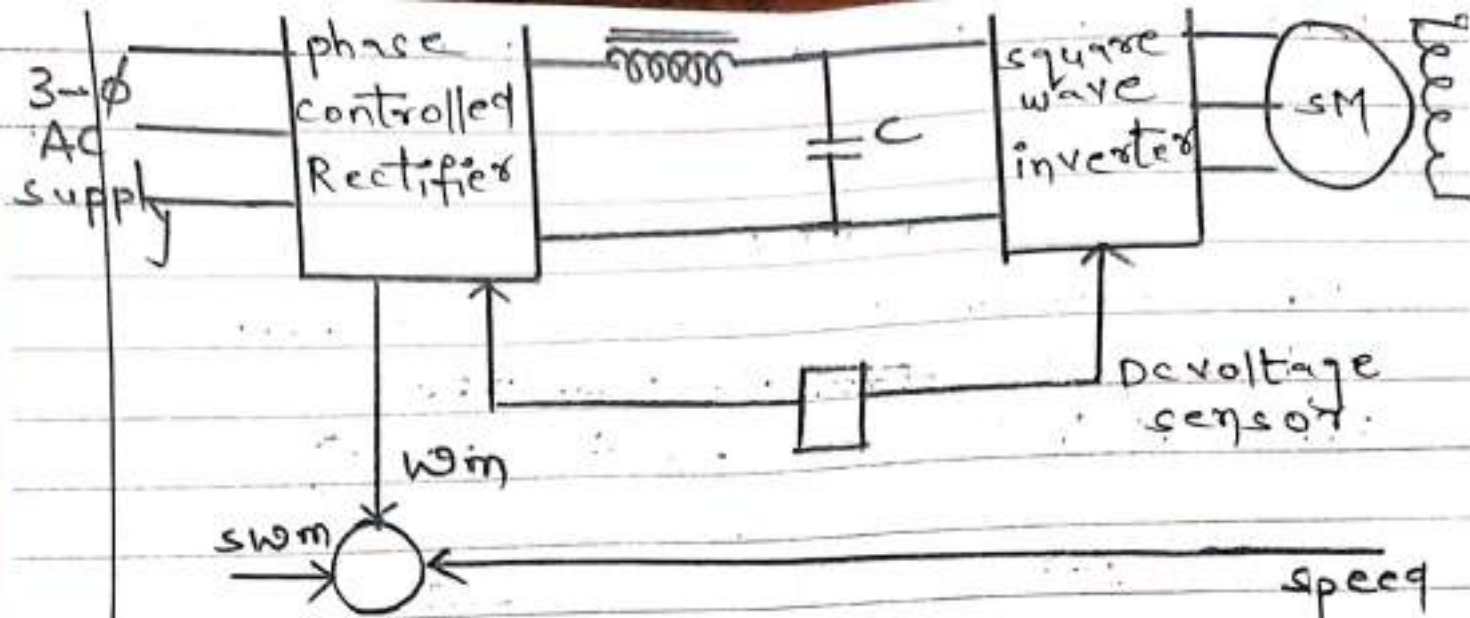
- 1) square wave inverter
- 2) PWM inverter
- 3) chopper



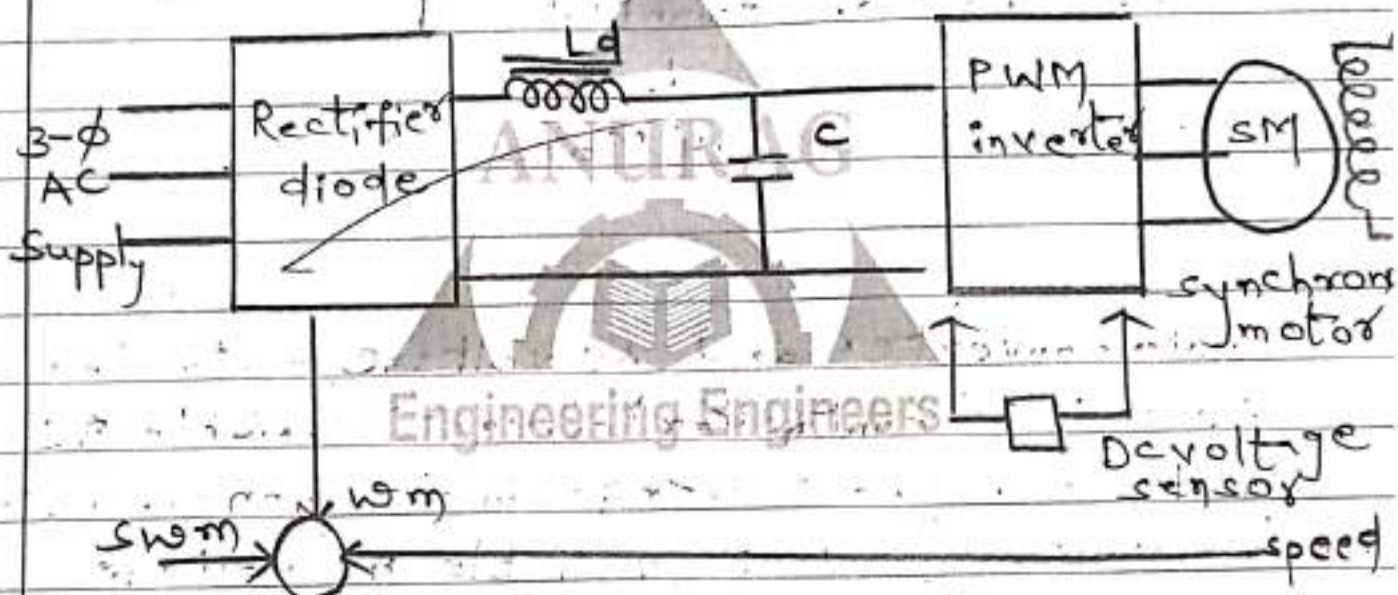
separate control of synchronous motor  
fed square wave inverter



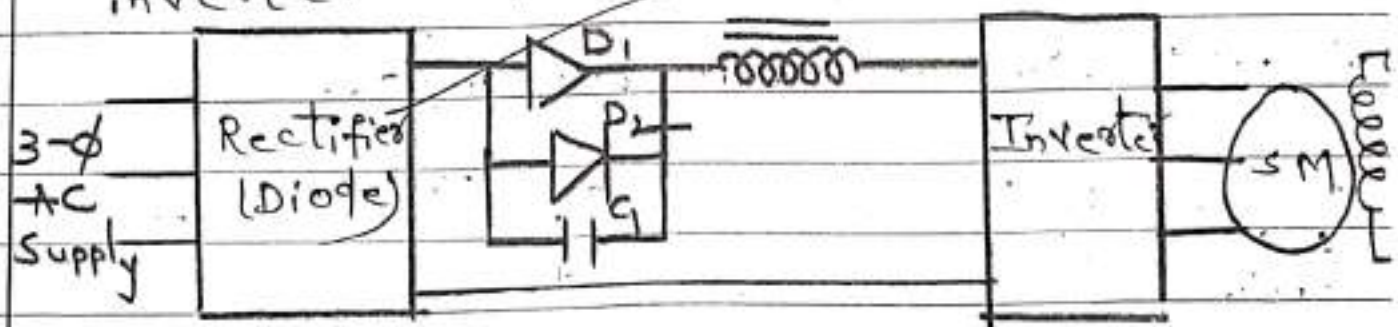
separate control of synchronous motor  
PWM inverter



self excited synchronous motor of a square wave inverter



self excited synchronous motor of a PWM inverter



Dual converter

operation :-

AC supply is given to rectifier. Rectifier input is AC it converts AC to DC and that DC is given to inverter. inverter converts

run.

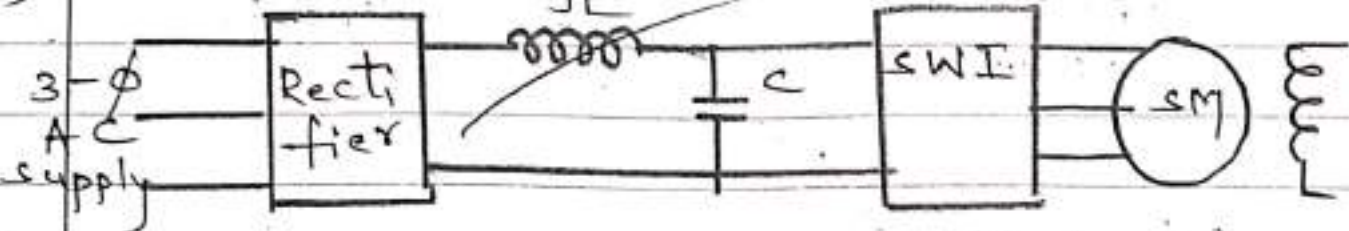
### PART-A

- 1) Types of control strategies in a DC chopper
- 1) Time ratio control strategy (TRC)
  - 2) current limit control strategy (CLC)

VSI	CSI
1) less reliable	1) more reliable
2) It needs feedback diode	2) it need not feedback diode
3) less cost	4) More cost

- 3) cyclo converter and AC voltage controller
- AC voltage controller converts variable AC voltage without change in frequency. cyclo converter converts variable AC voltage with change in frequency.

- 4) self control of synchronous motor



- 5) cyclo converter converts variable AC voltage into fixed AC voltage with change in frequency.

Program			YEAR	SEMESTER	MID EXAMINATION					
B.Tech.	M.Tech.	M.B.A.	III	VI	II					
HALL TICKET NO.			Regulation : R18	Branch or Specialization: EEE						
2 1 0 1 1 A 0 2 1 2			Signature of Student: K. Sumanth							
Course: Power Semiconductor Drives			Signature of invigilator with date:							
Q.No. and Marks Awarded			Signature of the Evaluator: S S							
1	2	3	4	5	6	7	8	9	10	11
0	1	0	1	1	2			2	3	
			Maximum Marks	20	Marks Obtained	10				

(Start Writing From Here)

## PART-B

6 Ans:-

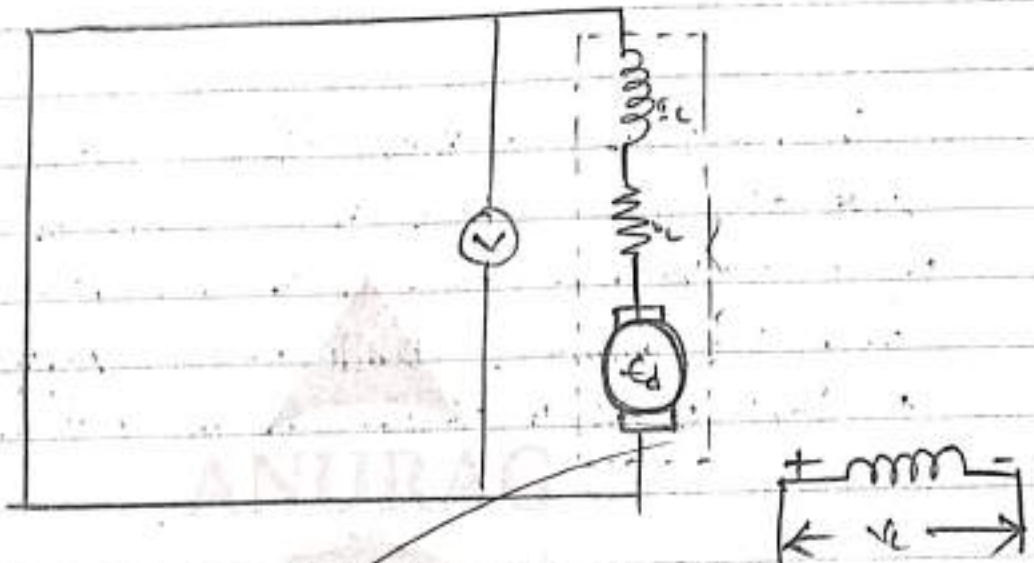
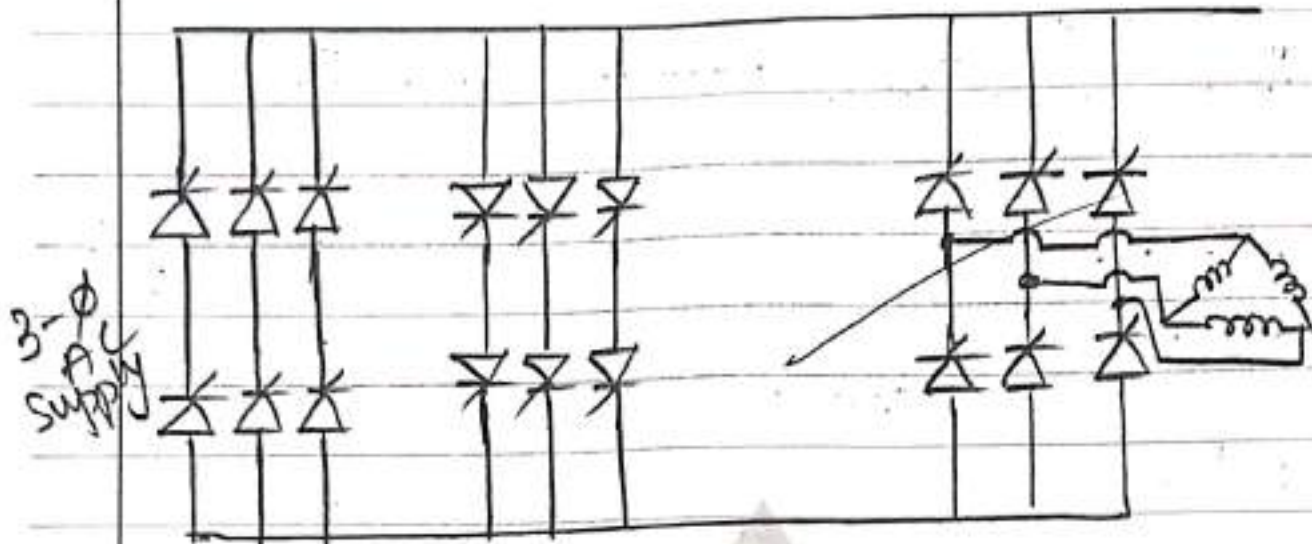


Fig. Chopper control of a series DC Motor

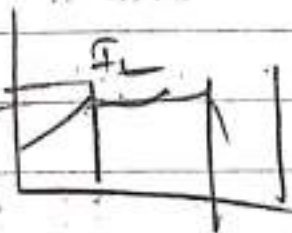
- In the above fig of the chopper ~~control~~ controller of a series DC motor
- By the connecting the ~~ed~~ to  $\alpha$
- The voltage across by the moving through the one phase to another direction of an DC controller.
- Then the Differential type of an stable controlled an ~~control~~ term in a phase used  $\alpha$  ( $\alpha$ ) of an

9 Ans:- Explanation of CSI:-



closed loop of CSI in the ~~closed~~ CSI controller of an ~~and~~ Alternative controller in the phases of an individual By CSI closed loop controller in the phases are induction through the sustainable loads. By the Applying 3- $\phi$  AC Supply through (R) Direction of a CSI loop

2



QAns:- Explanation of separate controlled Synchronous Motor Drive.

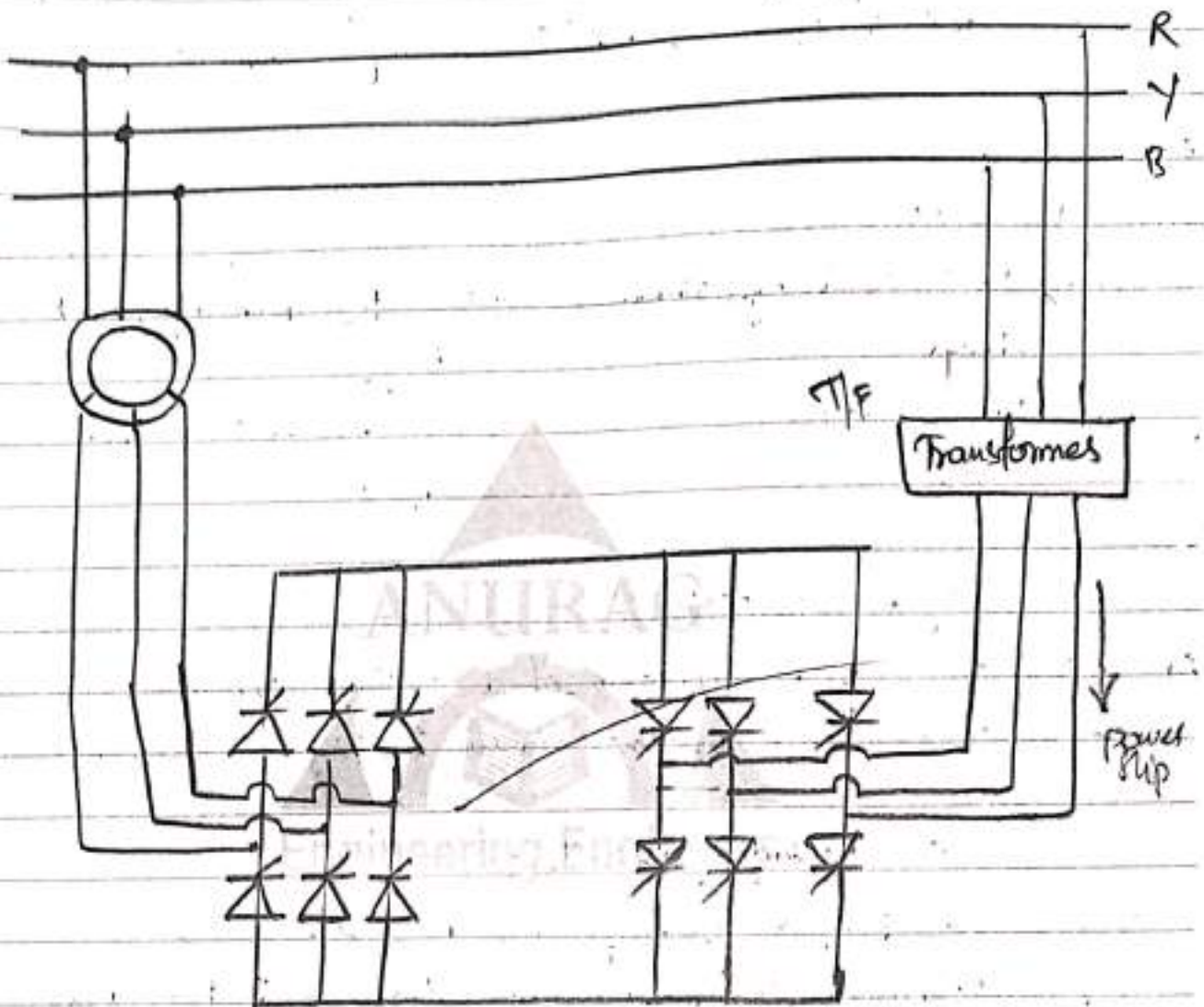


Fig:-- Operation of a Synchronous Motor

- In the separate controlled of a synchronous Motor Drive of an individual output.
- The flexible and power slip controller is used the voltage Meter then the supplying and flows through the three phase motor.
- Are the combinatorial efficiency through the cell controller.
- Then self-control of a synchronous motor Drive in the individual controller.



## PART - A

1 Ans:-

- In a lagging factor of  $\cos \phi$  DC Chopper Series Controller.
- And DC series motor strategies of DC Chopper.

2 Ans:-

- | <u>VSI</u>                     | <u>CSI</u>                        |
|--------------------------------|-----------------------------------|
| → It is field operational loop | → It is the Non operational loop. |
| → By the Excitve loop of VSI   | → In the non excitve loop of CSI  |

Cyclo converter:-

- 3 Ans:-
- In the cyclo converter of a Voltage Terminal
  - In the states of the various individual converters.

AC voltage controller:-

- In the AC voltage are the Alternative
- By the apply the voltage terminal in the source inductance.

4 Ans:-

The self-control of a synchronous Motor in the separately controlled the operational controller of Differences. It's know as self-control.

5 Ans:-

- The concept of the cycloconverter of AC voltage
- It works as the individual converter.

Program		
B.Tech.	M.Tech.	M.B.A.

HALL TICKET NO.										
2	1	C	1	1	A	0	2	0	1	

Course: PSD
-------------

Q.No. and Marks Awarded										
1	2	3	4	5	6	7	8	9	10	11
	1	1	0	0			2			3

YEAR	SEMESTER	MID EXAMINATION
III	II	II

Regulation: R18	Branch or Specialization: EEE
-----------------	-------------------------------

Signature of Student: Anilfady..
----------------------------------

Signature of invigilator with date: 16/06/24
--

Signature of the Evaluator:
-----------------------------

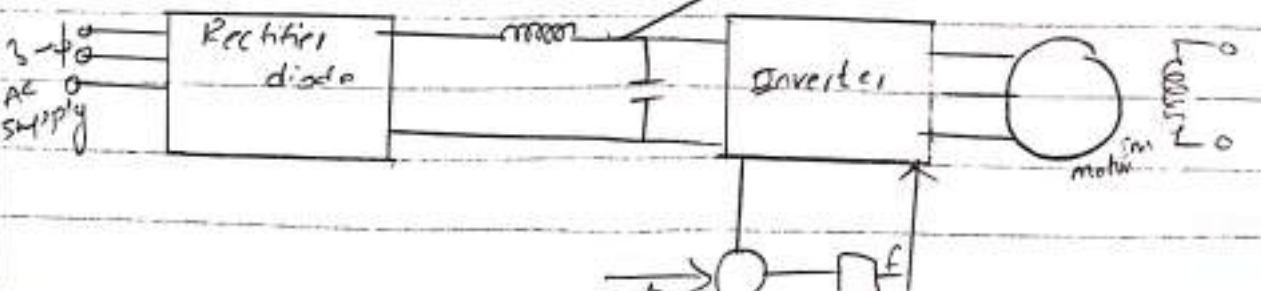
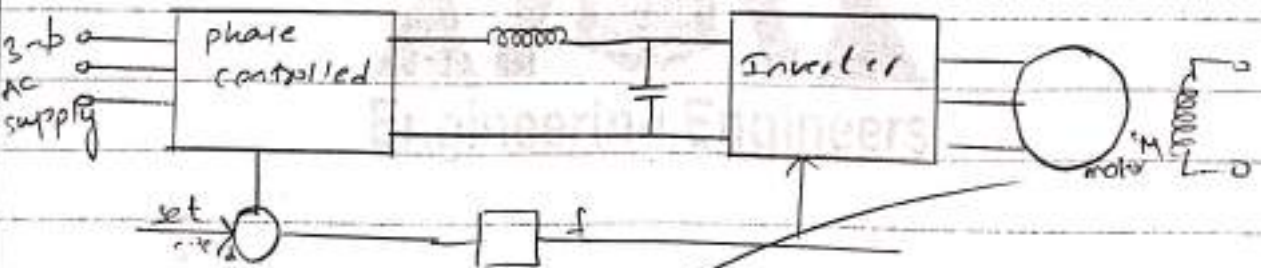
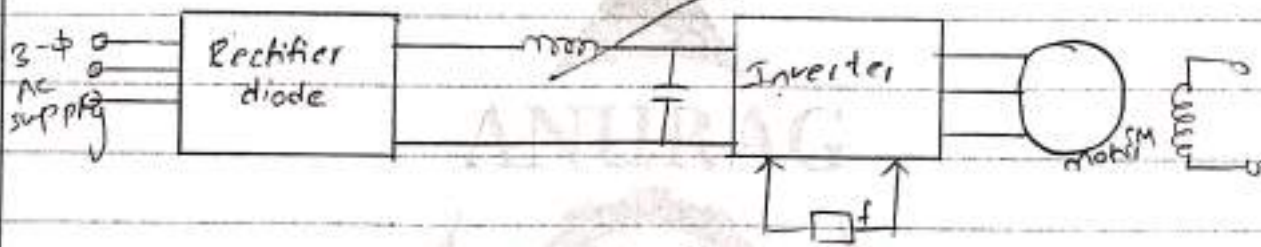
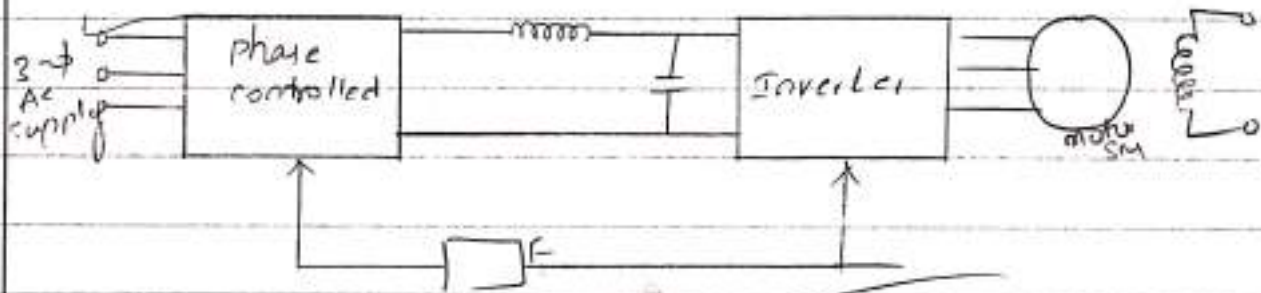
  

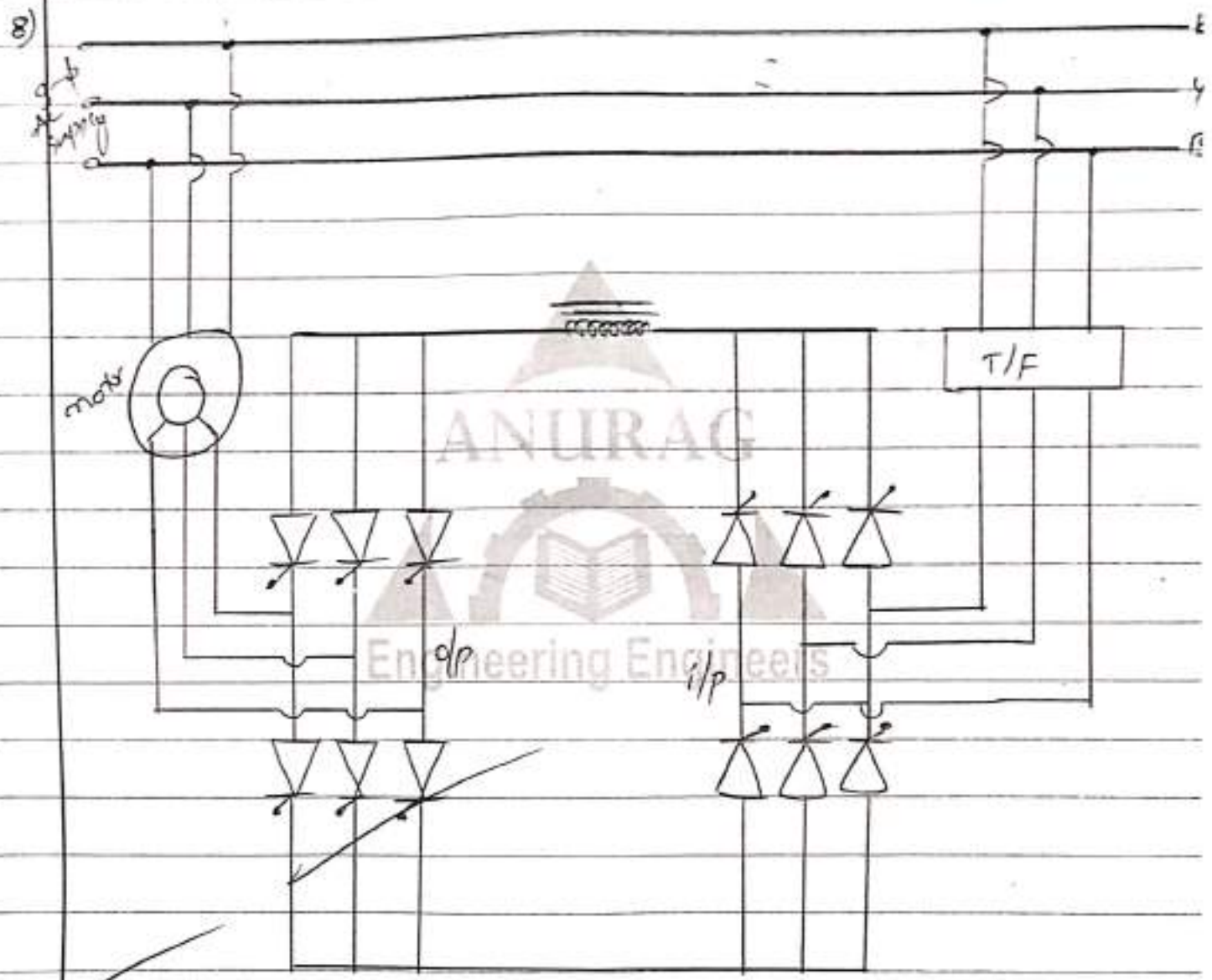
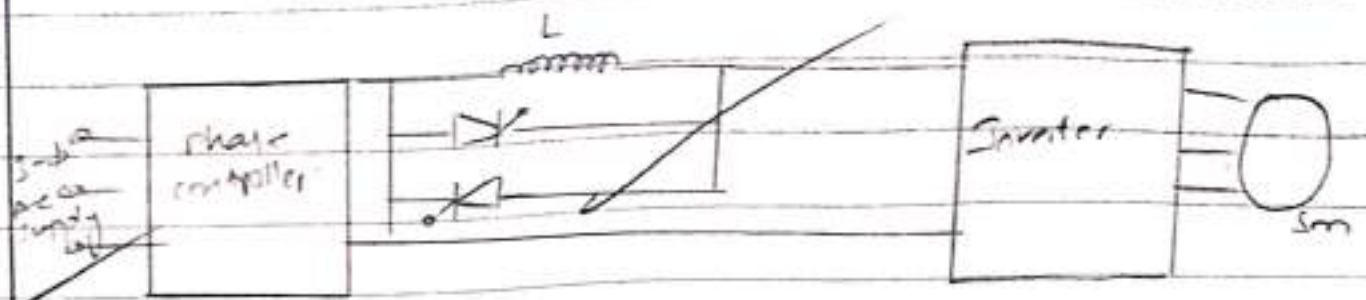
Maximum Marks	20	Marks Obtained	07
---------------	----	----------------	----

(Start Writing From Here)

### PART-B

11. VSI Method of speed control of synchronous motor





3- $\phi$  induction motor from starter side

PART - A

2) CSI

VSI

\* less efficiency

\* high efficiency

\* High cost

\* less cost

\* It is in current mode

\* It is in voltage mode.

3) • cyclo converter is converter AC voltage to the DC voltage.

• AC voltage controller is controller fixed voltage to variable voltage.

4) The controlling of fluctuation in current is ment by self-control of synchronous motor.

5)

00

## POWER SEMICONDUCTOR DRIVES

## Assignment

1) Two independent  $1-\phi$  semi-converters are supplying the armature and field circuits of the separately excited DC motor for controlling its speed. The firing angle of the converter, supplying the field is adjusted such that maximum field current flows. The machine parameters are; armature resistance of  $0.25\text{-}\Omega$  field circuit resistance of  $147\text{-}\Omega$  motor voltage constant  $K_v = 0.7032\text{V/A-rad/sec}$ . The load torque is  $45\text{N-m}$  at  $1000\text{rpm}$ . The converters are fed from a  $208\text{V}, 50\text{Hz}$  A.C supply. The friction and windage losses are neglected. The inductance of the field and armature circuits are sufficient enough to make the armature and field currents continuous and ripple free.

Determine

- The Field current
- The delay angle of the armature converter
- Input p.f of the armature circuit converter

sol Given that

$$V_s = 208\text{V}, 50\text{Hz}$$

$$N = 1000\text{rpm}$$

$$R_a = 0.25\text{-}\Omega$$

$$R_f = 147\text{-}\Omega$$

$$K_v = 0.7032\text{ V/A-rad-sec}$$

$$T = 45\text{N-m}$$

$$i) V_f = \frac{V_m}{\pi} (1 + \cos \alpha)$$

$$V_f = \frac{\sqrt{2} V_s}{\pi} (1 + \cos \alpha)$$

$$V_f = \frac{\sqrt{2} \times 208}{\pi} [1 + \cos(0^\circ)]$$

$$\therefore V_f = 187.2 \text{ V}$$

$$I_f = \frac{V_f}{R_f}$$

$$= \frac{187.2}{147}$$

$$\therefore I_f = 1.27 \text{ Amp}$$

$$\text{ii) } T = k \phi I_a \quad [\phi \propto I_f = 1.27 \text{ A}]$$

$$45 = 0.7032 \times 1.27 \times I_a$$

$$45 = 0.893 \times I_a$$

$$I_a = \frac{45}{0.893}$$

$$\therefore I_a = 50.4 \text{ A}$$

$$E_b = k \phi \omega_m$$

$$= k \phi \frac{2\pi \times N}{60}$$

$$= 0.7032 \times 1.27 \times \frac{2\pi \times 1000}{60}$$

$$= 0.893 \times 104.71$$

$$E_b = 93.52 \text{ V}$$

$$V_a = E_b + I_a R_a$$

$$= 93.52 + 50.4 \times 0.25$$

$$V_a = 106.12 \text{ V}$$

$$V_a = \frac{V_m}{\pi} (1 + \cos \alpha)$$

$$V_a = \frac{\sqrt{2} \times V_s}{\pi} (1 + \cos \alpha)$$

$$106.12 = \frac{\sqrt{2} \times 208}{\pi} (1 + \cos \alpha)$$

$$106.12 = 93.63 (1 + \cos \alpha)$$

$$(1 + \cos \alpha) = \frac{106.12}{93.63}$$

$$(1 + \cos \alpha) = 1.133$$

$$\cos \alpha = 1.133 - 1$$

$$\cos \alpha = 0.133$$

$$\alpha = \cos^{-1}(0.133)$$

$$\boxed{\alpha = 82.35}$$

iii) Input power factor =  $\frac{V_a I_a}{V_s \cdot I_{s \text{rms}}}$

$$\text{power output} = V_a I_a$$

$$= 106.12 \times 50.4$$

$$\therefore \text{power output} = 5348.4 \text{ Watts}$$

$$\text{power input} = V_s I_{s \text{rms}}$$

$$I_{s \text{rms}} = I_a \left[ \frac{\pi - \alpha}{\pi} \right]^{1/2}$$

$$= 50.4 \left[ \frac{\pi - 82.35}{\pi} \right]^{1/2}$$

$$= 50.4 \sqrt{\frac{180 - 82.35}{180}}$$

$$\therefore \boxed{I_{s \text{rms}} = 37.12}$$

$$\text{power input} = V_s \cdot I_{s \text{rms}}$$

$$= 208 \times 37.12$$

$$\therefore \text{power i/p} = 7720.96 \text{ Watts}$$

Now, Input power factor =  $\frac{V_a I_a}{V_s \cdot I_{s \text{rms}}}$

$$= \frac{5348.4}{7720.96}$$

$$\boxed{I/p \text{ P.f.} = 0.69}$$

- 2) A 220V, 1000rpm, 60A separately excited Dc Motor has an armature resistance of 0.1 $\Omega$ . It is fed from 1- $\phi$  Fully converter with an ac source voltage of 230V, 50Hz. Assuming continuous conduction, compute
- firing angle for rated motor torque at 600rpm
  - firing angle for rated motor torque at (-500rpm)
  - Motor speed for  $\alpha = 15^\circ$  and half rated torque

Given that

$$V_s = 230V, 50Hz$$

$$I_a = 60A$$

$$R_a = 0.1\Omega$$

$$N = 1000rpm$$

$$V_a = 220V$$

$$V_a = E_b + I_a R_a$$

$$V_a = K\phi \omega_m + I_a R_a$$

$$220 = K\phi \frac{2\pi N}{60} + I_a R_a$$

$$220 = K\phi \frac{2\pi \times 1000}{60} + 60 \times 0.1$$

$$220 = K\phi (110.71)$$

$$K\phi = \frac{220}{110.71}$$

$$\boxed{K\phi = 1.98}$$

$$i) V_a = E_b + I_a R_a$$

$$\frac{2V_m}{\pi} \cos \alpha = K\phi \omega_m + I_a R_a$$

$$\frac{2V_m}{\pi} \cos \alpha = K\phi \frac{2\pi N}{60} + I_a R_a$$



$$\frac{24\sqrt{2} \times 16 \cos \alpha}{\pi} = k \left( \frac{2\pi I_a}{60} + I_a R_a \right)$$

At  $\theta = 60^\circ$

$$\frac{24\sqrt{2} \times 16 \cos 60^\circ}{\pi} = 1.92 \times \frac{2\pi \times 600}{60} + 60 \times 0.1$$

$$2.07 \times 0.7 \cos \alpha = 120 + 6$$

$$\cos \alpha = \frac{126}{2.07 \times 0.7}$$

$$\cos \alpha = 0.62$$

$$\cos \alpha = 0.62$$

$$\alpha = \cos^{-1}(0.62)$$

$$\alpha = 51.62^\circ$$

ii)  $\frac{24\sqrt{2} \times 16 \cos \alpha}{\pi} = k \left( \frac{2\pi I_a}{60} + I_a R_a \right)$

$$\frac{24\sqrt{2} \times 16 \cos \alpha}{\pi} = 1.92 \times \frac{2\pi I_a}{60} + I_a R_a$$

At  $\theta = -50^\circ$

$$\frac{24\sqrt{2} \times 16 \cos(-50^\circ)}{\pi} = 1.92 \times \frac{2\pi \times (-500)}{60} + 60 \times 0.1$$

$$2.07 \times 0.7 \cos \alpha = -97 + 6$$

$$\cos \alpha = \frac{-91}{2.07 \times 0.7}$$

$$\cos \alpha = -0.47$$

$$\cos \alpha = -0.47$$

$$\alpha = \cos^{-1}(-0.47)$$

$$\alpha = 112.81^\circ$$

iii)  $V_a = E_b + I_a R_a$

$$\frac{24\sqrt{2} \cos \alpha}{\pi} = k \left( \frac{2\pi I_a}{60} + I_a R_a \right)$$

$$\frac{24\sqrt{2} \times 16 \cos(150^\circ)}{\pi} = 1.92 \times \frac{2\pi \times I_a}{60} + I_a \times 0.1$$

$$207.07(-0.866) = 1.98 \times \frac{2\pi N}{60} + \frac{60}{2} \times 0.1$$

$$207.07(-0.866) = 1.98 \times \frac{2\pi N}{60} + 30 \times 0.1$$

$$-179.32 = \frac{12.44N}{60} + 3$$

$$-179.32 - 3 = \frac{12.44N}{60}$$

$$\therefore -182.32 = \frac{12.44N}{60}$$

$$N = \frac{60 \times (-182.32)}{12.44}$$

$$\boxed{N = -879.35 \text{ rpm}}$$

3) The speed of a 125Hp, 600V, 1800rpm separately excited DC motor is controlled by three phase full converter, the converter is operated from a 3- $\phi$ , 480V, 60Hz supply, the rated armature current of the motor is 165A. The motor parameters are  $R_a = 0.0874 \Omega$ ,  $L_a = 6.5 \text{ mH}$  and  $K_a \phi = 0.33 \text{ V/rpm}$  the converter and AC supply are considered to be ideal

Compute

i) No-load speed of firing Angle  $\alpha = 0^\circ$  and  $\alpha = 30^\circ$   
 Assume that No-load, the armature current is 10% of the rated current and is continuous

ii) Find the firing Angle to obtain the rated speed of 1800rpm at rated motor current.

No load condition

5d) The supply phase voltage  $V_{ph} = \frac{V_L}{\sqrt{3}} = \frac{480}{\sqrt{3}} = 277.12 \text{ V}$

$$\text{No load Armature current } I_a = 165 \times 0.1 \\ = 16.5 \text{ A}$$

Now the motor terminal voltage is  $V_a$

$$V_a = \frac{3\sqrt{6} V_{ph} \cos \alpha}{\pi}$$

For  $\alpha = 0^\circ$

$$V_a = \frac{3\sqrt{6} \times 277.12 \cos 0^\circ}{\pi}$$

$$\boxed{V_a = 648.2 \text{ V}}$$

$$\therefore \text{Back emf } E_b = V_a - I_a R_a$$

$$= 648.2 - 16.5 \times 0.0874$$

$$= 646.75 \text{ V}$$

No-load speed is

$$N_{NL} = \frac{E_b}{K_a \phi} = \frac{646.75}{0.33}$$

$$\boxed{N_{NL} = 1959.848 \text{ rpm}}$$

For  $\alpha = 30^\circ$

$$V_a = \frac{3\sqrt{6} \times 277.12 \cos 30^\circ}{\pi}$$

$$V_a = 561.36 \text{ V}$$

$$E_b = V_a - I_a R_a$$

$$= 561.36 - 16.5 \times 0.0874$$

$$= 559.91 \text{ V}$$

$$\text{No load speed } N_{NL} = \frac{E_b}{K_a \phi} = \frac{559.91}{0.33}$$

$$\boxed{N_{NL} = 1696.7 \text{ rpm}}$$

ii) Full load condition

Motor back emf  $E_b$  at 1800 rpm

$$E_b = N \times K_a \phi$$

$$E_b = 1800 \times 0.33$$

$$E_b = 594 \text{ V}$$

Voltage at rated armature current is

$$V_a = E_b + I_a R_a \\ = 594 + 165 \times 0.0874$$

$$\boxed{V_a = 608.42 \text{ V}}$$

$$V_a = \frac{3\sqrt{6} \times 277.12 \cos \alpha}{\pi}$$

$$\cos \alpha = \frac{\pi \times 608.42}{3\sqrt{6} \times 277.12}$$

$$\cos \alpha = 0.9386$$

$$\alpha = \cos^{-1}(0.9386)$$

$$\boxed{\alpha = 20.18^\circ}$$

- 4) A 220V, 1500rpm, 50A Separately excited motor with armature resistance of  $0.5 \Omega$  is fed from a three phase fully controlled rectifier. Available ac source has a line voltage of 440V, 50Hz. A star/delta connected transformer used to feed the armature so that motor terminal voltage equals rated voltage when converter firing angle is zero. Calculate transformer turns ratio. Determine the value of firing angle when i) motor is running at 1200rpm and rated torque. ii) when motor is running at (-800) rpm and twice the rated torque. Assume continuous condition.

For three phase fully controlled rectifier

$$V_{\max} = \frac{\pi}{3} \frac{V_a}{\cos \alpha}$$

For rated motor terminal voltage firing angle

$$\alpha = 0$$

$$V_{\max} = \frac{\pi}{3} \frac{220}{\cos 0}$$

$$= 230.4 \text{ V}$$

RMS converter input voltages between lines

$$\frac{V_{\max}}{\sqrt{2}} = \frac{230.4}{\sqrt{2}} = 162.9 \text{ V}$$

For star-delta transformer connection, the turns ratio b/w<sup>n</sup> phase windings primary and secondary

$$K = \frac{440/\sqrt{3}}{162.9}$$

$$\boxed{K = 1.559}$$

i) At 1500 rpm, back emf  $E_b$

$$E_b = V - I_a R_a$$

$$= 220 - 50 \times 0.5$$

$$\boxed{E_b = 195 \text{ V}}$$

At 1200 rpm

$$E_b = \frac{1200}{1500} \times 195$$

$$\boxed{E_b = 156 \text{ V}}$$

Average output voltage

$$V_a = E_b + I_a R_a$$

$$= 156 + 50 \times 0.5$$

$$= 181 \text{ V}$$

Since

$$V_a = \frac{3V_m \cos \alpha}{\pi}$$

$$\cos \alpha = \frac{\pi}{3} \frac{V_a}{V_m} = \frac{\pi}{3} \frac{181}{230.4}$$

$$\cos \alpha = 0.8227$$

$$\alpha = \cos^{-1}(0.8227)$$

Firing Angle

$$\boxed{\alpha = 34.65^\circ}$$

ii) At (-800) rpm, back emf

$$E_b = \frac{-800}{1500} \times 195$$

$$E_b = -104V$$

Average output voltage

$$V_a = E_b + I_a R_a$$

$$= -104 + 50 \times 0.3$$

$$V_a = -54V$$

$$\cos \alpha = \frac{\pi V_a}{3 V_m}$$

$$= \frac{\pi}{3} \frac{-54}{230.4}$$

$$= -0.2454$$

$$\alpha = \cos^{-1}(-0.2454)$$

$$\alpha = 104.20$$

firing  
Angle

5) A 220V, 970rpm, 100A DC Separately excited motor has an armature of 0.05Ω. It is braked by plugging from an initial speed of 1000rpm

Calculate

a) Resistance to be placed in armature circuit to limit braking current twice the full load value

b) Braking torque.

c) Torque when the speed fallen to zero.

At 970rpm

$$E_{b1} = V - I_a R_a$$

$$= 220 - 100 \times 0.05$$

$$= 215V$$

Back emf at 1000rpm

$$\frac{E_{b2}}{E_{b1}} = \frac{N_2}{N_1}$$

$$\frac{E_{b2}}{215} = \frac{1000}{970}$$

$$\boxed{E_{b2} = 221.65 \text{ V}}$$

- At 1000 rpm

a) for plugging operation

$$I_a = 2 \times 100 \\ = 200$$

$$R_B + R_a = \frac{E_{b2} + V}{I_a} = \frac{221.65 + 220}{200} = 2.21 \Omega$$

$$R_B = 2.21 - 0.05 \\ = 1.16 \Omega$$

$$\boxed{R_B = 1.16 \Omega}$$

b) Torque =  $\frac{E_{b2} I_a}{\omega_m} = \frac{221.65 \times 200}{1000 \times \frac{2\pi}{60}}$

$$\boxed{T = 423.4 \text{ N-m}}$$

c) At zero speed  $E_b = 0$

$$I_a = \frac{V}{R_B + R_a} = \frac{220}{2.21} \\ = 99.55 \text{ A}$$

$$T \propto I_a$$

$$\frac{T_2}{T_1} = \frac{I_{a2}}{I_{a1}}$$

$$T_1 = 423.3 \text{ N-m}$$

$$I_{a1} = 200 \text{ A}$$

$$I_{a2} = 99.55 \text{ A}$$

$$\frac{T_2}{423.3} = \frac{99.55}{200}$$

$$\boxed{T_2 = 210.7 \text{ N-m}}$$

→

Name :- J. Jayanth

Roll No :- 2215A01023

Subject :- P&D

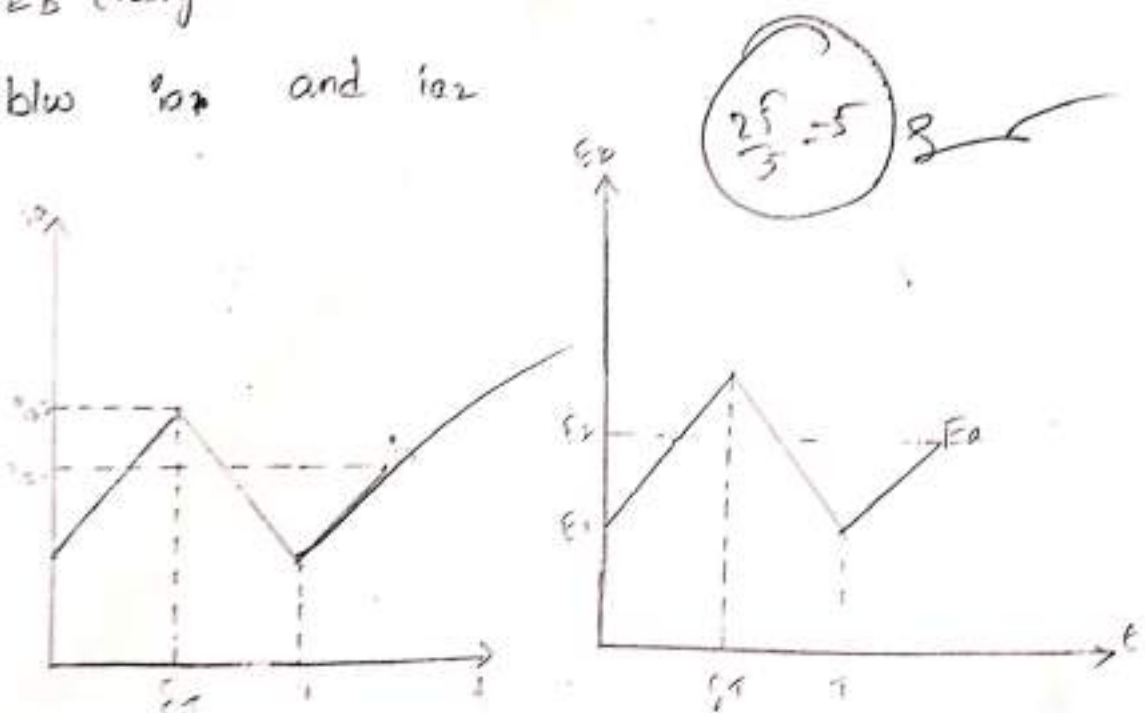
Branch :- B-Tech (EEE)

b) Explain about chopper control of series motor

Motoring control of series motor:

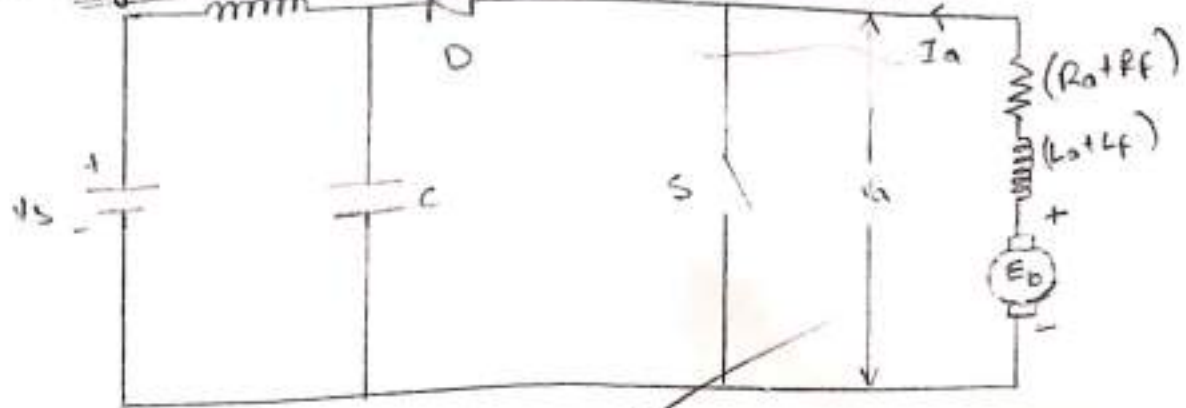
\* The main problem in the analysis of a chopper controlled series motor arises due to the non-linear relation between the induced voltage 'E' and armature current 'I<sub>a</sub>', because of the saturation in the magnetization characteristics.

\* At a given motor speed, the instantaneous back emf E<sub>b</sub> changes b/w E<sub>1</sub> and E<sub>2</sub> as  $\alpha$  changes b/w  $\alpha_{on}$  and  $\alpha_{off}$ .





## \* Regenerative Braking of DC Series Motor



- \* When the chopper control is absent, a series motor cannot be braked by regenerative braking.
- \* With chopper control it is possible to brake a series motor using regenerative braking.
- \* However regenerative braking of dc series motor is not so simple and effective as that of separately excited motor.
- \* During regenerative braking, series motor functions as self excited series generator.
- \* For self excitation current flowing through the winding should assist residual magnetism.
- \* Therefore, when changing from motoring to braking connection, when armature current reverses field current should flow in the same direction.
- \* This is achieved by reversing the field w.r.t armature when changing from motoring to braking operation.
- \* Wm can be found out from the following equations.

- \* Since motor works as a self excited generator when changing from motoring to braking, field should be reversed.
- \* The only difference between this circuit and dynamic braking circuit is the addition of semiconductor switch,  $S$  in parallel with the braking resistance,  $R_B$ .

2) Draw a block schematic diagram for automatic speed control of three phase induction motor using solid state AC voltage controller and stator side.

\* The closed loop speed control for 3- $\phi$  induction motor is a stator voltage controller.

\* This system consists of a power circuit, 3- $\phi$  IM, tachogenerator and control circuits.

\* A DC tachogenerator is coupled with induction motor shaft.

\* This tachogenerator generates a voltage proportional to the motor speed.

\* The generated voltage is equal to the actual speed of the motor.

\* This voltage is compared with dc reference voltage (reference speed).

\* The difference between these two voltages are compared in comparator and output voltage is error signal voltage.

\* This voltage is amplified by amplifier and fed to the thyristor gating circuits.

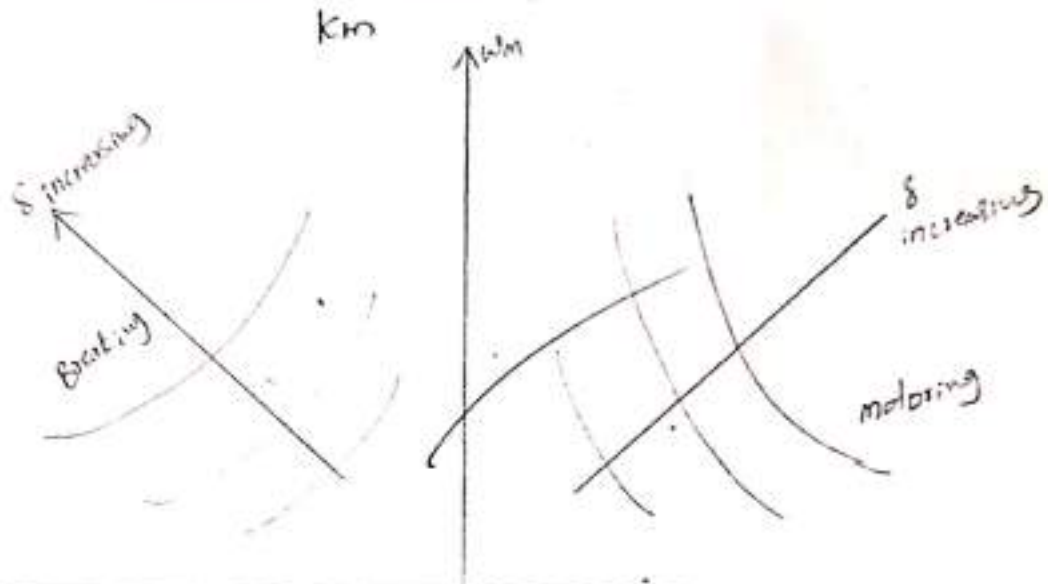
$$E = v_a + I_a (R_a + R_f)$$

But,  $v_a = sV$

$$E = sV + I_a (R_a + R_f)$$

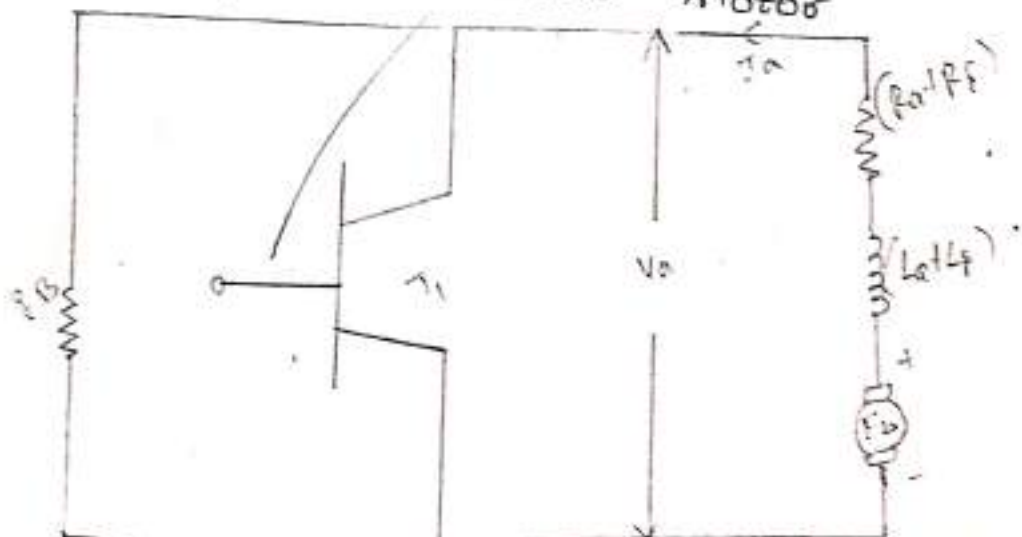
$$k_m \omega_m = sV + I_a (R_a + R_f)$$

$$\omega_m = \frac{sV + I_a (R_a + R_f)}{k_m}$$



- \* The nature of speed-torque characteristics give unstable operation with most loads.
- \* Therefore regenerative braking of series motor is difficult
- \* The main problems are the difficulty in the initial build up of the back emf and poor stability.

### Dynamic Braking of DC series motor

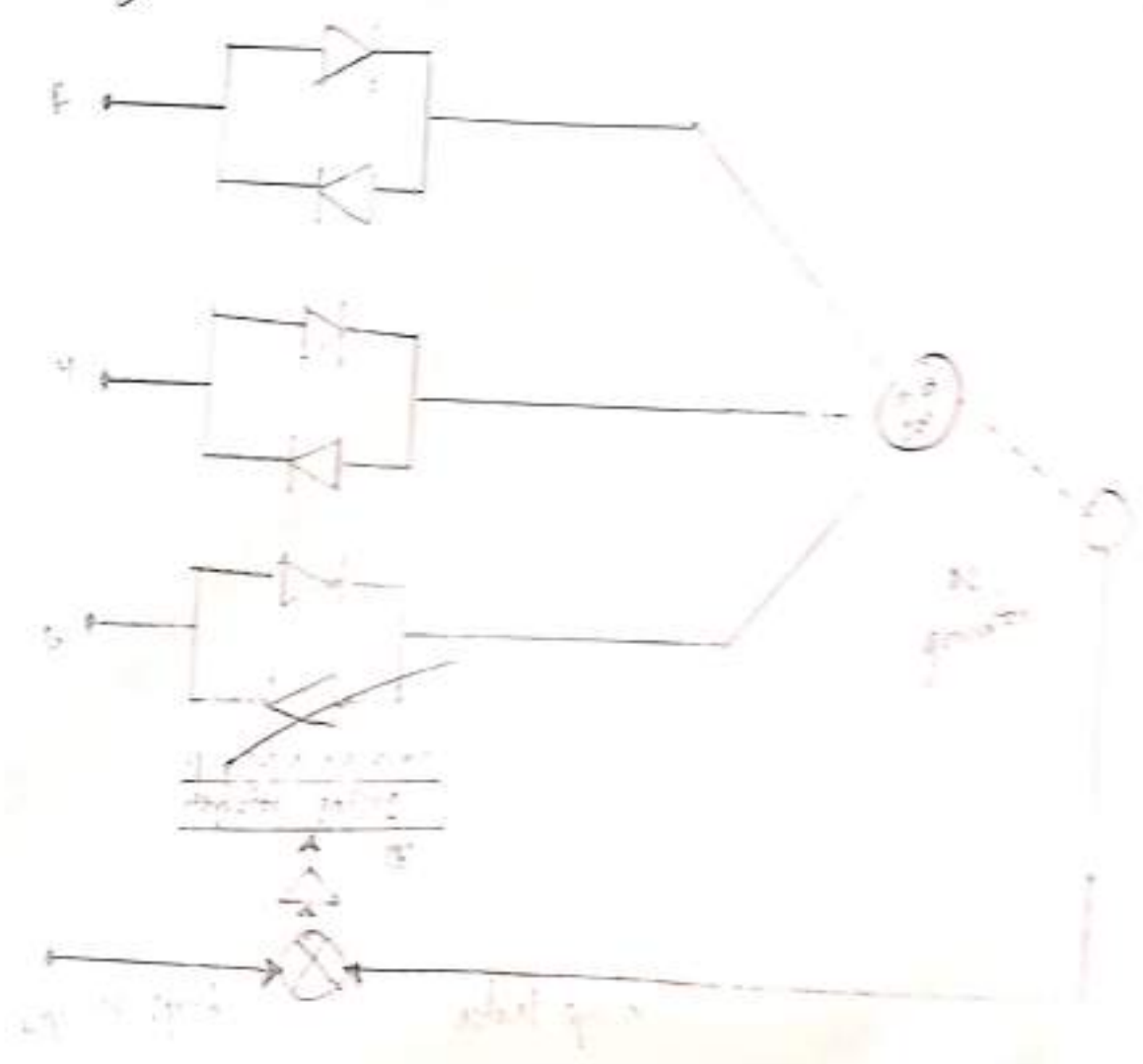


\* This controls the thyristor firing angles and these by changes the terminal voltage and hence the motor speed changes.

\* If the reference speed is greater than actual speed, the conduction periods of the SCRs are increased.

\* The increased stator voltage allows the development of an increased motor torque and hence the motor speed also increases.

\* If the actual speed is greater than the reference speed, the conduction angle of SCRs are reduced and the motor torque decreases as well as reduced the motor speed.

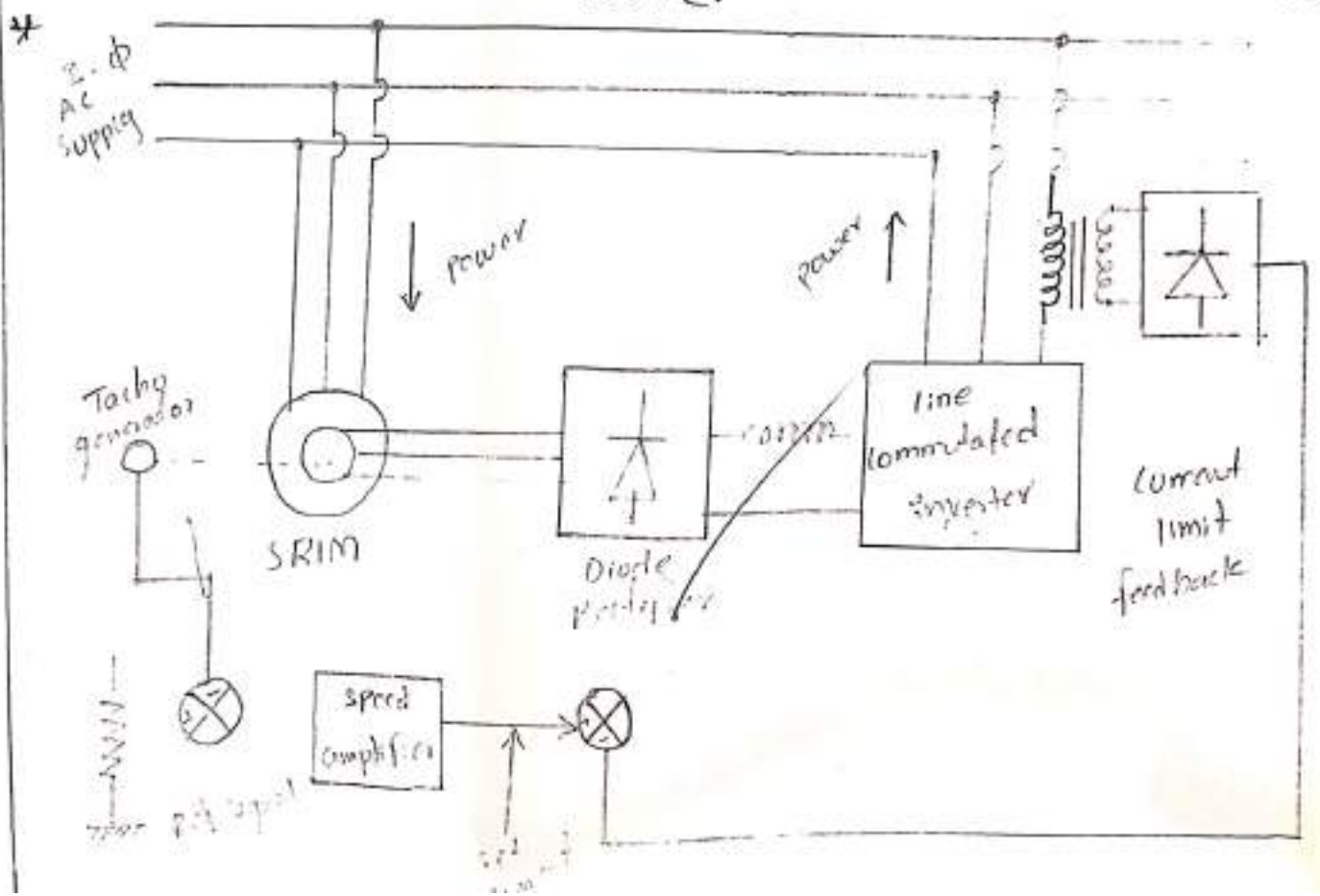


\* When the motor speed is equal to the reference speed, the conduction angles are just sufficient to allow the development of a motor torque.

\* This motor torque is equal to the load torque. In a high-gain feedback system, the desired speed can be maintained and there is no necessity for the motor to have a flat speed characteristic, since the output speed is determined by the reference signal rather than the open-loop characteristics of the motor.

\* The stable operation point of the induction characteristics may be obtained at any motor speed-torque characteristics.

3) Draw and explain closed loop operational static Kramer controlled drive.



- \* Actual speed is compared with a reference voltage (ref speed) the actual speed is fed back from a tachogenerator, which is compared to the rpm.
- \* The error voltage is amplified by the speed amplifier and set the desired current reference
- \* The current feedback loop adjust the current of the system by controlling the firing angles of the inverter.
- \* This error voltage is amplified by the current amplifier and fed to the firing angle control circuit of the inverter.
- \* This is compared with the current reference set by the speed amplifier.
- \* Thus, in this generator speed error produces a motor torque which, again reduces the error.
- \* The acceleration and deceleration is fairly smooth
- \* Thus the current can be limited to any desired value even under the stalled condition.

4.

Draw the block diagram of a closed loop synchronous motor drive fed from VSI and explain?

Now a days more attention is being paid towards understanding the behaviour of the synchronous motor fed from a VSI, these drives as said earlier can be developed to have,

- (i) self control mode using a rotor position sensor (or) from phase position of stator voltage.
- (ii) separate control mode using a rotor of frequency from a crystal oscillator. this is the open loop control mode.

Three combinations are possible to provide a variable voltage frequency supply to synchronous motor fed from VSI

- a) square wave inverters
  - b) PWM wave inverters
  - c) chopper with square inverters
- a) Square wave inverters:  
+ here the dc link voltage is variable  $\therefore$  the voltage control is obtained to the inverter using phase controlled rectifier.

\* Since the output voltage is a square wave the inverter is called variable voltage inverter (or) square wave inverter.

b) PWM inverter

\* The second method is to have voltage control within the inverter itself using the principles of PWM.

\* It doesn't have difficulties in commutation at low speeds. It has wide range of speed applications (even till zero speed)

c) Chopper with square wave inverter

\* It has many advantages though it seems to be complex circuitry.

\* Here 3 simple converters are used and it is possible to reduce the link inductance by having synchronous control of the chopper.

Generally a VSI fed SM drive have

⇒ Reasonable efficiency

⇒ Converter cost is high

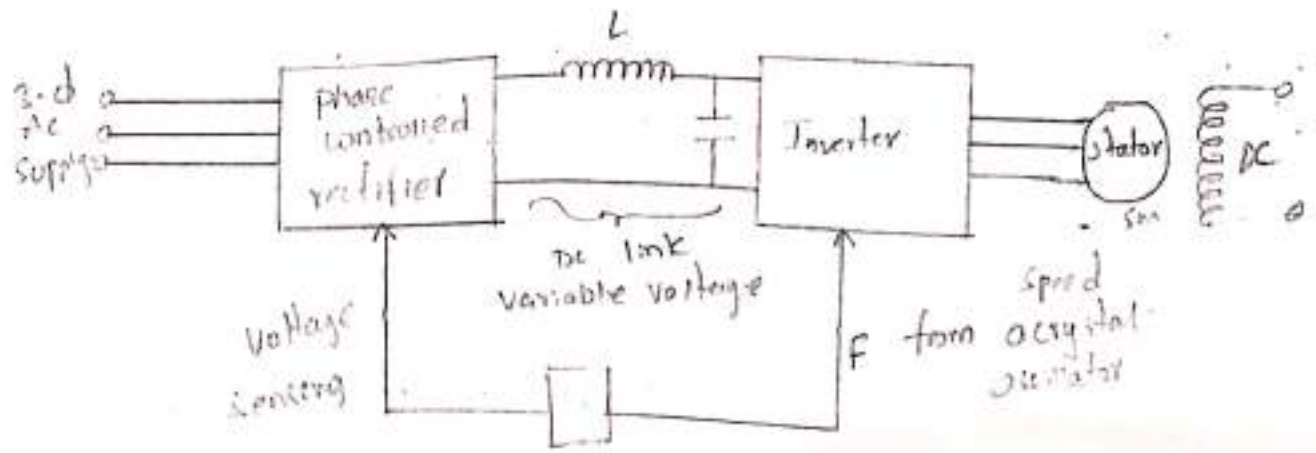
⇒ Multi motor operation is possible

⇒ find application as general purpose drives

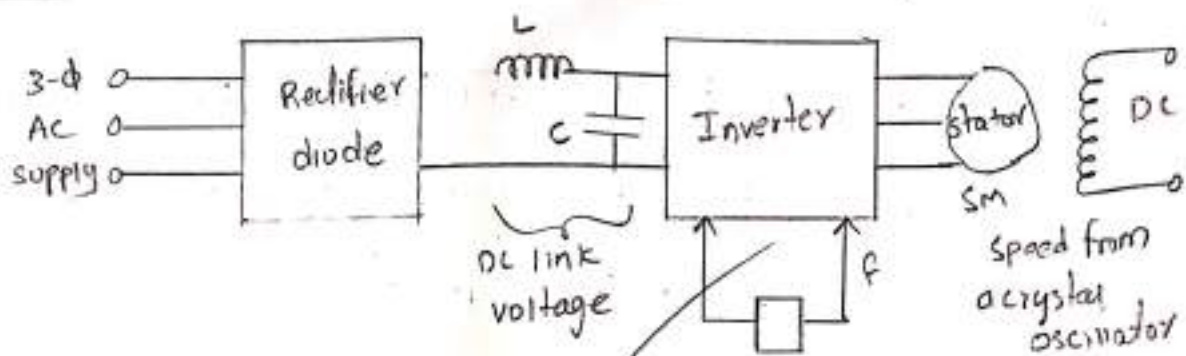
for low and medium power.



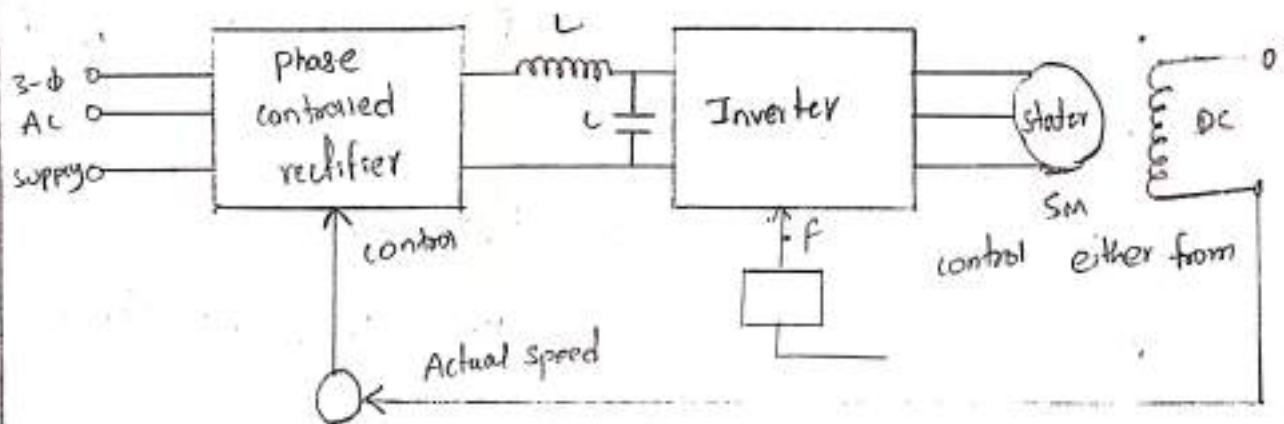




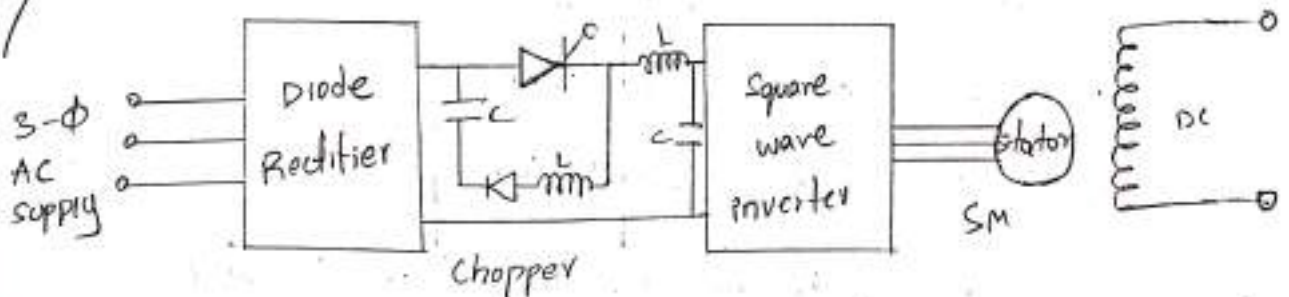
(a) Separate control of SM fed from square wave inverter.



(b) Separate control of SM fed from PWM inverter.



(c) self control of SM fed from square wave

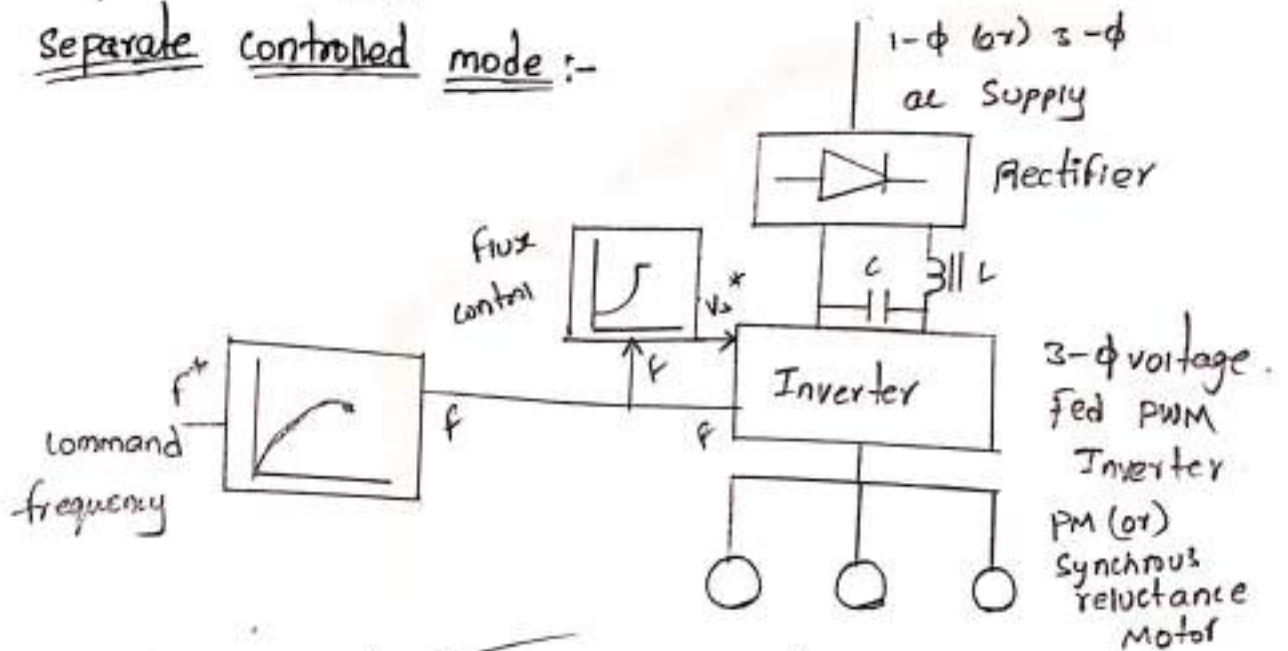


Three simple converter to fed variable voltage & variable freq. to

SM

5) Describe separate control mode and self control mode of operation of a synchronous motor drive in detail and compare them.

Separate controlled mode :-

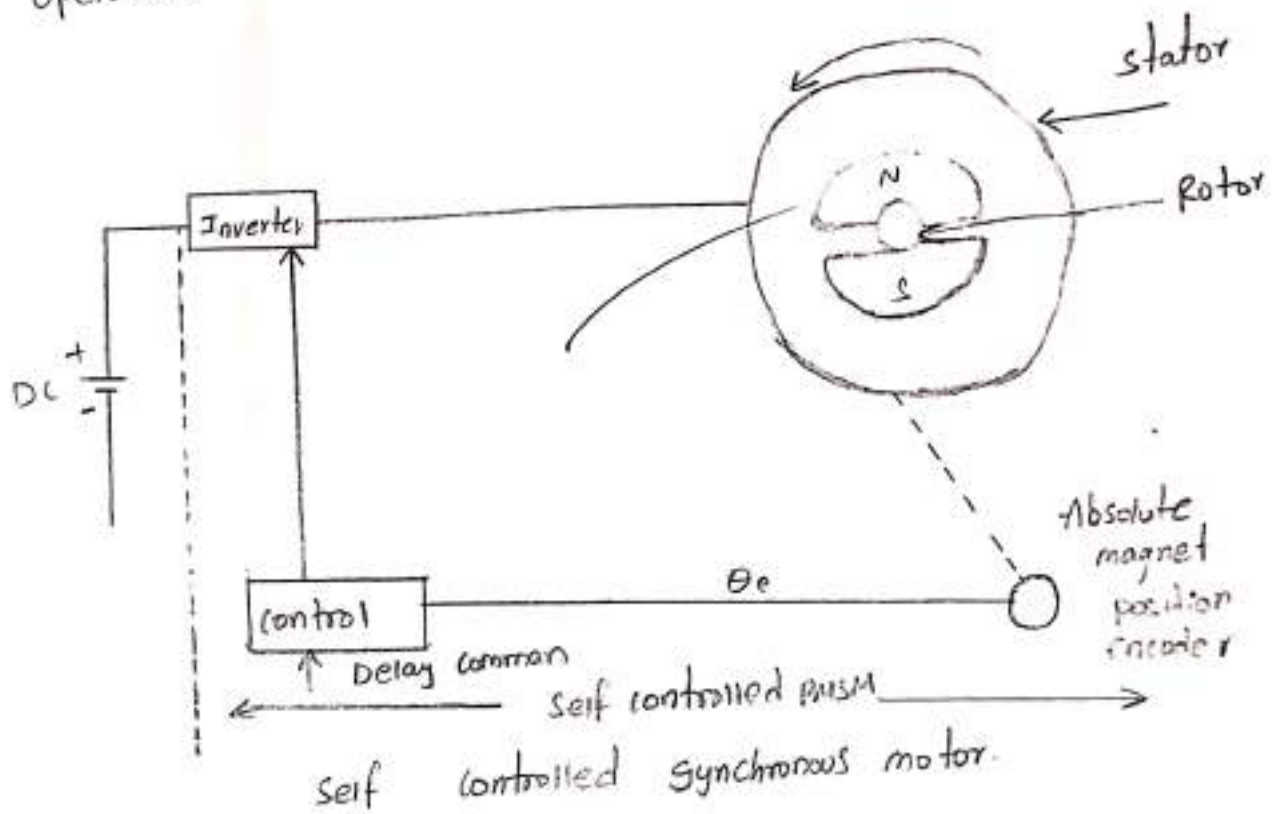


open-loop voltage/Hz Speed control of multiple PM Synchronous motor.

- \* In true synchronous mode, is a open loop mode in which the stator supply frequency is controlled from an independent oscillator.
- \* Here the frequency is gradually changed from its initial to the desired value so that the difference b/w synchronous and rotor speed is always small.
- \* A flux control block is used which changes the stator voltage with frequency so as to maintain constant flux for speed below base speed & constant terminal voltage for speed above base speed.

### Self - Controlled mode :-

- \* In self - controlled mode, the supply frequency is changed so that the synchronous speed is same as that of the rotor speed.
- \* Hence, rotor cannot pull-out of slip and hunting eliminations are eliminated. for such a mode of operation the motor cannot require a damper winding.



- \* In such a case the synchronous machine can supply with inverter work similar to the line commutated inverted works similar to the line commutated.
- \* But then this natural commutation is not possible at low speeds up to 10% of base speed as the machine voltage are insufficient to provide satisfactory commutation.

# **DIGITAL NOTES ON POWER SEMICONDUCTOR DRIVES**

**B.TECH III YEAR - II SEM  
(2023-24)**



**DEPARTMENT OF ELECTRICAL & ELECTRONICS ENGINEERING**

**ANURAG Engineering College**

**(An Autonomous Institution), NAAC A+**

(Approved by AICTE, New Delhi, Affiliated to JNTUH, Hyderabad)

Ananthagiri (V&M), Kodad, Suryapet (Dt). Pin: 508 206.



# ANURAG ENGINEERING COLLEGE

(An Autonomous Institution)

III Year B.Tech. EEE - II Sem

L	T/P/D	C
3	1/-/-	4

## (EE602PC) POWER SEMICONDUCTOR DRIVES

**Prerequisites:** Power Electronics, Electrical Machines-I, II.

### Course Objectives:

- This course deals with control of DC drives using single phase line commutated converters.
- This course deals with control of DC drives using three phase line commutated converters
- This course Provides knowledge about four quadrant operations of DC drives.
- This course deals with control of induction motors drives.
- This course deals with control of synchronous motors drives

### UNIT – I

#### Control of DC motors by Single phase Converters

Introduction to Thyristor controlled Drives, Single Phase semi and Fully controlled converters connected to d.c separately excited and d.c series motors – continuous current operation – output voltage and current waveforms – Speed and Torque expressions – Speed – Torque Characteristics- Problems on Converter fed d.c motors.

### UNIT-II

#### Control of DC motors by Three phase Converters

Three phase semi and fully controlled converters connected to d.c separately excited motors – output voltage and current waveforms – Speed and Torque expressions – Speed – Torque characteristics – Problems.

### UNIT – III

#### Four Quadrant operations of DC Drives & Control of DC motors by Choppers

Introduction to Four quadrant operation – Motoring operations, Electric Braking – Plugging, Dynamic and Regenerative Braking operations. Four quadrant operation of D.C motors by dual converters

Single quadrant, Two –quadrant and four quadrant chopper fed dc separately excited and series excited motors – Continuous current operation – Output voltage and current wave forms – Speed torque expressions – speed torque characteristics – Problems on Chopper fed dc Motors.

### UNIT – IV

#### Control of Induction Motor

From Stator Side: Variable voltage characteristics-Control of Induction Motor by Ac Voltage Controllers – Waveforms – speed torque characteristics. Variable frequency characteristics-V/F control of induction motor.

From Rotor side: Static rotor resistance control – Slip power recovery – Static Scherbius drive – Static Kramer Drive – their performance and speed torque characteristics – advantages applications –

problems

## **UNIT – V**

### **Control of Synchronous Motors**

Separate control & self control of synchronous motors – Operation of self controlled synchronous motors by VSI and CSI cycloconverters. Load commutated CSI fed Synchronous Motor – Operation – Waveforms – speed torque characteristics – Advantages – Applications.

#### **Text Books:**

1. G K Dubey , “Fundamentals of Electric Drives”, CRC Press, 2002.
2. M.H.Rashid, “Power Electronic Circuits, Devices and applications”, Pearson Education India; 4<sup>rd</sup> edition, 2017.

#### **Reference Books:**

1. MD Singh and K B Khanchandani , “Power Electronics”, Tata – McGraw-Hill Publishing company,2017.
2. B.K.Bose, “Modern Power Electronics and AC Drives”, Prentice Hall, 2001.
3. Vedam Subramanyam, “Thyristor Control of Electric drives”, Tata McGraw Hill Publilcations, 2017.
4. S K Pillai, “A First course on Electrical Drives”, New Age International(P) Ltd. 3<sup>rd</sup> Editon, 2016.

## UNIT – I

### SYLLABUS/CONTENTS:

#### Part-1 :CONTROL OF DC MOTORS BY SINGLE PHASE CONVERTERS:

- Introduction to Thyristor controlled Drives
- Single Phase Semi and Fully controlled converters connected to D.C separately excited and D.C series motors
- Continuous current operation : output voltage and current waveforms
- Speed and Torque expressions
- Speed – Torque Characteristics
- Problems on Converter fed D.C motors.
- Summary
  - Important conclusions and concepts
  - Important formulae and equations

#### Part-2 : CONTROL OF DC MOTORS BY THREE PHASE CONVERTERS:

- Introduction to Three phase converters
- Three phase semi and fully controlled converters connected to D.C Separately excited and D.C series motors.
- Output voltage and current waveforms
- Speed and Torque expressions
- Speed – Torque characteristics
- Problems
- Summary
  - Important conclusions and concepts
  - Important formulae and equations

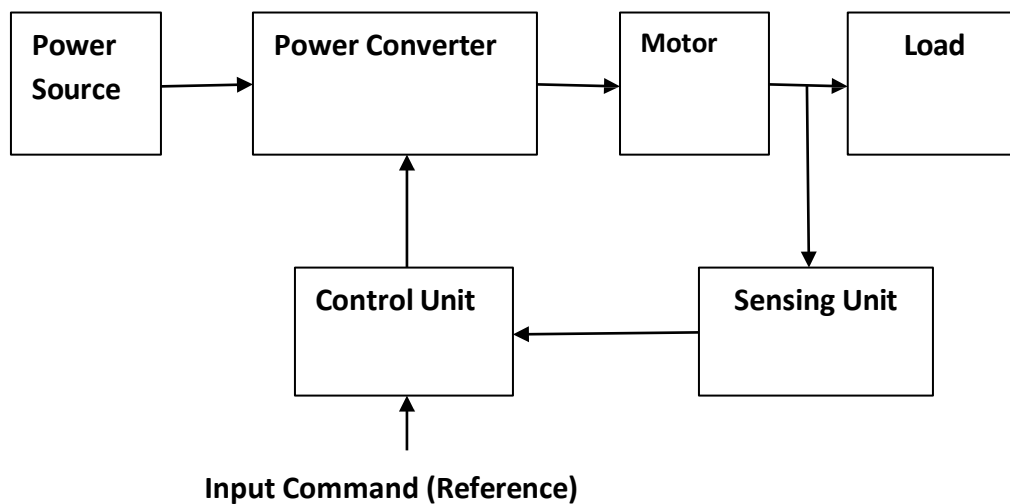


**Introduction to Electrical Drives:**

Motion control is required in large number of industrial and domestic applications like transportation systems, rolling, paper & textile mills, machine tools, fans, pumps, robots, washing machines etc. Systems employed for getting the required motion and their smooth control are called Drives. Drives require prime movers and they can be Diesel or petrol engines, gas or steam turbines, steam engines, hydraulic motors or electric motors. These prime movers deliver the required mechanical energy for getting the motion and its control. Drives employing Electric motors as prime movers and for motion control are called Electric Drives.

Block diagram of an Electrical drive is shown in the figure below.

The load: Can be any one of the systems like pumps, machines etc mentioned above to carry out a specific task. Usually the load requirements are specified in terms of its speed/torque demands. An electrical motor having the torque speed characteristics compatible to that of the load has to be chosen.



**Fig: Block diagram of an Electrical drive**

Power Converter: Performs one or more of the following functions.

- Converts Electrical energy from the source into a form suitable to the motor. Say AC to DC for a DC motor and DC to AC for an Induction motor.
- Controls the flow of power to the motor so as to get the Torque Speed characteristics as required by the load.
- During transient operations such as Starting, Braking, Speed reversal etc limits the currents to permissible levels to avoid conditions such as Voltage dips, Overloads etc.
- Selects the mode of operation of the Motor i.e Motoring or Braking

Control unit/Sensing unit: The control unit controls the operation of the Power converter based on the Input command and the feedback signal continuously obtained from a suitable point (In a closed loop operation) at the load end so as to get the desired load performance. The sensor unit gets the feedback on voltage and current also to operate the motor within its safe operating conditions.

Advantages of Electrical Drives:

- The steady state and dynamic performance can be easily shaped to get the desired load characteristics over a wide range of speeds and torques.
- Efficient Starting /Braking is possible with simple control gear.
- With the rapid development in the field of Power Electronics and availability of high speed/high power devices like SCRs, Power MOSFETs, IGBTs etc., design of Efficient Power Converters to feed power to the electric drives has become simple and easy.
- With the rapid development in the computer's HW & SW, PLCs and Microcontrollers which can easily perform the control unit functions have become easily available.
- Electric motors have high efficiency, low losses, and considerable overloading capability. They have longer life, lower noise and lower maintenance requirements.
- They can operate in all the four quadrants of operation in the Torque/Speed plane. The resulting Electric braking capability gives smooth deceleration and hence gives longer life for the equipment. Similarly Regenerative braking results in considerable energy saving.

- 
- They are powered from electrical energy which can be easily transferred, stored and handled.

Because of the above advantages, in several applications like Diesel locomotives, Ships etc. the mechanical energy already available from a nonelectrical prime mover is first converted into electrical energy by a generator and then An Electric Drive is used as explained above.

Parts of an Electric Drive:

Electrical Motors: most commonly used motors are DC motors – Shunt, Series, Compound etc., AC motors- Squirrel cage & Slip ring induction motors, Special motors like Brushless DC motors, stepper motors etc.

DC motors have a number of disadvantages compared to Induction motors due to the presence of commutator and brushes. Squirrel cage motors are less costly than DC motors of the same rating, highly rugged and simple. In the earlier days because of easy speed control DC motors were used in certain applications. But with the development in Power electronics and the advantages of AC motors AC drives have become more popular in several applications in present days.

Power Converters:

There are several types of power converters depending upon the type of motor used in a given drive. A brief outline of a few important types is given below.

AC to DC converters: They convert single phase/Polyphase AC supply into fixed or variable DC supply using either simple rectifier circuits or controlled rectifiers with devices like thyristors, IGBTs, Power MOSFETs etc. depending upon the application.

AC voltage controllers or AC regulators: They are employed to get a variable AC voltage of the same frequency from a single phase or three phase supply. Some such controllers are Auto transformers, Transformers with various taps and Converters using Power electronics devices.

DC to DC converters: They are used to get variable DC voltage from a fixed DC voltage source using Power electronics devices. Smooth step less variable voltage can be obtained with such converters.

Inverters: They are employed to get variable voltage /variable frequency from DC supply using PWM techniques. The inverters also use the same type of Power electronics devices like MOSFETs,IGBTs,SCRs etc.

Cycloconverters: They convert fixed voltage fixed frequency AC supply into variable voltage variable frequency supply to control AC drives. They are also built using Power electronic devices and by using controllers at lower power level.

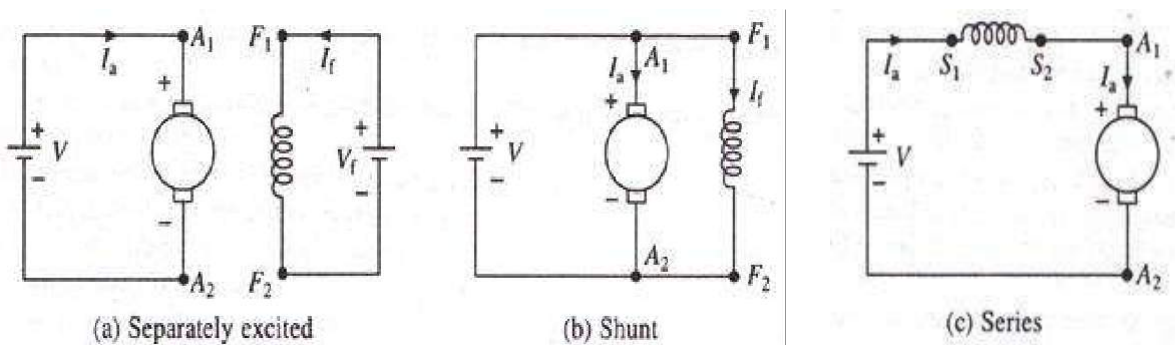
**DC Motor Drives:**

DC drives are widely used in applications requiring adjustable speed, good speed regulation and frequent starting, braking, and reversing. Some important applications are rolling mills, paper mills, mine winders, hoists, machine tools, traction, printing process, textile mills, excavators and cranes. Fractional horsepower DC motors are widely used as servo motors for positioning and tracking.

Although since late sixties, it is being predicted that AC drives would replace DC drives , however even today the variable speed applications are dominated by DC drives because of lower cost, reliability and simple control.

DC motors and their performance:

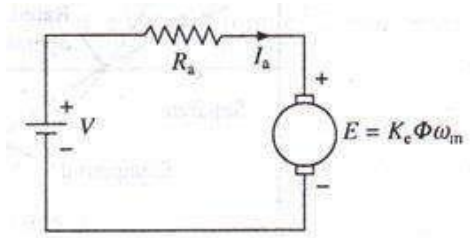
Basic schematic diagrams of DC separately excited, shunt and Series motors are shown in the figure below.



**Fig: Basic Schematic digrams of DC motors**

- a) In a separately excited DC motor the field and armature are connected to separate voltage sources and can be controlled independently.
- b) In a shunt motor the field and the armature are connected to the same source and cannot be controlled independently.
- c) In a series motor the field current and armature current are same and hence the field flux is dependent on armature current.

The Steady state equivalent circuit of a DC motor Armature is shown in the figure below.



**Fig: Steady state equivalent circuit of a DC Motor Armature**

Resistance  $R_a$  is the resistance of the armature circuit. For separately excited and shunt motors it is resistance of the armature winding and for series motors it is the sum of the field winding and armature winding resistances.

The output characteristics of DC motors (Torque/Speed characteristics): They can be obtained from the Motor's Induced voltage and torque equations plus the Kirchhoff's voltage law around the armature circuit and are given below.

- The internal voltage generated in a DC motor is given by:  $E_b = K_a \cdot \Phi \cdot \omega$
- The internal Torque generated in a DC motor is given by:  $T = K_a \cdot \Phi \cdot I_a$
- KVL around the armature circuit is given by :  $E_a = E_b + I_a \cdot R_a$

Where	$\Phi$ =	Flux per pole	....	Webers
	$I_a$ =	Armature current	....	Amperes
	$E_a$ =	Applied terminal Voltage	....	Volts
	$R_a$ =	Armature resistance	....	Ohms
	$\omega$ =	Motor speed	....	Radians/s c
	$E_b$ =	Armature Back EMF	....	Volts
	$K_a$ =	Motor Back EMF/Torque constant		

From the above three equations we get the relation between Torque and speed as:

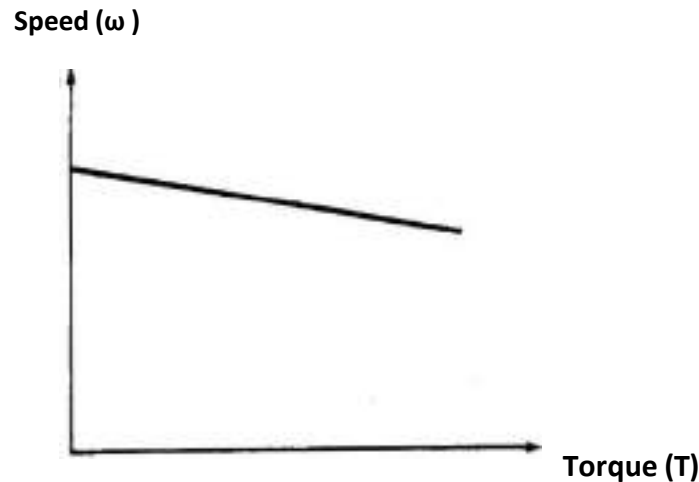
$$\begin{aligned}\omega &= (E_a / K_a \cdot \Phi) - (R_a / K_a \cdot \Phi) \cdot I_a \\ &= (E_a / K_a \cdot \Phi) - [R_a / (K_a \cdot \Phi)^2] \cdot T\end{aligned}$$

### Shunt and Separately excited motors:

In their case with a constant field current the field flux can be assumed to be constant and then  $(K_a \cdot \Phi)$  would be another constant  $K$ . Then the above Torque speed relations would become :

$$\begin{aligned}\omega &= E_a / K - (R_a / K) \cdot I_a \\ &= E_a / K - [R_a / (K)^2] \cdot T\end{aligned}$$

The Speed/ Torque Characteristics of a DC Separately Excited Motor for a rated terminal voltage and full field current are shown in the figure below. It is a drooping straight line.



**Fig: Speed/ Torque Characteristics of a DC Separately Excited Motor**

The no load speed is given by the Applied armature terminal voltage and the field current. Speed falls with increasing load torque. The speed regulation depends on the Armature circuit resistance. The usual drop from no load to full load in the case of a medium sized motor will be around 5%. Separately excited motors are mostly used in applications where good speed regulation and adjustable speed are required.

**Series Motor:** In series motors the field flux  $\Phi$  is dependent on the armature current  $I_a$  and can be assumed to be proportional to the armature current in the unsaturated region of the magnetization characteristic. Then

$$\Phi = K_f \cdot I_a$$

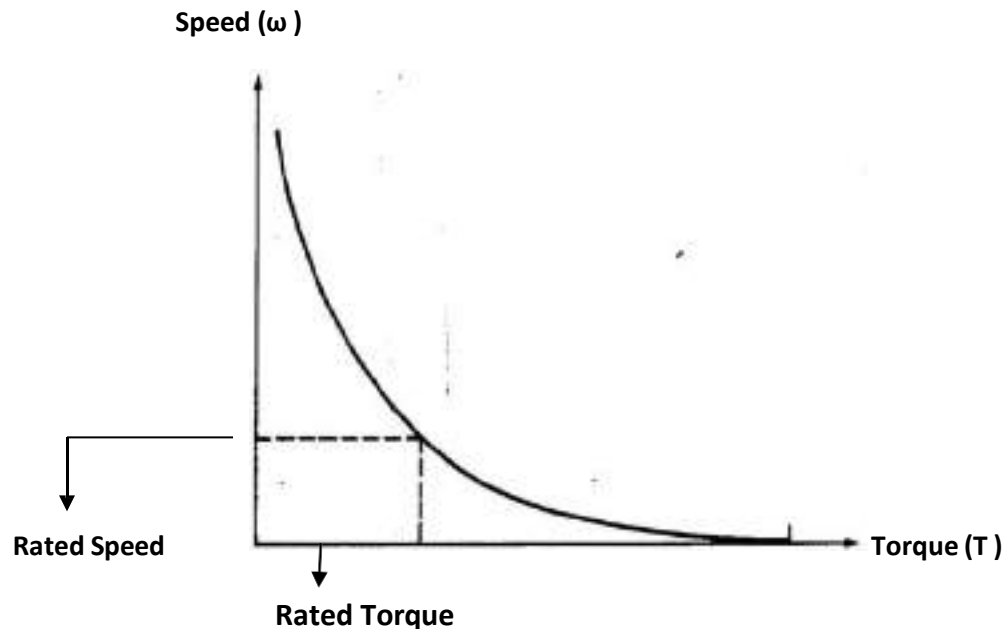
And using this value in the three basic motor relations given earlier we get

$$T = K_a \cdot \Phi \cdot I_a = K_a \cdot K_f \cdot I_a^2 \quad \text{and}$$

$$\omega = E_a / K_a \cdot K_f \cdot I_a - (R_a / K_a \cdot K_f)$$

$$\omega = [E_a / \sqrt{K_{af} \cdot T}] - [R_a / (K_{af})]$$

Where  $R_a$  is now the sum of armature and field winding resistances and  $K_{af} = K_a \cdot K_f$  is the total motor constant. The Speed-Torque characteristics of a DC series motor are shown in the figure below.



**Fig: Speed-Torque characteristics of a DC series motor**

Series motors are suitable for applications requiring high starting torque and heavy overloads. Since Torque is proportional to square of the armature current, for a given increase in load torque the increase in armature current is less in case of series motor as compared to a separately excited motor where torque is proportional to only armature current. Thus during

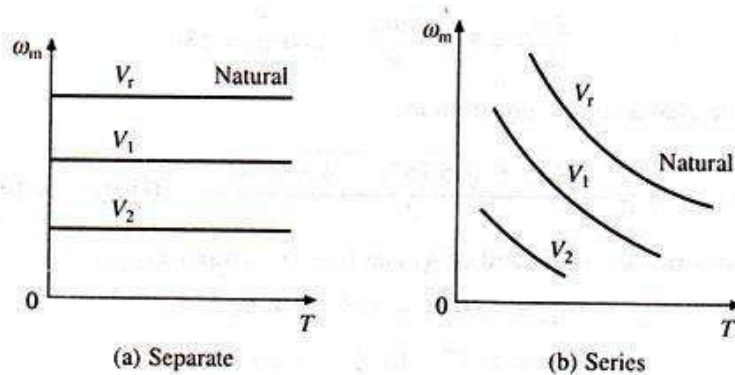
heavy overloads power overload on the source power and thermal overload on the motor are kept limited to reasonable small values. According to the above Speed torque equation, as speed varies inversely to the square root of the Load torque, the motor runs at a large speed at light load. Generally the electrical machines' mechanical strength permits their operation up to about twice their rated speed. Hence the series motors should not be used in such drives where there is a possibility for the torque to drop down to such an extent that the speed exceeds twice the rated speed.

### DC Motor speed control:

There are two basic methods of control

- Armature Voltage Control (AVC) and
- Flux control

Torque speed curves of both SE (separately Excited) motors and series motors using these methods are shown in the figure below.



**Fig: Torque speed curves with AVC :  $V_r$  ( V rated )  $> V_1 > V_2$**



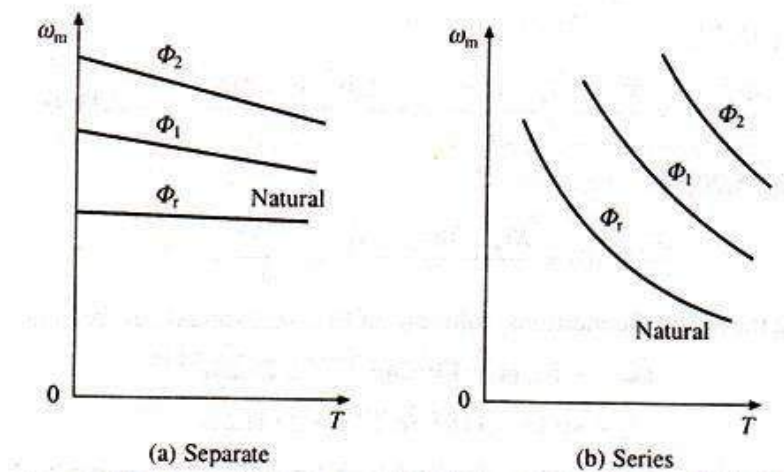
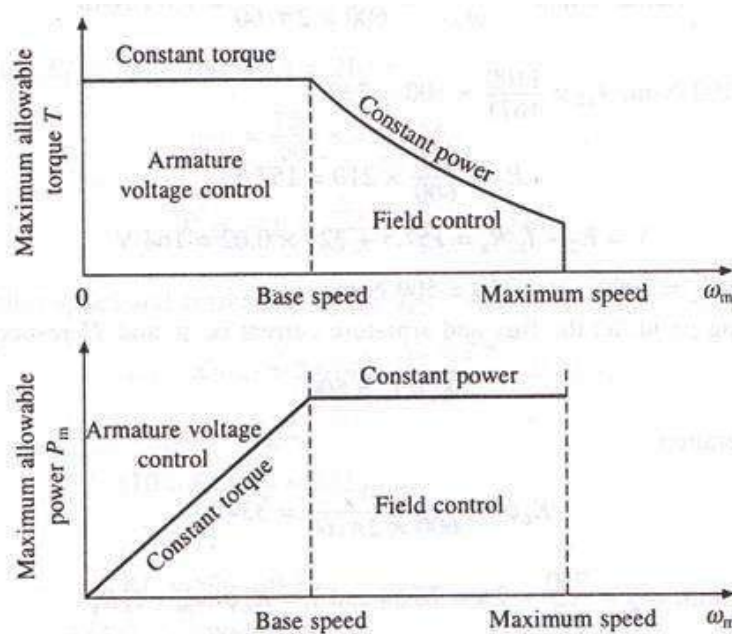


Fig: Torque speed curves with FC :  $\Phi_r$  ( $\Phi$  rated)  $> \Phi_1 > \Phi_2$

#### Important features of DC Motor speed control:

- AVC is preferred because of high efficiency, good transient response, and good speed regulation. But it can provide speed control below Base speed only because armature voltage cannot exceed the rated value.
- For speeds above Base speed Field Flux Control is employed. In a normally designed motor the maximum speed can be twice the rated speed and in specially designed motors it can be up to six times the rated speed.
- AVC is achieved by Single and Three phase Semi & Full converters.
- FC in separately excited motors is obtained by varying the voltage across the field winding and in series motors by varying the number of turns in the field winding or by connecting a diverting resistance across the field winding.
- Due to the maximum torque and power limitations , DC Drives operating
  - With full field, AVC below base speed can deliver a constant maximum torque. This is because in AVC with full field, the Torque is proportional to  $I_a$  and consequently the torque that the motor can deliver has a maximum value.
  - With rated Armature Voltage, Flux control above base speed can deliver a constant maximum power. This is because at rated armature voltage,  $P_m$  is proportional to  $I_a$  and consequently the maximum power that can be developed by the motor has a constant value.

***These limitations are shown in the figure below.***



**Fig: Torque and Power limitations in Combined Armature Voltage and Flux controls**

### Single phase Semi converter drives:

Semi converters are one quadrant converters. i.e. they have one polarity of voltage and current at the DC terminals. The circuit diagram of Semi converter feeding a DC separately excited motor is shown in the figure below. The armature voltage is controlled by a  $1\phi$  semi converter and the field circuit is fed from a separate DC source. The motor current cannot reverse since current cannot flow in the reverse direction in the thyristors. In Semi converters the DC output voltage and current are always positive. Therefore in drive systems using semi converters reverse power flow from motor to AC supply side is not possible. The armature current may be continuous or discontinuous depending on the operating conditions and circuit parameters. The torque speed characteristics would be different in the two modes of conduction. We will limit our study to Continuous conduction mode in this chapter.

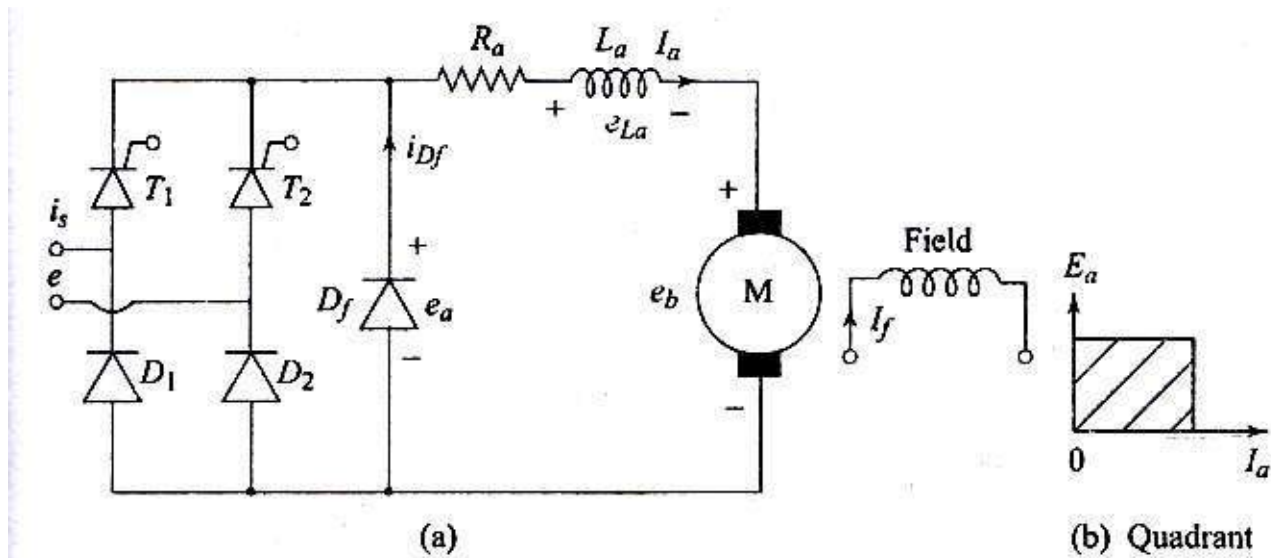
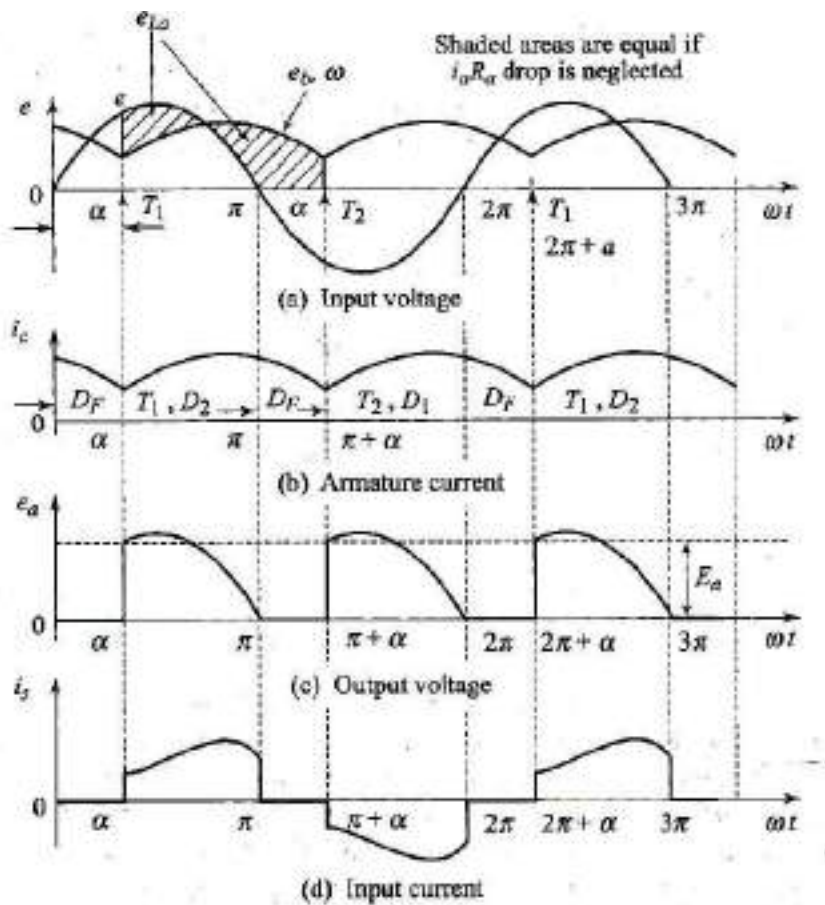


Fig: Single Phase Semi converter feeding a Separately Excited DC Motor

#### Performance of Semi converter in Continuous current operation mode:

The voltage and current waveforms are shown in the figure below for operation in continuous current mode over the whole range of operation. SCR T1 is triggered at a firing angle  $\alpha$  and T2 at the firing angle  $(\pi + \alpha)$ . During the period  $\alpha < \omega t < \pi$  the motor is connected to the input supply through T1 and D2 and the motor terminal voltage  $e_a$  is the same as the input supply voltage 'e'. **Beyond period  $\pi$ ,  $e_a$  tends to reverse as the input voltage changes polarity. This will forward bias the freewheeling diode  $D_f$  and it starts conducting.** The motor current  $i_a$  which was flowing from the supply through T1 is transferred to  $D_f$  ( T1 gets commutated). Therefore during the period  $\pi < \omega t < (\pi + \alpha)$  the motor terminals are shorted through  $D_f$  making  $e_a$  zero.

As explained above, when the thyristor conducts during the period  $\alpha < \omega t < \pi$ , energy from the supply is delivered to the armature circuit. This energy is partially stored in the Inductance, partially stored as kinetic energy in the moving system and partially used up in the load. During the freewheeling period  $\pi < \omega t < (\pi + \alpha)$  energy is recovered from the Inductance and is converted to mechanical form to supplement the Kinetic energy required to run the load. The freewheeling armature current continues to produce the torque in the motor. During this period no energy is feedback to the supply.



**Fig: Voltage and Current waveforms for Continuous current operation in a single Phase semi controlled drive connected to a separately excited DC motor.**

**Torque Speed Characteristics of a Single phase semi converter connected to DC separately excited motor:**

In terms of average voltages, KVL around the motor armature gives

$$E_a(\alpha) = E_b + I_a R_a = K_a \phi \cdot N + I_a R_a$$

Therefore

$$N = [E_a(\alpha) - I_a R_a] / K_a \phi$$

Assuming motor current to be continuous, the motor armature voltage as derived above for the single phase semi converter is given by

$$E_a(\alpha) = (E_m/\pi)(1+\cos\alpha)$$

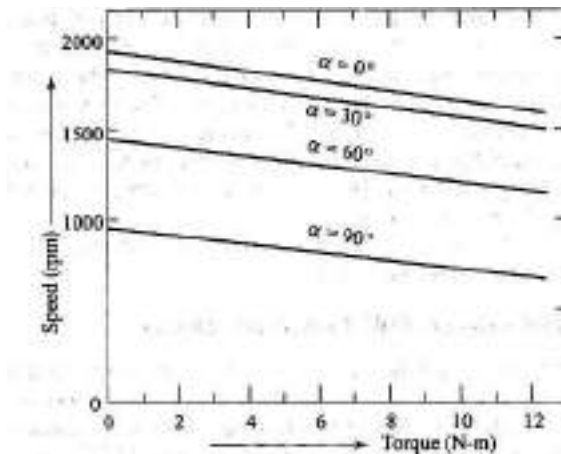
Using this in the above expression for speed N we get

$$N = [(E_m/\pi)(1+\cos\alpha) - I_a R_a] / K_a \phi.$$

$$N = [(E_m/\pi)(1+\cos\alpha) / K_a \phi] - [I_a R_a / K_a \phi]$$

$$N = [(E_m/\pi)(1+\cos\alpha) / K_a \phi] - [T \cdot R_a / (K_a \phi)^2]$$

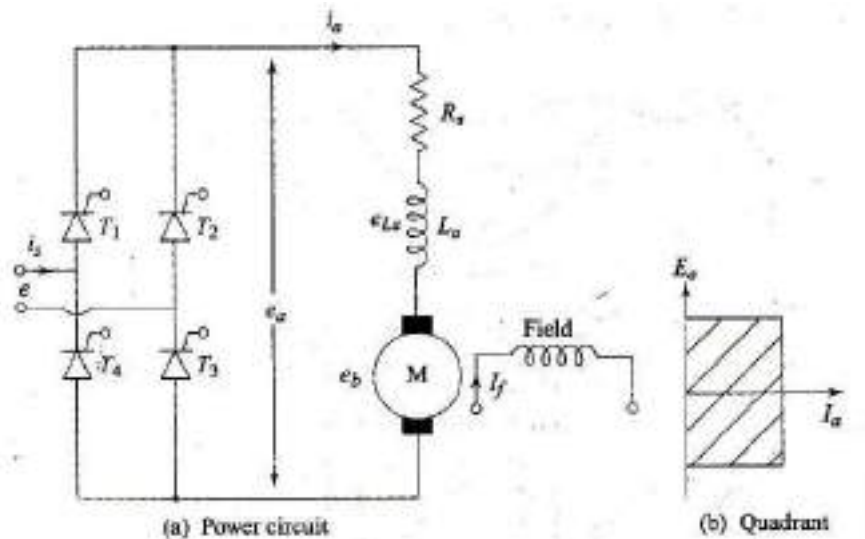
The resulting torque speed characteristics are shown in the figure below.



**Fig: Torque Speed characteristics of a separately excited DC motor Connected to a single Phase semi controlled drive**

### Single phase full converter drive :

A full converter is a two quadrant converter in which the output voltage can be bipolar but the current will be unidirectional since the Thyristors are unidirectional. A full converter feeding a separately excited DC motor is shown in the figure below.

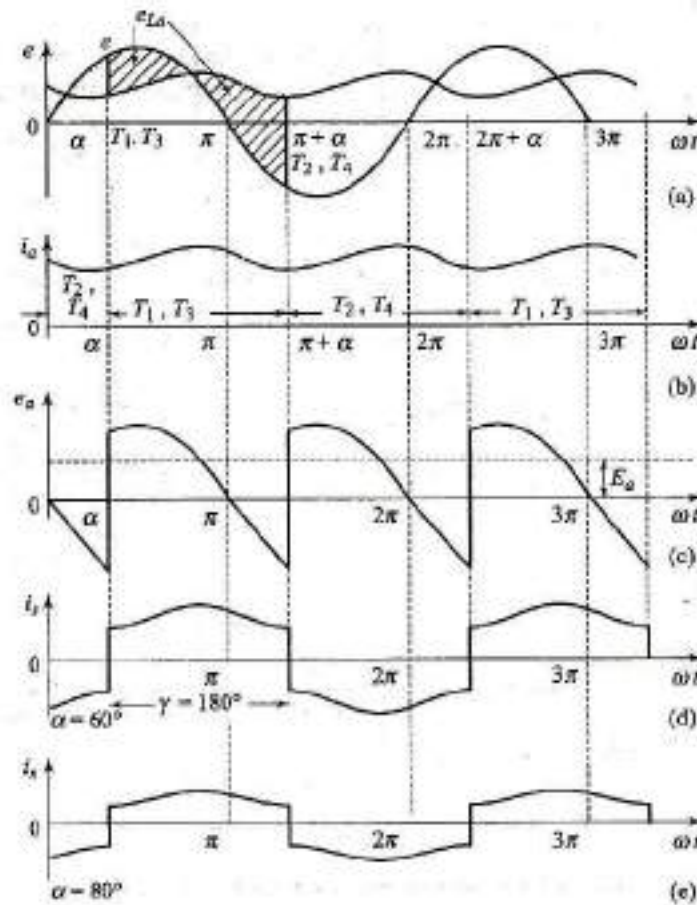


**Fig: Single Phase full converter feeding a separately excited DC motor**

The operation of the Full converter shown in the figure above is explained with the help of the waveforms shown below.

Thyristors T1 and T3 are simultaneously triggered at a firing angle of  $\alpha$  and thyristors T2 and T4 are triggered at firing angle  $(\pi + \alpha)$ . The voltage and current waveforms under continuous current mode are shown in the figure below. Figure shows the input voltage  $e$  and the voltage  $e_{La}$  across the inductance (shaded area). The triggering points of the thyristors are also shown in the figure.

As can be seen from the waveforms, the motor is always connected through the thyristors to the input supply. Thyristors T1 and T3 conduct during the interval  $\alpha < \omega t < (\pi + \alpha)$  and connect the supply to the motor. From  $(\pi + \alpha)$  to  $\alpha$  thyristors T2 and T4 conduct and connect the supply to the motor. At  $(\pi + \alpha)$  when the thyristors T2 and T4 are triggered, immediately the supply voltage which is negative appears across the Thyristors T1 and T3 as reverse bias and switches them off. This is called natural or line commutation. The motor current  $i_a$  which was flowing from the supply through T1 and T3 is now transferred to T2 and T4. During  $\alpha$  to  $\pi$  energy flows from the input supply to the motor (both  $e$  &  $i_s$  and  $e_a$  &  $i_a$  are positive signifying positive power flow). However during the period  $\pi$  to  $(\pi + \alpha)$  some of the motor energy is fed back to the input system. ( $e$  &  $i_s$  and similarly  $e_a$  &  $i_a$  have opposite polarities signifying reverse power flow)



**Fig: Voltage and Current waveforms for Continuous current operation in a single Phase fully controlled drive connected to a separately excited DC motor.**

**Torque Speed Characteristics of a DC separately excited motor connected to a Single phase Full converter:**

Assuming motor current to be continuous, the motor armature voltage as derived above for the single phase full converter is given by:

$$E_a(\alpha) = (2E_m/\pi)(\cos \alpha)$$

In terms of average voltages, KVL around the motor armature gives

$$E_a(\alpha) = E_b + I_a R_a = K_a \phi \cdot N + I_a R_a$$

And therefore the average speed is given by :

$$N = [E_a(\alpha) - I_a R_a] / K_a \phi.$$

In a separately excited DC motor:

$$T = I_a \cdot K_a \cdot \phi.$$

And applying this relationship along with the above value of  $E_a(\alpha)$  for the full converter in the above expression for the speed we get :

$$N = [(2E_m/\pi)(\cos \alpha) - I_a R_a] / K_a \phi.$$

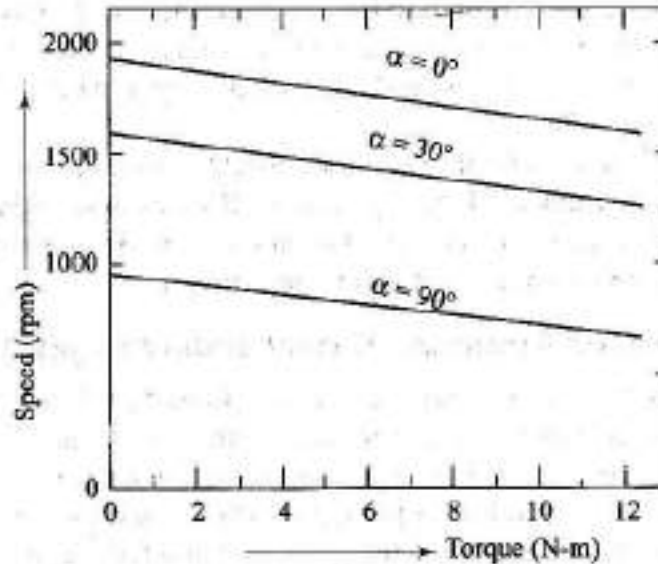
$$N = [(2E_m/\pi)(\cos \alpha) / K_a \phi] - [I_a R_a / K_a \phi]$$

$$N = [(2E_m/\pi)(\cos \alpha) / K_a \phi] - [T \cdot R_a / (K_a \phi)^2]$$

The no-load speed of the motor is given by :

$$N_{NL} = [(2E_m/\pi)(\cos \alpha) / K_a \phi] \text{ where the torque } T = 0$$

The resulting torque speed characteristics are shown in the figure below.



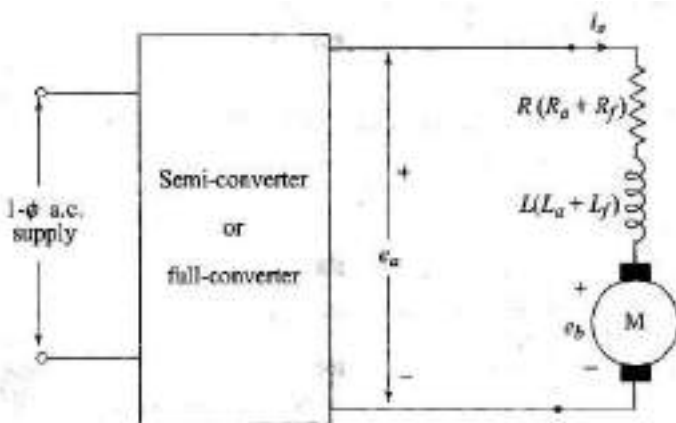
**Fig: Torque Speed characteristics of separately excited DC motor Connected to a single Phase fully controlled drive at different firing angles.**



### Single Phase Converter Drives for DC Series Motors:

Figure below shows the scheme of a basic single phase speed control circuit connected to a DC series motor. As shown the field circuit is connected in series with the armature and the motor terminal voltage is controlled by a semi or a full converter.

- *Series motors are particularly suitable for applications that require a high starting torque such as cranes hoists, elevators, vehicles etc.*
- *Inherently series motors can provide constant power and are therefore particularly suitable for traction drives.*
- *Speed control is very difficult with the series motor because any change in load current will immediately reflect in the speed change and hence for all speed control requirements separately excited motors will be used.*



**Fig: DC Series motor Power circuit**

In the figure the armature resistance  $R_a$  and Inductance  $L_a$  are shown along with the field resistance and inductance. The basic DC series motor equations are given below again for ease of reference

- $E_b = K_a \cdot \Phi \cdot \omega = K_a \cdot K_f \cdot I_a \cdot \omega$  ( since  $\Phi = K_f \cdot I_f = K_f \cdot I_a$  )  
 $= K_{af} \cdot I_a \cdot \omega$  ( where  $K_{af} = K_a \cdot K_f$  )
- $T = K_a \cdot \Phi \cdot I_a = K_a \cdot K_f \cdot I_a^2 = K_{af} \cdot I_a^2$

- $E_a = E_b + I_a \cdot R_a$
- $\omega = E_b / (K_{af} \cdot I_a) \text{ -- } (R_a / K_{af})$
- $\omega = [E_b / \sqrt{(K_{af} \cdot T)}] \text{ -- } [R_a / (K_{af})]$

### Single Phase semi converter drives:

The figure below shows the power circuit of a single phase semi converter controlled DC series motor.

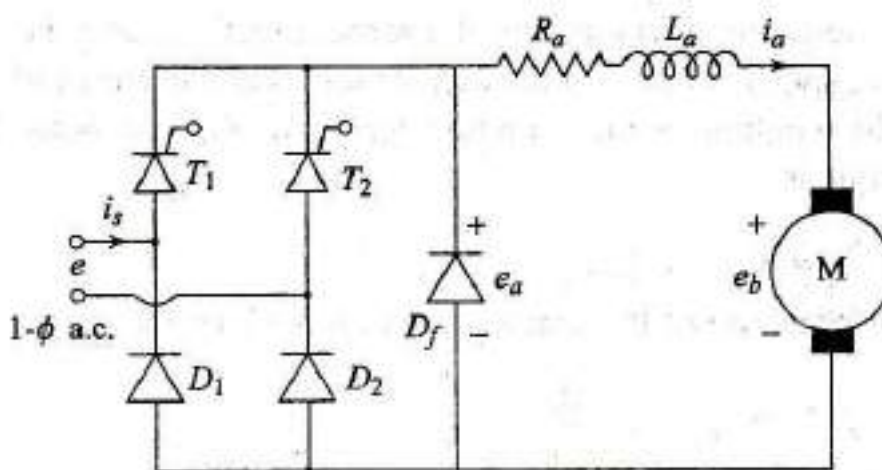


Fig: Power circuit of a Series motor connected to a Semi Controlled converter

Current and voltage waveforms for continuous motor armature current are shown in the figure below. When SCR is triggered at a firing angle  $\alpha$  the current flows during the period  $\alpha$  to  $(\pi + \alpha)$  for continuous conduction.

In separately excited motors a large Back EMF  $E_b$  is always present even when the armature current is absent. This back EMF  $E_b$  tends to oppose the motor current and so the motor current decays rapidly. This leads to discontinuous motor current over a wide range of operations. Whereas in series motors the back EMF is proportional to the armature current and so  $E_b$  decreases as  $I_a$  decreases. So the motor current tends to be continuous over a wide range of operations. Only at high speed and low current is the motor current is likely to become discontinuous.

Like in earlier semi converters Freewheeling diode is connected across the converter output as shown in the figure above. Freewheeling action takes place during the interval  $\pi$  to  $(\pi + \alpha)$  in continuous current operation.

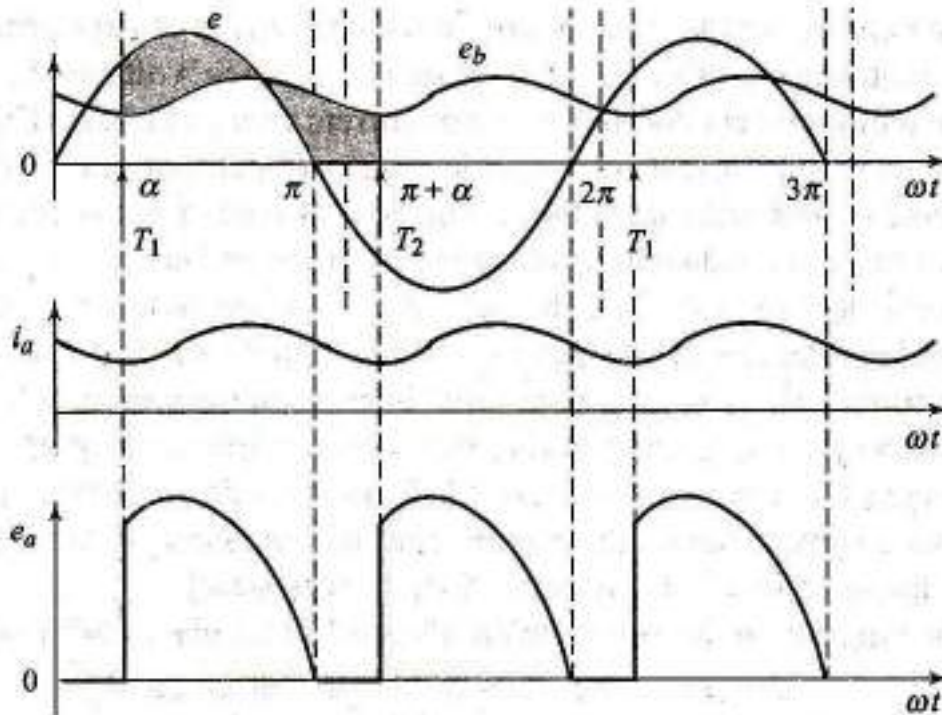


Fig: DC Series motor Semi Converter waveforms in continuous current operation.

In phase controlled converters for Series motors, the current is mostly continuous and the motor terminal voltage can be written as

$$\begin{aligned} E_a &= E_m / \pi (1 + \cos \alpha) = I_a R_a + E_b \\ &= I_a R_a + K_{af} \cdot I_a \cdot \omega \end{aligned}$$

Hence from the above equation the average speed can be written as

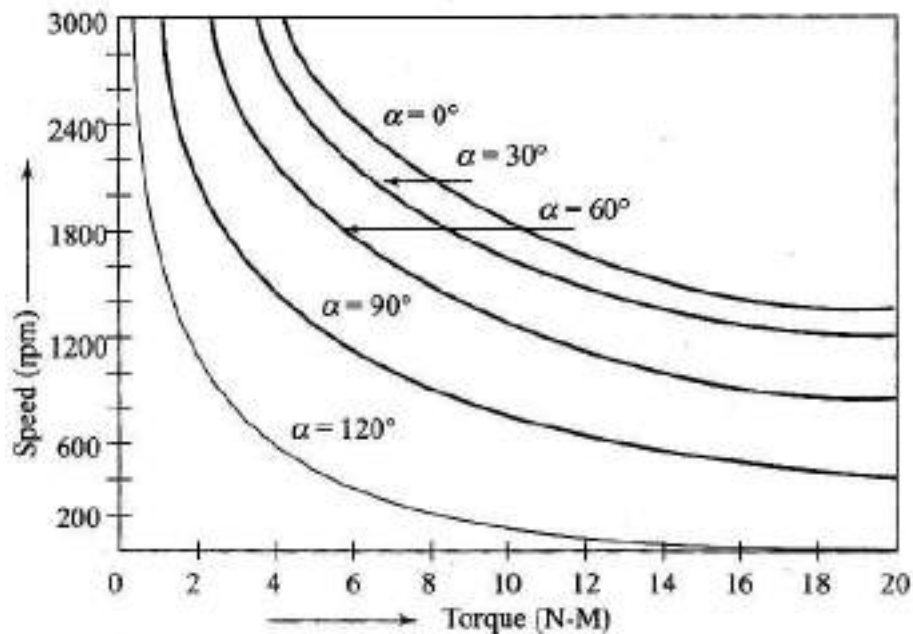
$$N = \left[ \frac{E_m/\pi(1+\cos\alpha)}{K_{af} \cdot I_a} \right] - \left[ \frac{R_a \cdot I_a}{K_{af}} \right]$$

$$N = \left[ \frac{E_m/\pi(1+\cos\alpha)}{\sqrt{K_{af} \cdot T}} \right] - \left[ \frac{R_a}{K_{af}} \right]$$

And the expression for the torque can be rewritten as

$$T = K_{af} \left[ \frac{E_m/\pi(1+\cos\alpha)}{R_a + K_{af} \cdot N} \right]^2$$

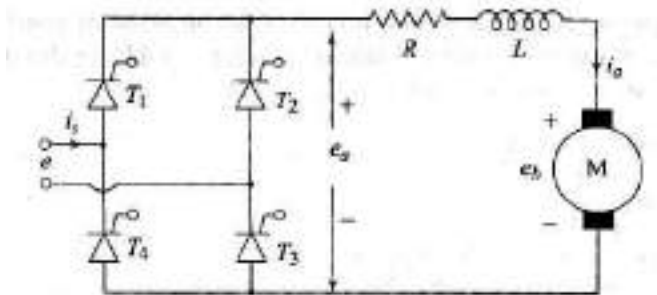
The torque Speed characteristics under the assumption of continuous and ripple free current flow are shown in the figure below for different firing angles  $\alpha$ .



**Fig: Torque Speed Characteristics of a DC Series motor controlled by a Single phase Semi converter**

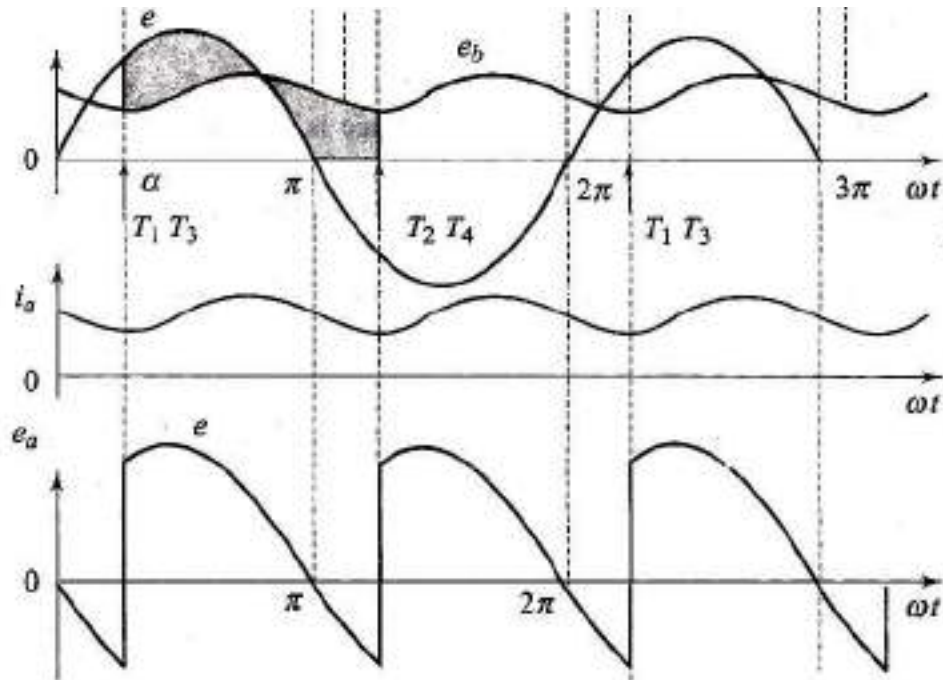
**Single Phase full converter drive:**

The figure below shows the power circuit of a single phase Fully controlled converter connected to a DC series motor.



**Fig: Power circuit of a Series motor connected to a fully controlled converter**

Thyristors  $T_1$  &  $T_3$  are simultaneously triggered at  $\alpha$  and  $T_2$  &  $T_4$  are simultaneously triggered at  $(\pi + \alpha)$ . Current and voltage waveforms for continuous motor armature current are shown in the figure below. When SCR is triggered at a firing angle  $\alpha$  the current flows during the period  $\alpha$  to  $(\pi + \alpha)$  for continuous conduction.



**Fig: DC Series motor Full converter waveforms in continuous current operation.**

The motor terminal voltage can be written as

$$E_a = \frac{2E_m}{\pi} (\cos \alpha) = I_a R_a + E_b$$

$$= I_a R_a + K_{af} \cdot I_a \cdot \omega$$

Hence from the above equation the expression for average speed can be written as

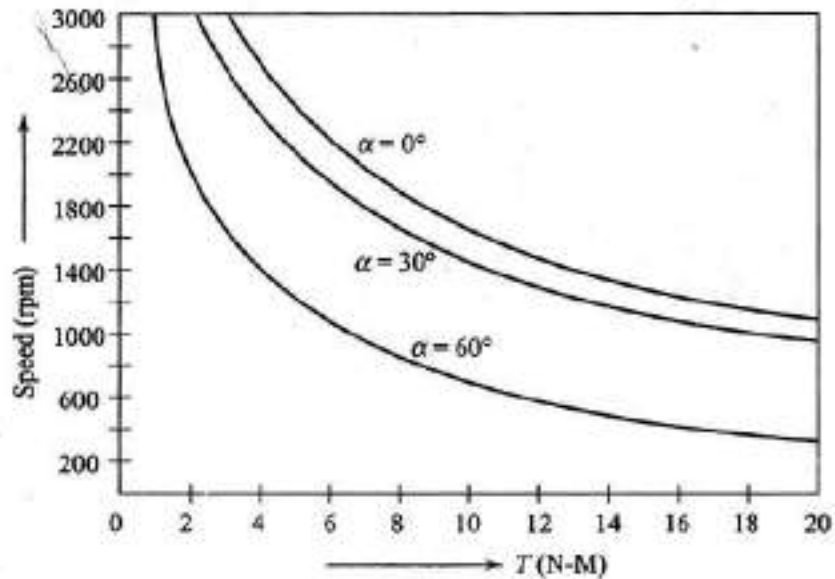
$$\omega = \left[ \frac{(2E_m/\pi)(\cos\alpha)}{(K_{af} \cdot I_a)} \right] - \left[ \frac{R_a \cdot I_a}{K_{af} \cdot I_a} \right]$$

$$\omega = \left[ \frac{(2E_m/\pi)(\cos\alpha)}{K_{af} \cdot I_a} \right] - \left[ \frac{R_a}{K_{af}} \right]$$

And the expression for the torque can be rewritten as

$$T = K_{af} \left[ \frac{(2E_m/\pi)(\cos\alpha)}{R_a + K_{af} \cdot \omega} \right]^2$$

The torque Speed characteristics under the assumption of continuous and ripple free current flow are shown in the figure below for different firing angles  $\alpha$ .



**Fig: Torque Speed characteristics of a Series motor connected to a fully controlled converter**

### Summary:

#### Important conclusions and concepts:

- In single phase converters output ripple frequency is 100 Hz.
- Separately excited motors are mostly used in applications where good speed regulation and adjustable speed are required.
- Series motors are suitable for applications requiring high starting torque and heavy overloads.
- In case of series motors, Since Torque is proportional to square of the armature current, for a given increase in load torque the increase in armature current is less as compared to separately excited motors where torque is proportional to only armature current.
- There are two basic methods of speed control. Armature Voltage Control and Flux Control.
- AVC is used for speeds below base speeds and FC for speeds above base speed.
- Due to the maximum torque and power limitations DC Drives operating

- With full field , AVC below base speed can deliver a maximum constant torque and
- With rated Armature Voltage, Flux control above base speed can deliver a maximum constant power.
- AVC is achieved by Single and Three phase Semi & Full converters.
- FC in separately excited motors is obtained by varying the voltage across the field winding and in series motors by varying the number of turns in the field winding or by connecting a diverting resistance across the field winding.

### Important formulae and equations:

- *The basic DC motor equations :*
  - The internal voltage generated in a DC motor is given by:  $E = K_a \cdot \Phi \cdot \omega$
  - The internal Torque generated in a DC motor is given by:  $T = K_a \cdot \Phi \cdot I_a$
  - KVL around the armature circuit is given by :  $E_a = E + I_a \cdot R_a$

- *Torque speed relations in semi converter:*

- DC separately excited motor:

$$N = [(E_m/\pi)(1+\cos \alpha) / K_a\Phi] - [T \cdot R_a / (K_a\Phi)^2]$$

- DC series motor :

$$N = [(E_m/\pi)(1+\cos\alpha)/\sqrt{(K_{af} \cdot T)}] - [(R_a/ K_{af})]$$

$$T = K_{af} [(E_m/\pi)(1+\cos\alpha)/(R_a + K_{af} \cdot N)]^2$$

- *Torque speed relations in Full converter:*

- DC separately excited motor:

$$N = [(2E_m/\pi)(\cos \alpha) / K_a\Phi] - [T \cdot R_a / (K_a\Phi)^2]$$

- DC series Motor :

$$N = [(2E_m/\pi)(\cos\alpha)/\sqrt{(K_{af} \cdot T)}] - [(R_a/ K_{af})]$$

$$T = K_{af} [(2E_m/\pi)(\cos\alpha)/(R_a + K_{af} \cdot \omega)]^2$$



## UNIT-I Part 2

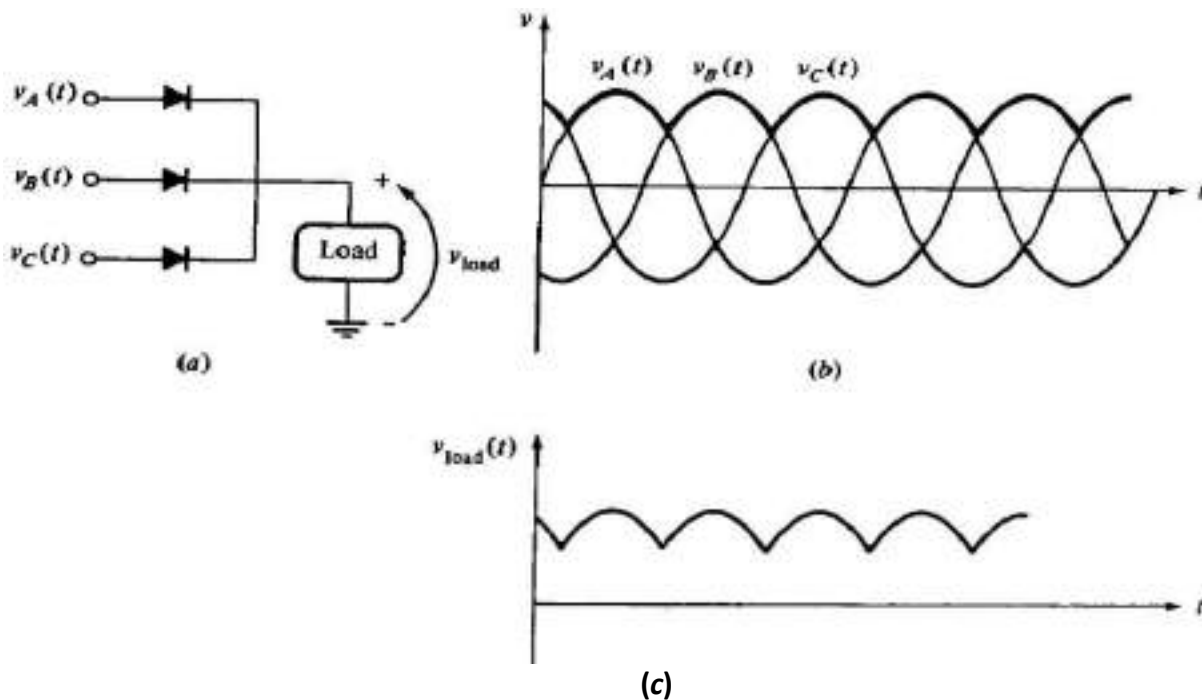
### CONTROL OF DC MOTORS BY THREE PHASE CONVERTERS

#### SYLLABUS/CONTENTS:

- Introduction to Three phase converters
- Three phase semi and fully controlled converters connected to D.C Separately excited and D.C series motors.
- Output voltage and current waveforms
- Speed and Torque expressions
- Speed – Torque characteristics
- Problems
- Summary
  - Important conclusions and concepts
  - Important formulae and equations

#### Introduction to Three Phase Converters:

#### Three Phase Half Wave Rectifier:



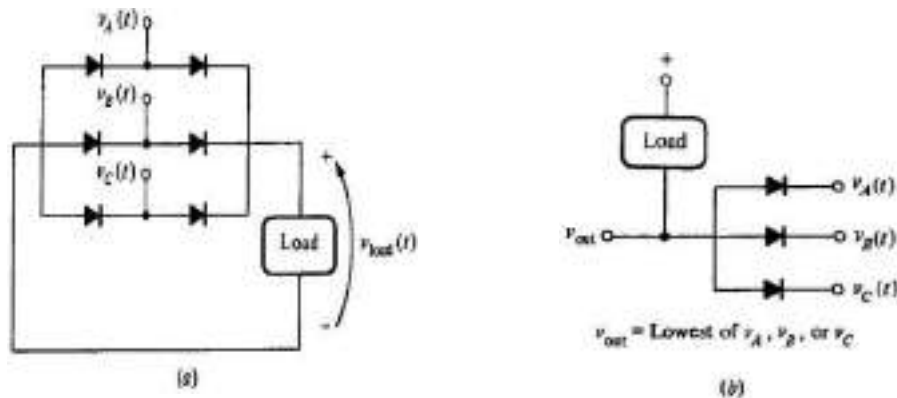
**Fig: (a) Three Phase half wave rectifier circuit (b) Three Phase input voltages to the circuit (c) Output Voltage**

In the HW circuit shown in the fig (a) above the effect of having all the three diode cathodes connected to a common point and then connecting to the Load is that at any instant of time, the **Diode with the highest Input voltage applied to it will conduct** and the other diodes will be reverse biased. The applied three phase voltages are shown in fig (b) and the resulting output voltage across the load is shown in fig (c). It can be seen that the **OP voltage is just the highest of the three input phase voltages at any instant of time**. It can be seen that the ripple frequency in this output is 150 Hz, which is larger than the 100 Hz, ripple frequency in a Single Phase FW rectifier.

### Three Phase Full Wave Rectifier:

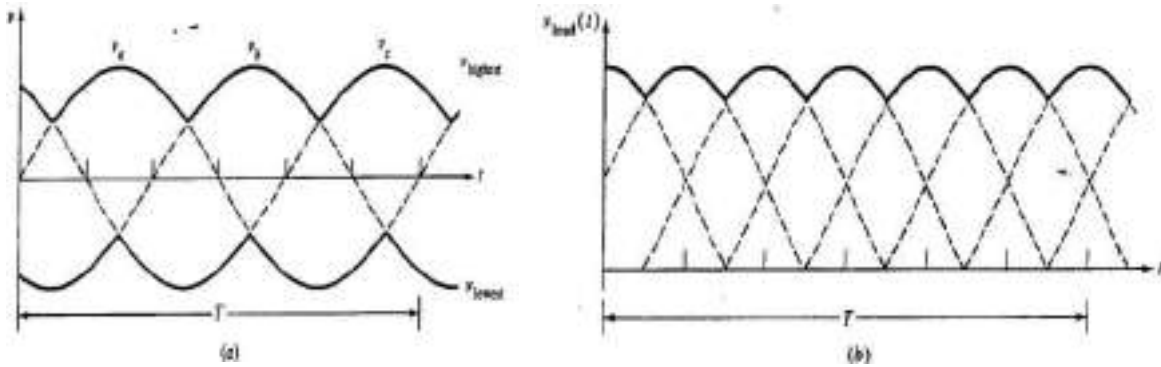
The FW rectifier circuit shown in the fig below consists of basically two parts. One part is just the same as the HW Rectifier and connects the highest of the three input phase voltages to the load. The other part consists of three diodes connected such that their anodes are connected to a common point and then connected to the other end of the load. Their cathodes are connected to the anodes of the first set and to the three phase voltages. This arrangement results in connecting the **lowest of the input voltages to the other end of the load** at any instant of time. **Therefore a Three Phase FWR always connects the highest of the three inputs to one end of the load and the lowest of the three inputs to the other end of the load.**

The OP of a Three Phase FWR is much smoother than a HWR and the ripple frequency is 300 Hz.



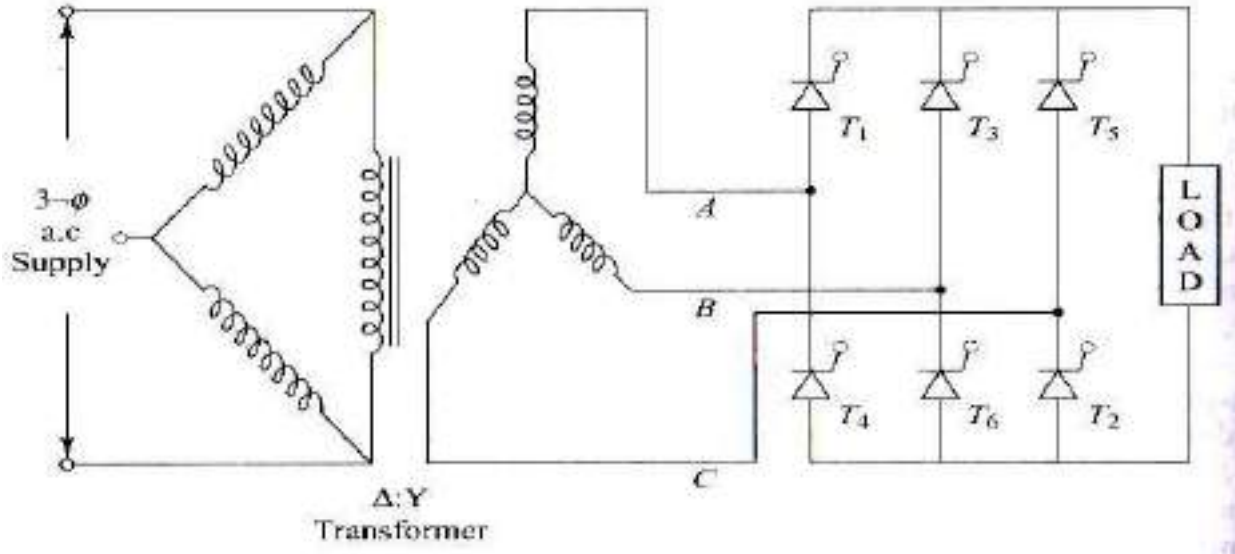
**Fig: (a) A TPFWR circuit (b) This circuit places the lowest of the three IPs on the OP**

The output from a three phase FWR is shown in the figure below.



**Fig: (a) Highest and lowest voltages in a TPFWR (b) The resulting OP voltage**

**Three Phase fully controlled converter connected to a load:** Is shown in the figure bellow. The load can be a simple resistive load or a resistive load combined with an Inductive load.



**Fig: Three Phase Full converter**

The operation of this circuit is first explained for a *Resistive* load with the help of the following important points and with voltage waveforms shown below which are common for both types of loads. Subsequently the operation of the circuit is explained for an *Inductive* load with additional points and separate waveforms (which are again common for  $\alpha = 0^\circ, 30^\circ$  and  $60^\circ$ )

#### Important points:

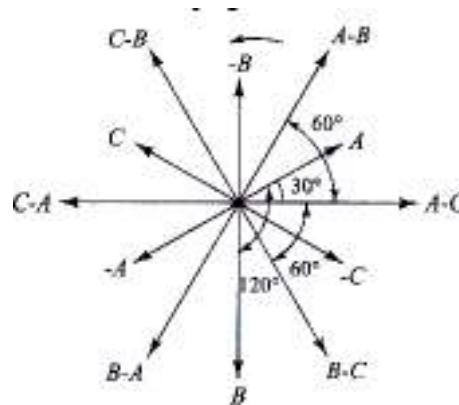
- Thyristors are fired in the sequence of their numbers T1, T2, T3, T4, T5 and T6 with a phase difference of 60 Degrees.
- Thyristors consist of two groups. Positive (Top) group with odd numbered Thyristors T1, T3 & T5 and Negative (Bottom) group with even numbered Thyristors T2, T4 & T6.
- Each thyristor conducts for a duration of 120 degrees and two thyristors conduct at a time one from the Positive group and the other from the Negative group , applying respective line voltage to the motor.
- At any given instant of time, thyristors conduct in pairs and there are six such pairs. They are :  
(T6, T1), (T1, T2), (T2, T3), (T3, T4), (T4, T5) and (T5, T6).
- Each SCR conducts in two consecutive pairs.

- Transfer of current takes place from an outgoing to an incoming thyristor when the respective line voltage is of such a polarity that it not only forward biases the incoming thyristor but it also leads to reverse biasing of the outgoing thyristor when the incoming thyristor turns on. In other words incoming thyristor commutates the outgoing thyristor. i.e T1 commutates T5, T2 commutates T6, T3 commutates T1 and so on.
- The table below gives the details of conducting thyristor pairs, Incoming and outgoing thyristors and the corresponding Line voltages applied across the load.

**Table: Firing sequence of SCRs in the 3  $\phi$  full converter**

S.No.	$\omega t$	Incoming SCR	Conducting pair	Outgoing SCR	Line voltage across the load
1.	$30^\circ + \alpha$	$T_1$	$(T_5, T_1)$	$T_5$	$E_{AB}$
2.	$90^\circ + \alpha$	$T_2$	$(T_6, T_2)$	$T_6$	$E_{BC}$
3.	$150^\circ + \alpha$	$T_3$	$(T_1, T_3)$	$T_1$	$E_{CA}$
4.	$210^\circ + \alpha$	$T_4$	$(T_2, T_4)$	$T_2$	$E_{BA}$
5.	$270^\circ + \alpha$	$T_5$	$(T_3, T_5)$	$T_3$	$E_{CB}$
6.	$330^\circ + \alpha$	$T_6$	$(T_4, T_6)$	$T_4$	$E_{AC}$

- The vector diagram of the three Phase voltages (w.r.to Neutral) and the six line to line voltages are shown in the figure below.

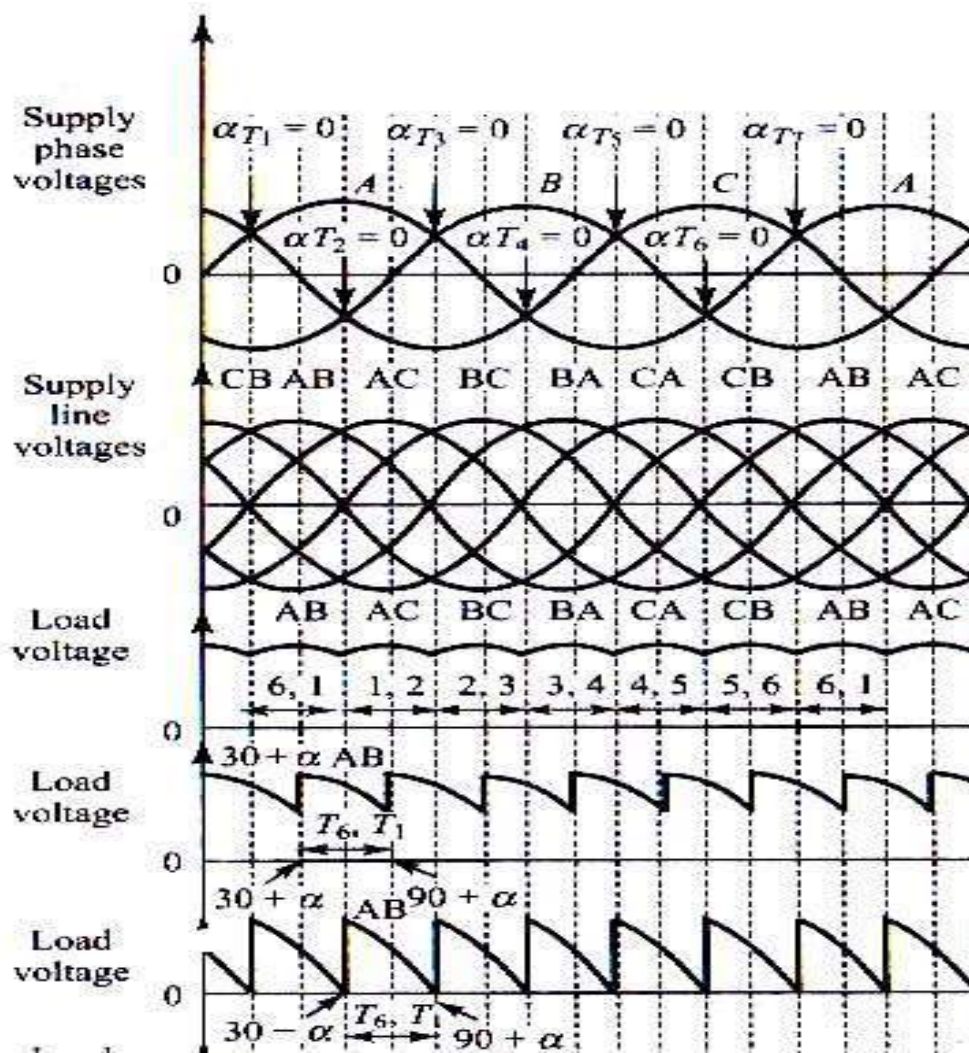


**Fig: Phase sequence and Phase relationships between Phase and line voltages**

- The Phase and Amplitudes of the three phase voltages and the six line to line voltages are given in the table below.

**Table: Phase/ Amplitudes of the three phase voltages and the six line voltages**

$$\begin{array}{ll}
 E_{AN} = E_m \sin(\omega t) & E_{BC} = \sqrt{3} E_m \sin(\omega t - 90^\circ) \\
 E_{BN} = E_m \sin(\omega t - 120^\circ) & E_{BA} = \sqrt{3} E_m \sin(\omega t - 150^\circ) \\
 E_{CN} = E_m \sin(\omega t + 120^\circ) & E_{CA} = \sqrt{3} E_m \sin(\omega t + 150^\circ) \\
 E_{AB} = \sqrt{3} E_m \sin(\omega t + 30^\circ) & E_{CB} = \sqrt{3} E_m \sin(\omega t + 90^\circ) \\
 E_{AC} = \sqrt{3} E_m \sin(\omega t - 30^\circ) &
 \end{array}$$



**Fig: Voltage waveforms of a fully controlled 3  $\phi$  converter with resistive load for firing angles  $\alpha = 0^\circ, 30^\circ$  and  $60^\circ$**

**Inductive load:**

The operation of the 3 $\phi$  converter with an inductive load is explained with the help of the following important points and then with the waveforms shown subsequently.

**Important points:**

- The waveforms are similar to those of the R load for firing angles  $\alpha = 0^\circ, 30^\circ$  and  $60^\circ$
- For  $\alpha > 60^\circ$  the waveforms are different. The voltages go negative due to the inductive load. The previous SCR pair continues to conduct till the next in the sequence is

triggered. For e.g. SCRs T6 and T1 continue to conduct up to  $(90 + \alpha)$  when T2 is triggered. When T2 is triggered it commutates T6 and then the pair (T1,T2) will continue.

- For  $\alpha = 90^\circ$  the area under the positive & the negative cycles are equal and the average voltage is zero.
- For  $\alpha < 90^\circ$  the average voltage is positive and for  $\alpha > 90^\circ$  the average voltage is negative.
- The maximum value of  $\alpha$  is  $180^\circ$
- The output voltage is always a six pulse stream with a ripple frequency of 300 Hz irrespective of the firing angle  $\alpha$ .

### **Expression for the Average output voltage:**

By observing the waveforms of the output voltage and their symmetry we can write:

$$\begin{aligned}
 \text{Average output voltage, } E_{dc} &= 6 \times \frac{1}{2\pi} \int_{30+\alpha}^{90+\alpha} E_{R_1(\omega t)} d\omega t \\
 &= \frac{3}{\pi} \int_{30+\alpha}^{90+\alpha} \sqrt{3} E_m \sin(\omega t + 30) d\omega t = \frac{3}{\pi} \int_{60+\alpha}^{120+\alpha} \sqrt{3} E_m \sin(\omega t) d\omega t \\
 &= \frac{3\sqrt{3} E_m}{\pi} [\cos(\omega t)]_{120+\alpha}^{60+\alpha} = \frac{3\sqrt{3}}{\pi} E_m [\cos(60 + \alpha) - \cos(120 + \alpha)] \\
 E_{dc} &= \frac{3\sqrt{3} E_m}{\pi} \cos \alpha \text{ for } 0 \leq \alpha \leq 180^\circ
 \end{aligned}$$

Where  $E_m$  is the peak value of the phase to neutral voltage.

As could be seen from the waveforms:

- As the firing angle  $\alpha$  changes from  $0$  to  $90^\circ$  the output load voltage varies from maximum to zero and the converter is working in **Rectifier mode**.
- For firing angles of  $\alpha$  from  $90^\circ$  to  $180^\circ$  the voltage varies from zero to negative maximum voltage and the converter is working in **Inverter mode**.



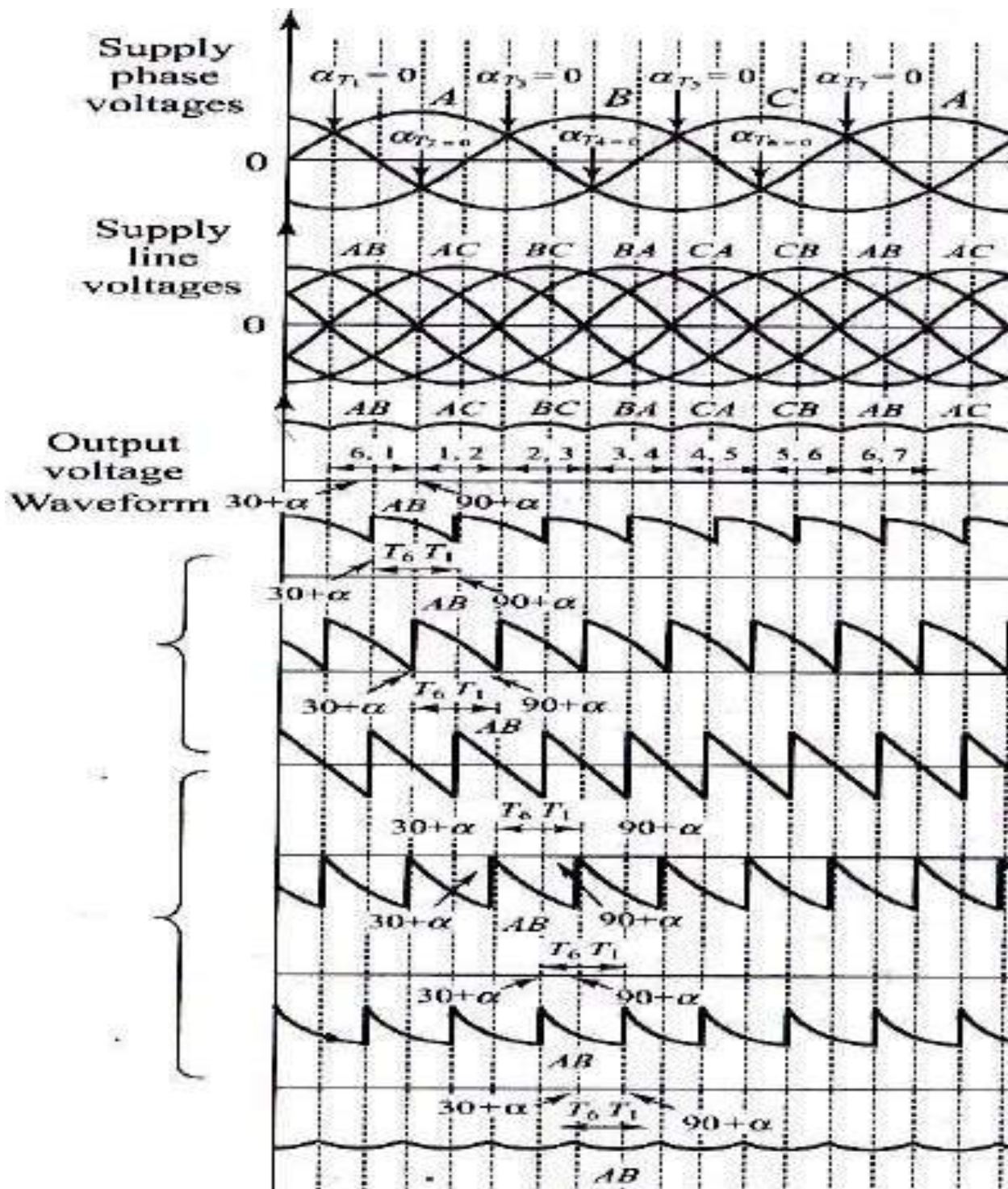
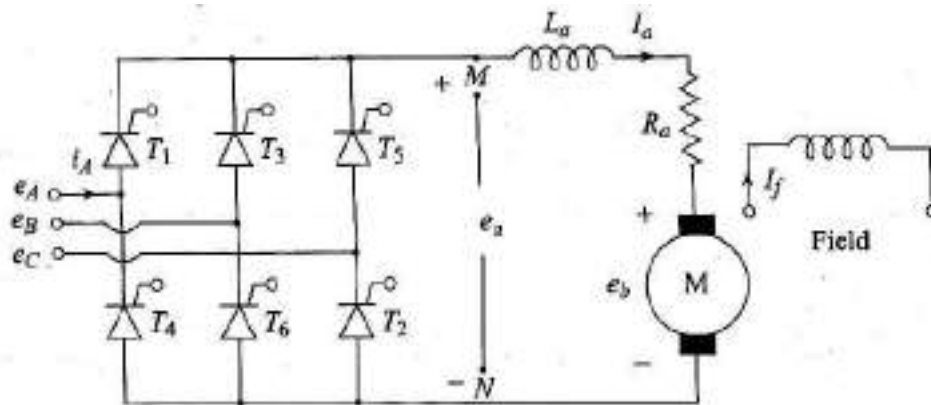


Fig: Voltage waveforms of a Fully controlled 3  $\phi$  converter with Inductive load for firing angles  $\alpha = 0^\circ, 30^\circ, 60^\circ, 90^\circ, 120^\circ, 150^\circ$  and  $180^\circ$

### Three Phase Full converter drive connected to a DC separately excited DC motor:

Figure below shows a three phase Full converter drive circuit connected to a DC separately excited DC motor. It is a two quadrant drive without any field reversal and is limited to applications in the range of 100-150 HP.



**Fig: Three Phase full converter connected to a DC separately excited motor.**

The voltage and current waveforms in this converter for  $\alpha = 60^\circ$  &  $90^\circ$  are shown in the figure below. The instants of firing the thyristors is marked for  $\alpha = 60^\circ$  and shown for a clear understanding. The ripple in the output voltage is six pulses per cycle. Since there are six thyristors in the circuit, they are fired at a faster rate (once in  $60^\circ$ ) and the motor current is mostly continuous. Therefore the filtering requirement is less than that in the semi converter system. The operation is explained for the marked firing angle of  $\alpha = 60^\circ$

Thyristor T1 turns on at  $\omega t = (30^\circ + \alpha)$ . Prior to this SCR T6 was switched ON. Therefore during the interval  $\omega t = (30^\circ + \alpha)$  to  $\omega t = (30^\circ + \alpha + 60^\circ)$ , thyristors T1 and T6 conduct and the Voltage  $e_{AB}$  gets applied to the motor terminals. Thyristor T2 gets triggered at  $\omega t = (30^\circ + \alpha + 60^\circ)$  and immediately SCR T6 gets reverse biased and thus gets switched off. The current flow changes from T6 to T2 and so the voltage  $e_{AC}$  now gets applied to the motor terminals. This process repeats for every  $60^\circ$  whenever a new thyristor in the sequence gets triggered. The thyristors are numbered in the sequence in which they are triggered.

Applying the same logic the waveform for  $\alpha = 90^\circ$  is worked out and shown. It can be seen the instantaneous voltages that get applied to the motor become negative for half the period.

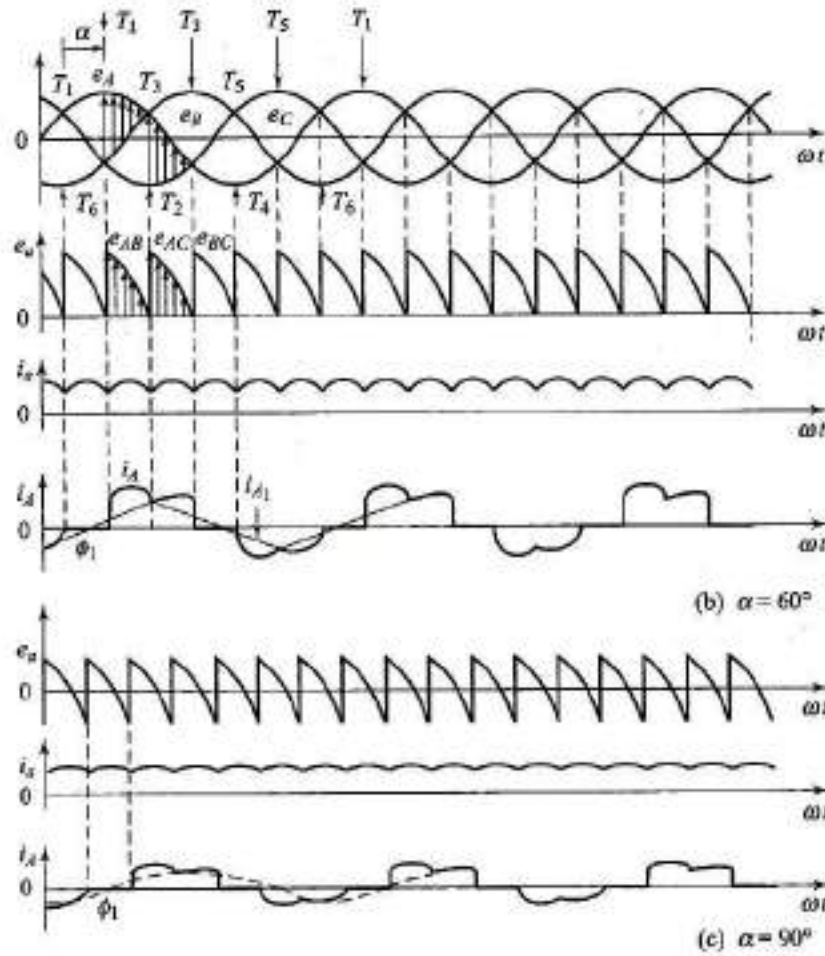


Fig: Three Phase Full Converter Drive Voltage and current waveforms for  $\alpha = 60^\circ$  &  $90^\circ$

**Torque Speed relationships with Full converter connected to a DC separately excited motor:**

Assuming motor current to be continuous, the motor armature voltage as derived above for the full converter is given by:

$$E_a(\alpha) = (3\sqrt{3} E_m / \pi) (\cos \alpha)$$

In terms of average voltages, KVL around the motor armature gives

$$E_a(\alpha) = E_b + I_a R_a = K_a \phi \cdot N + I_a R_a$$

And therefore the average speed is given by :

$$N = [ E_a(\alpha) - I_a R_a ] / K_a \phi.$$

In a separately excited DC motor:

$$T = I_a \cdot K_a \cdot \phi.$$

And applying this relationship along with the value of  $E_a(\alpha)$  for the full converter in the above expression for the speed we get :

$$N = [(3\sqrt{3} E_m/\pi)(\cos \alpha) - I_a R_a] / K_a \phi.$$

$$N = [(3\sqrt{3} E_m/\pi)(\cos \alpha) / K_a \phi] - [I_a R_a / K_a \phi]$$

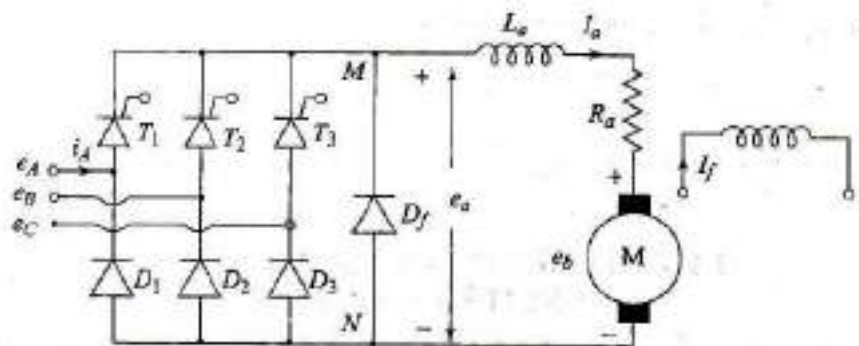
$$N = [(3\sqrt{3} E_m/\pi)(\cos \alpha) / K_a \phi] - [T.R_a / (K_a \phi)^2]$$

The first term in the above equation for the Speed gives the No-load speed (  $T = 0$  ) which therefore depends on  $E_a(\alpha)$ .

*As could be seen the relationship is identical to that of a single phase full converter connected to a DC separately excited motor we have seen earlier( except that the amplitude of  $E_a(\alpha)$  is different)and so the torque speed characteristics are identical (Same curves can be redrawn here )*

**Three Phase Semi Converter drive connected to a DC separately excited motor:**

Figure below shows the power circuit of a three Phase Semiconductor drive connected to a DC separately excited motor. It consists of three SCRs, three diodes and an additional freewheeling diode. It is a one quadrant drive with field reversal capability and is usually limited to applications in the range of 15-150 HP. The field converter can also be a single phase or three phase semi converter.



**Fig: Three Phase Semiconductor drive connected to a DC separately excited motor**

The voltage waveforms in this converter are shown in the figure below for firing angles  $\alpha = 0^\circ, 30^\circ, 60^\circ, 90^\circ$ . The operation of this converter can be explained with the help of the waveforms shown below and the following important points.

- Since there are only three SCRs, they fire at 120° interval ( It may be recalled that this interval was 180° for single-phase full converters and was 60° for three phase full converters)
- Though SCRs get forward biased when their respective phase voltages are positive maximum, they conduct only when they are fired. Hence line voltages  $E_{AB}, E_{BC}$  and  $E_{CA}$

get applied to the load when the corresponding SCRs are triggered. ( for  $\alpha = 0^\circ$  to  $\alpha < 60^\circ$ )

- Diodes start conducting as soon as they are forward biased. And the diodes which get lowest phase voltage get forward biased. Hence line voltages  $E_{AC}, E_{BA}$  and  $E_{CB}$  get applied to the load when the corresponding diodes are forward biased.
- Applying the above basic principles the line voltages that get applied to the load are sketched directly from the six line voltages for firing angles  $\alpha = 30^\circ, 60^\circ$  and  $90^\circ$ .
- It can be seen that all the six Line voltages get applied in the sequence  $E_{AB}, E_{AC}, E_{BC}, E_{BA}, E_{CA}$  and  $E_{CB}$  for ( $\alpha = 0^\circ$  to  $\alpha < 60^\circ$ ) and for ( for  $\alpha > 60^\circ$ ) only three line voltages  $E_{AC}, E_{BA}$  and  $E_{CB}$  get applied to the load.
- The table below shows the pair of conducting devices in sequence and the corresponding line voltages that get applied to the load for ( $\alpha = 0^\circ$  to  $\alpha < 60^\circ$ )

S.No.	Conducting Line Voltages	Conducting Devices
(i)	$E_{AB}$	$(D_6, T_1)$
(ii)	$E_{AC}$	$(T_1, D_2)$
(iii)	$E_{BC}$	$(D_2, T_3)$
(iv)	$E_{BA}$	$(T_3, D_4)$
(v)	$E_{CA}$	$(D_4, T_5)$
(vi)	$E_{CB}$	$(T_5, D_6)$

- For  $\alpha = 0^\circ$  the output voltage waveform is a six pulse stream.
- $\alpha \geq 30^\circ$  the output is only a three pulse stream and hence this converter is also called a three pulse converter.
- The output voltage goes to zero after every pulse after  $\alpha = 60^\circ$  and when  $\alpha > 60^\circ$  it remains at zero for a finite time.
- As can be seen from the waveforms, the output voltage waveforms pulse width is 120° when  $\alpha < 60^\circ$  and when  $\alpha > 60^\circ$  it is  $(180^\circ - \alpha)$

**Expression for the average output voltage:** As could be seen from the above waveforms the nature of waveform is different for  $\alpha < 60^\circ$  and when  $\alpha > 60^\circ$ . The expressions for output voltage are derived below for both the cases.

**Case-I**  $\alpha \leq 60^\circ$ .

The average output voltage is given by

$$E_{dc} = 3 \times \frac{1}{2\pi} \left[ \int_{30+\alpha}^{90} E_{AB}(\omega t) d\omega t + \int_{90}^{150+\alpha} E_{AC}(\omega t) d\omega t \right]$$

Substituting the value of  $E_{AB}(\omega t)$  and  $E_{AC}(\omega t)$  from Eq. (6.48), we get

$$E_{dc} = \frac{3}{2\pi} \left[ \int_{30+\alpha}^{90} \sqrt{3} E_m \sin(\omega t + 30) d\omega t + \int_{90}^{150+\alpha} \sqrt{3} E_m \sin(\omega t - 30) d\omega t \right]$$

$$E_{dc} = \frac{3\sqrt{3} E_m}{2\pi} \left[ (\cos(\omega t + 30))_{90}^{30+\alpha} + (\cos(\omega t - 30))_{150+\alpha}^{90} \right]$$

$$= \frac{3\sqrt{3} E_m}{2\pi} [\cos(60 + \alpha) - \cos(120) + \cos(60) - \cos(120 + \alpha)]$$

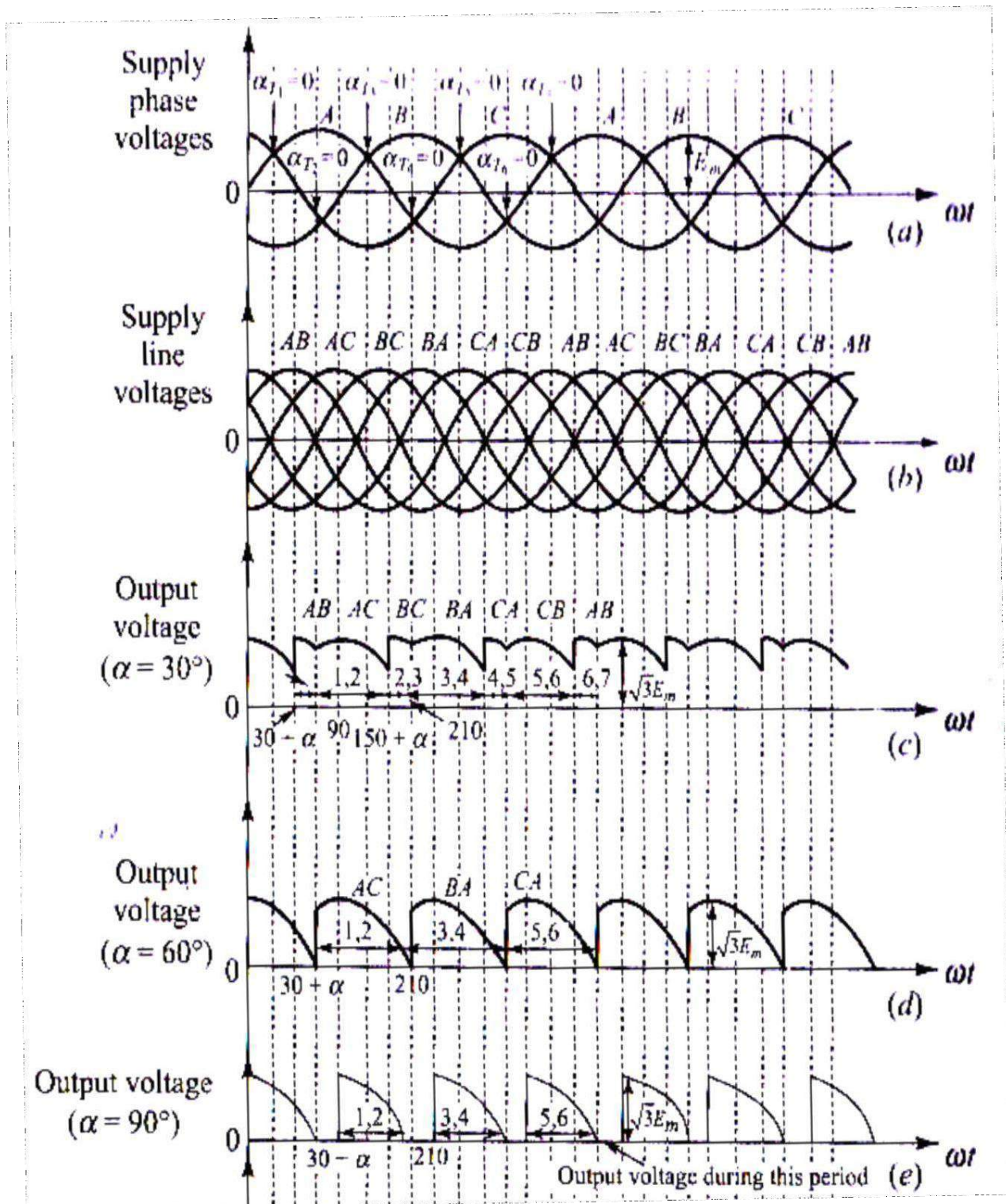
$$= \frac{3\sqrt{3} E_m}{2\pi} [1 + \cos(60 + \alpha) - \cos(120 + \alpha)] = \frac{3\sqrt{3} E_m}{2\pi} [1 + \cos \alpha]$$

**Case II**  $\alpha \geq 60^\circ$ ,  $E_{dc} = 3 \times \frac{1}{2\pi} \left[ \int_{30+\alpha}^{210} E_{Ac}(\omega t) d\omega t \right]$

Substitute the value of  $E_{AC}$ , we get,

$$E_{dc} = \frac{3}{2\pi} \int_{30+\alpha}^{210} \sqrt{3} E_m \sin(\omega t - 30) d\omega t = \frac{3\sqrt{3} E_m}{2\pi} [\cos(\omega t - 30)]_{210}^{30+\alpha}$$

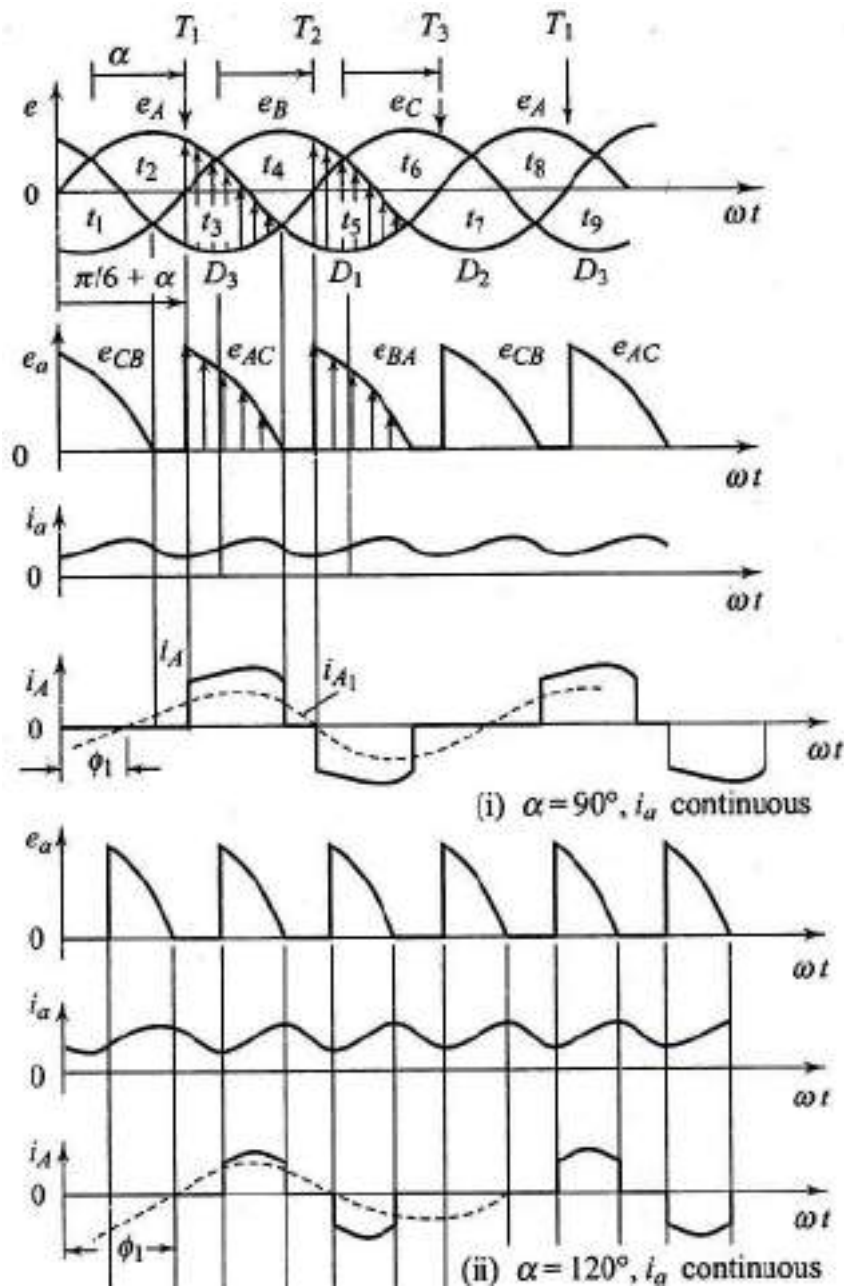
$$= \frac{3\sqrt{3} E_m}{2\pi} [\cos(\alpha) - \cos(180)] = \frac{3\sqrt{3} E_m}{2\pi} (1 + \cos \alpha) \quad (6.54 \text{ (b)})$$





**Fig: The voltage waveforms in a 3 $\phi$  semi converter for firing angles  $\alpha = 0^\circ, 30^\circ, 60^\circ, 90^\circ$**

The waveforms of current and voltage are shown in a different manner for firing angles  $\alpha = 90^\circ$  and  $120^\circ$  for continuous motor currents in the figure below. Firing instants are marked for  $\alpha = 90^\circ$  and shown in the waveforms.



**Fig: Waveforms in a three Phase full converter connected to a DC separately excited motor for  $\alpha = 90^\circ$  &  $120^\circ$  .**

- The conduction periods of the diodes and the thyristors are shown in terms of instants of time  $t_1$  to  $t_6$ . As shown, the diodes D1, D2 and D3 conduct during the intervals  $t_4$  to  $t_6$ ,  $t_6$  to  $t_8$  and  $t_2$  to  $t_4$  respectively. If thyristors T1, T2 and T3 were also diodes they would have conducted during the periods  $t_1$  to  $t_3$ ,  $t_2$  to  $t_5$  and  $t_5$  to  $t_7$  respectively. Therefore the references for the triggering angles for T1, T2 and T3 are taken as the instants  $t_1$ ,  $t_3$  and  $t_5$  respectively. They are the crossing points for the phase voltages  $e_A$ ,  $e_B$ , and  $e_C$
- As shown, thyristor T1 and Diode D1 conduct during the interval  $\omega t = (30^\circ + \alpha)$  to  $\omega t = \omega t_4$  and the voltage  $e_{AC}$  gets applied to the motor terminals. At  $\omega t_4$ ,  $e_A$  becomes negative with respect to both  $e_B$  and  $e_C$  until the next thyristor T2 is triggered at  $\omega t = (30^\circ + \alpha + 120^\circ)$ . During this period the freewheeling diode  $D_F$  becomes forward biased and the motor current flows through that.

The motor current may be discontinuous at large firing angles if the current demand is low and the speed is not low.

**Torque Speed relationships with Semi converter connected to a DC separately excited motor:**

In terms of average voltages, KVL around the motor armature gives

$$E_a(\alpha) = E_b + I_a R_a = K_a \phi \cdot N + I_a R_a$$

Therefore

$$N = [E_a(\alpha) - I_a R_a] / K_a \phi.$$

Assuming motor current to be continuous, the motor armature voltage as derived above for the semi converter is given by

$$E_a(\alpha) = (3\sqrt{3} E_m / 2\pi)(1 + \cos \alpha)$$

Using this in the above relationship we get

$$N = [(3\sqrt{3} E_m / 2\pi)(1 + \cos \alpha) - I_a R_a] / K_a \phi.$$

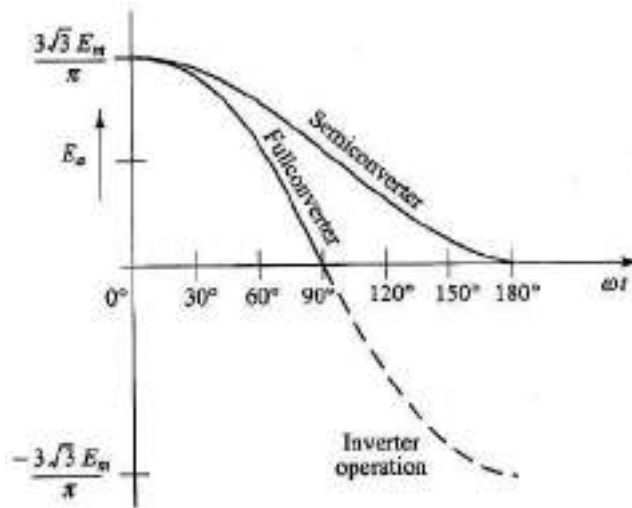
$$N = [(3\sqrt{3} E_m / 2\pi)(1 + \cos \alpha) / K_a \phi] - [I_a R_a / K_a \phi]$$

$$N = [(3\sqrt{3} E_m / 2\pi)(1 + \cos \alpha) / K_a \phi] - [T \cdot R_a / (K_a \phi)^2]$$

As could be seen the relationship is identical to that of a single phase semi converter connected to a DC separately excited motor we have seen earlier ( except that the amplitude of  $E_a (\alpha )$  is different) and the torque speed characteristics are identical ( Same curves can be redrawn here)

**The variation of  $E_a$  as a function of  $\alpha$  in Semi and Full converters:**

The variation of  $E_a$  as a function of  $\alpha$  for continuous motor current is shown in the figure below for both Semi and Full converters. These curves also represent the theoretical no-load speed as a function of firing angle for the separately excited motors. The second term represents the decrease in speed as the motor torque increases. Since the motor armature resistance is small the decrease in speed is small (i.e. good regulation). In large motors, the motor current at no-load is not small and hence if a three phase converter is used, the motor current is more likely to be continuous even at no-load condition. Therefore three phase drives provide better speed regulation and performance compared to single phase drives.



**Fig: The variation of  $E_a$  as a function of  $\alpha$  in Semi and Full converters:**

**Torque Speed relationships with Full converter connected to DC series motor :**

In phase controlled converters for Series motors, the current is mostly continuous and the motor terminal voltage as derived earlier for the full converter is:

$$E_a (\alpha ) =(3\sqrt{3} E_m/\pi)(\cos \alpha )$$

In terms of average voltages, KVL around the motor armature gives:

$$E_a(\alpha) = E_b + I_a R_a = K_a \phi \cdot N + I_a R_a$$

And therefore the average speed is given by :

$$N = [E_a(\alpha) - I_a R_a] / K_a \phi.$$

In series motors Torque is given by:

$$\begin{aligned} T &= K_a \phi \cdot I_a = K_a \cdot K_f \cdot I_f \cdot I_a \\ &= K_{af} \cdot I_a^2 \end{aligned}$$

Hence from the above equation the average speed can be written as:

$$N = [(3\sqrt{3} E_m / \pi)(\cos\alpha) / (K_{af} \cdot I_a)] - [(R_a \cdot I_a / K_{af} \cdot I_a)]$$

$$N = [(3\sqrt{3} E_m / \pi)(\cos\alpha) / \sqrt{(K_{af} \cdot T)}] - [(R_a / K_{af})]$$

And the expression for the torque can be rewritten as

$$T = K_{af} [(3\sqrt{3} E_m / \pi)(\cos\alpha) / (R_a + K_{af} \cdot \omega)]^2$$

*As could be seen the relationship is identical to that of a single phase semi converter connected to a DC series motor we have seen earlier (except that the amplitude of  $E_a(\alpha)$  is different) and the torque speed characteristics are identical (Same curves can be redrawn here)*

### **Torque Speed relationships with Semi converter connected to DC series motor:**

In phase controlled converters for Series motors, the current is mostly continuous and the motor terminal voltage from a Semi Converter can be written as

$$\begin{aligned} E_a(\alpha) &= (3\sqrt{3} E_m / 2\pi)(1 + \cos\alpha) \\ &= I_a R_a + E_b \\ &= I_a R_a + K_{af} \cdot I_a \cdot N \end{aligned}$$

Hence from the above equation the average speed can be written as

$$N = [(3\sqrt{3} E_m / 2\pi)(1 + \cos\alpha) / (K_{af} \cdot I_a)] - [(R_a \cdot I_a / K_{af} \cdot I_a)]$$

$$N = [(3\sqrt{3} E_m / 2\pi)(1 + \cos\alpha) / \sqrt{(K_{af} \cdot T)}] - [(R_a / K_{af})]$$

And the expression for the torque can be rewritten as

$$T = K_{af} [(3\sqrt{3} E_m/2\pi) (1+\cos\alpha)/(R_a + K_{af} \cdot \omega)]^2$$

As could be seen the relationship is identical to that of a single phase semi converter connected to a DC series motor we have seen earlier ( except that the amplitude of  $E_a(\alpha)$  is different) and the torque speed characteristics are identical ( Same curves can be redrawn here )

### Summary:

#### Important conclusions and concepts:

- The ripple frequency of the output of a 3 $\phi$  Half Wave Rectifier is 150 Hz
- The ripple frequency of the output of a 3 $\phi$  Full Wave Rectifier is 300 Hz
- The ripple frequency of the output of a 3 $\phi$  Semi converter is 150 Hz except for  $\alpha = 0^\circ$  when it is 300 Hz
- The ripple frequency of the output of a 3 $\phi$  Full converter is 300 Hz
- The motor current in three phase converters may be discontinuous at large firing angles if the current demand is low and the speed is not low.
- In large motors, the motor current at no-load is not small and hence if a three phase converter is used, the motor current is more likely to be continuous even at no-load condition. Therefore three phase drives provide better speed regulation and performance compared to single phase drives.
- The ripple in the output voltage of a Three phase Full converter is six pulses per cycle. Since there are six thyristors in the circuit, they are fired at a faster rate (once in  $60^\circ$ ) and the motor current is mostly continuous. Therefore the filtering requirement is less than that in the three phase semi converter and single phase converter.

#### Important formulae and equations:

- **Torque Speed relationships with Full converter connected to DC Separately excited motor :**
  - Terminal Voltage  $E_a(\alpha) = (3\sqrt{3} E_m/\pi)(\cos \alpha)$
  - Speed  $N = [(3\sqrt{3} E_m/\pi)(\cos \alpha) / K_a\phi] - [T.R_a / (K_a\phi)^2]$
- **Torque Speed relationships with Semi converter connected to DC Separately excited motor :**
  - Terminal voltage  $E_a(\alpha) = (3\sqrt{3} E_m/2\pi)(1+\cos \alpha)$
  - Speed  $N = [(3\sqrt{3} E_m/2\pi)(1+\cos \alpha) / K_a\phi] - [T.R_a / (K_a\phi)^2]$
- **Torque Speed relationships with Full converter connected to DC series motor :**
  - Terminal Voltage  $E_a(\alpha) = (3\sqrt{3} E_m/\pi)(\cos \alpha)$
  - Speed  $N = [(3\sqrt{3} E_m/\pi)(\cos\alpha)/\sqrt{K_{af}.T}] - [(R_a / K_{af})]$

- 
- Torque  $T = K_{af} [(3\sqrt{3} E_m/\pi)(\cos\alpha)/(R_a + K_{af} \cdot \omega)]^2$
  - Torque Speed relationships with Semi converter connected to *DC series motor* :
    - Terminal voltage  $E_a (\alpha) = (3\sqrt{3} E_m/2\pi)(1+\cos\alpha)$
    - Speed  $N = [(3\sqrt{3} E_m/2\pi)(1+\cos\alpha)/V(K_{af} \cdot T)] - [(R_a/ K_{af})]$
    - Torque  $T = K_{af} [(3\sqrt{3} E_m/2\pi) (1+\cos\alpha)/(R_a + K_{af} \cdot \omega)]^2$

## UNIT – II

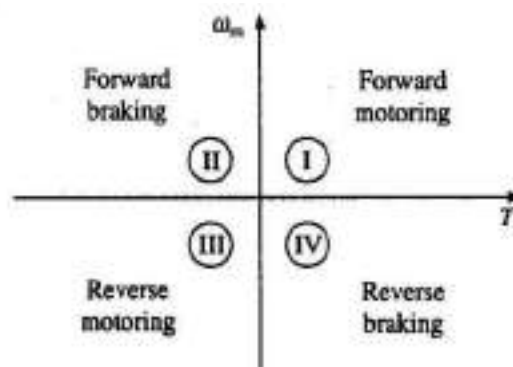
### FOUR QUADRANT OPERATION OF DC DRIVES

#### SYLLABUS/CONTENTS:

- Introduction to Four quadrant operation
- Motoring operations
- Electric Braking – Plugging, Dynamic and Regenerative Braking operations.
- Four quadrant operation of D.C motors by dual converters
- Closed loop operation of DC motor (Block Diagram Only)
- Summary
  - Important concepts and conclusions

### Introduction to Four quadrant operation of electric drives:

An electrical drive has to operate in three modes. i.e. starting, steady state and braking. To achieve this in both directions (forward and reverse) four quadrant operation as shown in the figure below is required which shows the torque and speed coordinates for forward and reverse motions. Power developed by a motor is given by the product of speed and torque.

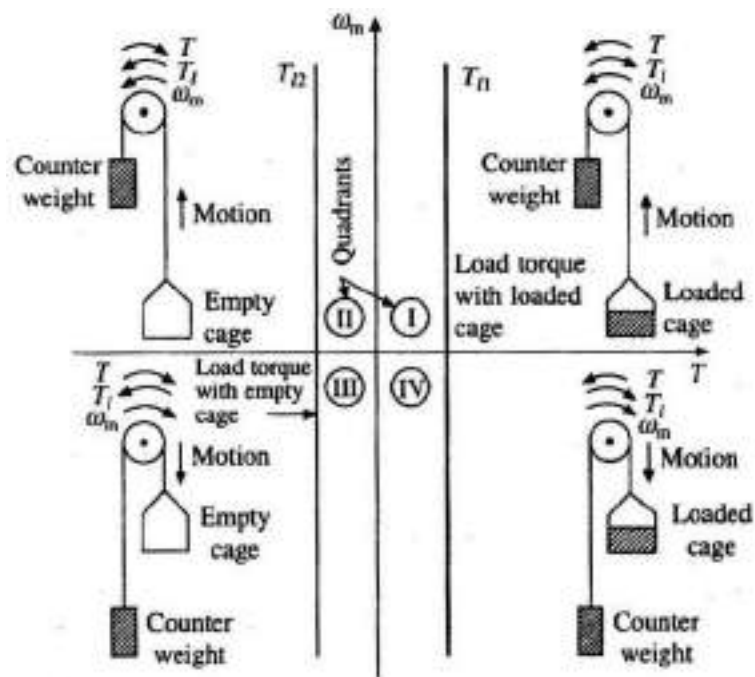


**Fig: Four Quadrant operation of Electrical motors**

- In Q-1 both power & speed are positive. Motor works as a motor delivering mechanical energy to the load. Hence Q-1 operation is designated as Forward motoring.
- In Q-2 power is negative but speed is positive. Motor works as a brake opposing the motion. Hence Q-2 operation is designated as Forward Braking.
- In Q-3 power is positive but speed is reverse. Motor works as a motor delivering mechanical energy to the load. Hence Q-3 operation is designated as Reverse motoring.
- In Q-4 both power and speed are negative. Motor works as a brake opposing the motion. Hence Q-4 operation is designated as reverse Braking.

For a better understanding of the four quadrant operation of the drives and the related notations a practical example of a Hoist (Lift) operating in four quadrants is considered here as shown in the figure below. Directions of motor and load torques and direction of speed are marked with arrows.





**Fig: Typical Example of Four Quadrant operation of a Motor Driving a Hoist (Lift) load.**

A hoist consists of a rope wound on a drum coupled to the motor shaft. One end of the rope is connected to the carriage which carries men and/or material from one level to another level. Other end of the rope is connected to a counterweight to balance the carriage so as to distribute the load on the motor in both directions. Weight of the counterweight is chosen such that it is higher than the empty carriage but lesser than the fully loaded carriage.

Forward direction of motion is considered to be the one which gives upward motion to the carriage.

Load torque characteristics are also shown in the diagram and are assumed to be constant.  $T_{11}$  in quadrants 1 and 4 represents the speed torque characteristic of the loaded carriage. This torque is the difference of torques between loaded hoist and the counter weight and is positive since loaded carriage weight is higher than the counter weight.  $T_{12}$  in quadrants 2 and 3 represents the speed torque characteristic of the empty carriage. This torque is the difference of torques between empty hoist and the counter weight and is negative since empty carriage weight is lesser than the counter weight.

The quadrant I operation of a hoist requires the movement of the cage upward, which corresponds to the positive motor speed which is in anticlockwise direction here. This motion will be obtained if the motor produces positive torque in anticlockwise direction equal to the magnitude of load torque  $T_{l1}$ . Since developed motor power is positive, this is forward motoring operation.

Quadrant IV operation is obtained when a loaded cage is lowered. Since the weight of a loaded cage is higher than that of a counter weight, it is able to come down due to the gravity itself. In order to limit the speed of cage within a safe value, motor must produce a positive torque  $T$  equal to  $T_{l2}$  in anticlockwise direction. As both power and speed are negative, drive is operating in reverse braking.

Operation in quadrant II is obtained when an empty cage is moved up. Since a counter weight is heavier than an empty cage, it is able to pull it up. In order to limit the speed within a safe value, motor must produce a braking torque equal to  $T_{l2}$  in clockwise (negative) direction. Since speed is positive and developed power negative, it is forward braking operation.

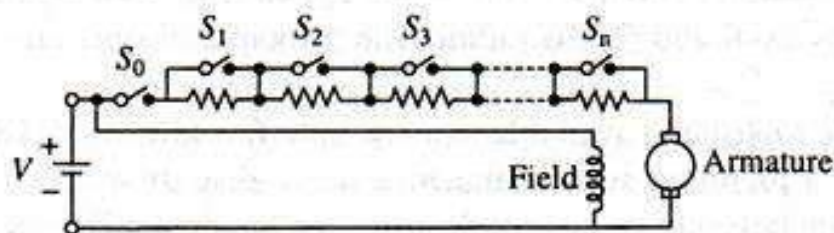
Operation in quadrant III is obtained when an empty cage is lowered. Since an empty cage has a lesser weight than a counter weight, the motor should produce a torque in clockwise direction. Since speed is negative and developed power positive, this is reverse motoring operation.

### Starting:

Maximum current that a DC motor can safely carry is mainly limited by the maximum current that can be commutated without sparking. For normally designed machines twice the rated current can be allowed and in specially designed machines it can be up to 3.5 times the rated current.

During starting when the motor is standstill the motor back emf will be zero and the only resistance that can limit the current is the armature resistance, which is quite small for almost all DC motors. Hence if a DC motor is started with full rated voltage applied to its terminals then a very large current will flow and damage the motor due to heavy sparking in the commutator and heating of the winding. Hence the current is to be limited to a safe value during starting.

In closed loop speed controllers where Speed and current controllers are used the current can be limited to a safe value during starting. But in systems without such controllers a variable resistance controller such as the one shown in figure below is used during starting to limit the current. As the back emf increases with gradual increase in speed, section by section resistances will be removed either manually or remotely with the help of contactors so as to keep the current within the maximum and minimum limits.



**Fig: Starting of a DC Shunt motor****Braking:**

An electrical drive operates in three modes. i.e. steady state ,starting and braking. Braking operation is required in two cases .

- For reducing the speed (deceleration) while the drive is operating in Forward (Quadrant -1 )or Reverse ( Quadrant-3) motoring modes. *Steady state is reached when the motoring torque is equal to the load torque*
- While driving an active load. That means when the load assists the drive motion [for e.g. moving a loaded hoist in the down ward direction (Reverse braking: quadrant-4) or moving an unloaded hoist in the upward direction (Forward braking: quadrant - 2)]. *Steady state is reached when the braking torque is equal to the load torque.*

In both the cases braking can be achieved by mechanical braking. But it has lot of disadvantages: Frequent maintenance like replacement of brake shoes/lining, lower life, wastage of braking power as heat. These disadvantages are overcome by Electrical braking. But many a times mechanical braking also supplements the electrical braking for reliable and safe operation of the drive.

During electric braking the motor works as a generator developing a negative torque which opposes the rotational motion. There are three types of electrical braking.

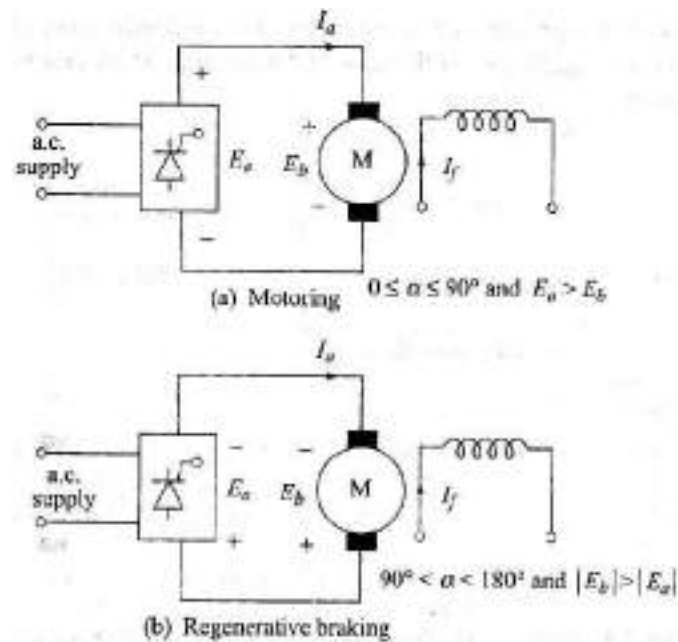
1. Regenerative braking
2. Dynamic or Rheostatic braking and
3. Plugging or reverse voltage braking.

**Regenerative Braking:**

In this, the generated energy is supplied to the source. For this to happen, the following condition should be satisfied:

$$E_b > E_a \text{ and negative } I_a$$

The concept of regenerative braking can be explained by considering a fully controlled Rectifier connected to a DC separately excited motor as shown in the figure (a) below.



**Fig:Two quadrant operation of a Fully Controlled rectifier feeding a DC separately excited motor**

The polarities of output voltage, back emf and armature current are shown for the motoring operation in the forward direction. The converter output is positive with firing angle in the range  $0^\circ \leq \alpha \leq 90^\circ$ . With these polarities the converter supplies power to the motor which is converted to mechanical energy and direction of power flow can be reversed if the direction of current flow is reversed. But this is not possible because the converter can carry current in only one direction. Then the only method available for reversal of power flow is

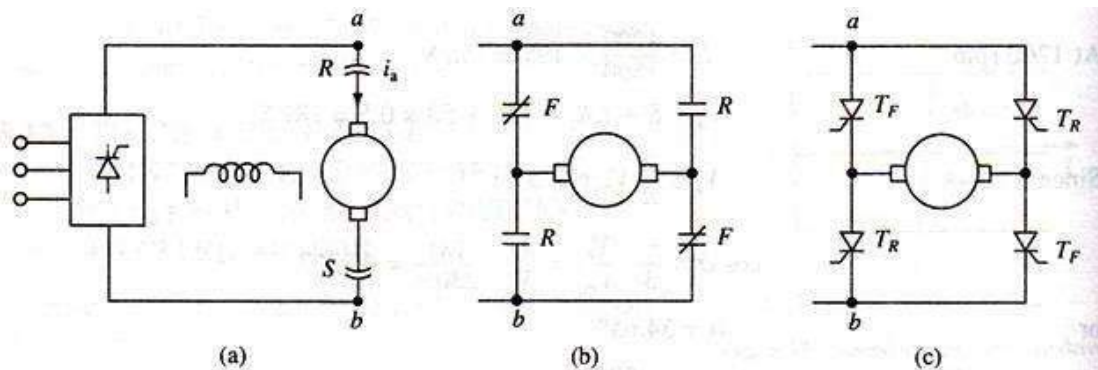
- Reverse the Converter output voltage  $E_a$
- Also reverse the Back emf  $E_b$  with respect to the converter terminals
- And make  $|E_b| > |E_a|$

as shown in fig (b).

- The rectifier voltage  $E_a$  can be reversed by making  $\alpha > 90^\circ$
- The condition  $|E_b| > |E_a|$  can be satisfied by choosing a value of  $\alpha$  in the range  $90^\circ \leq \alpha \leq 180^\circ$
- And the reversal of motor emf with respect to rectifier terminals can be done by any of the following changes.
  - a. An active load coupled to the motor to drive it in the reverse direction. This gives reverse regeneration. (as we have seen in the example of Loaded Hoist moving downwards and operating in the fourth quadrant) In this case no changes are required in armature connection with respect to the converter terminals.
  - b. The motor armature terminals can be reversed w.r.to the converter terminals using a reversing switch with the motor still running in the forward direction.

(with contactors or thyristors as shown in the figure below) This gives forward regeneration.

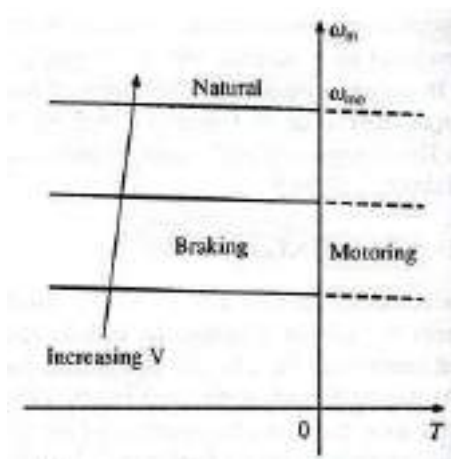
- c. The field current may be reversed with the motor still running in the forward direction and this also gives forward regeneration without any changes in the armature connections.



**Fig: Four quadrant operation with a single converter and a reversing switch**

Regenerative braking cannot be obtained

- If the drive runs in the forward direction only and there is no arrangement for the reversal of either the armature or the field.
- If the converter shown above is a Semi converter.

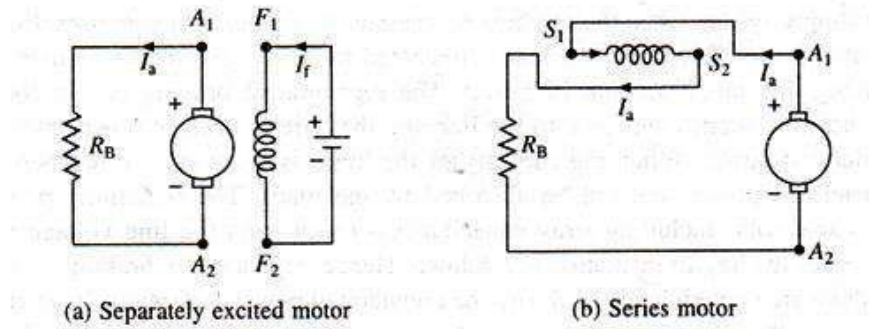


**Fig: Regenerative Braking Characteristics of a Separately excited Motor**

### Dynamic Braking:

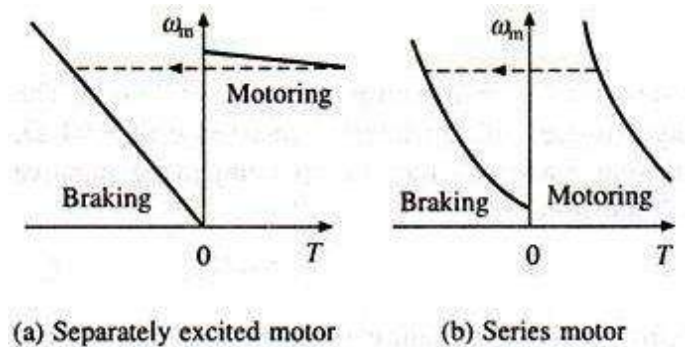
In dynamic braking, the motor armature is disconnected from the source voltage and connected across a high wattage resistance  $R_b$ . The generated energy is dissipated in the

Braking and armature resistances. The braking connections are shown below for DC separately excited motor and DC series motor.



**Fig: Connections during Dynamic Braking**

In the case of a series motor, it can be seen that the field terminal connections are reversed such that the field current continues to flow in the same direction so that the field assists the residual magnetism. Figure below shows the Speed-Torque curves for both type of motors and the transition from Motoring to Braking.

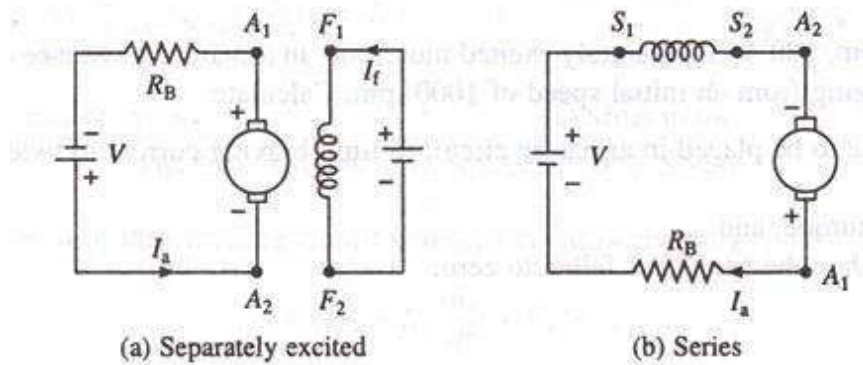


**Fig: Speed-Torque curves during Dynamic Braking**

**Plugging:**

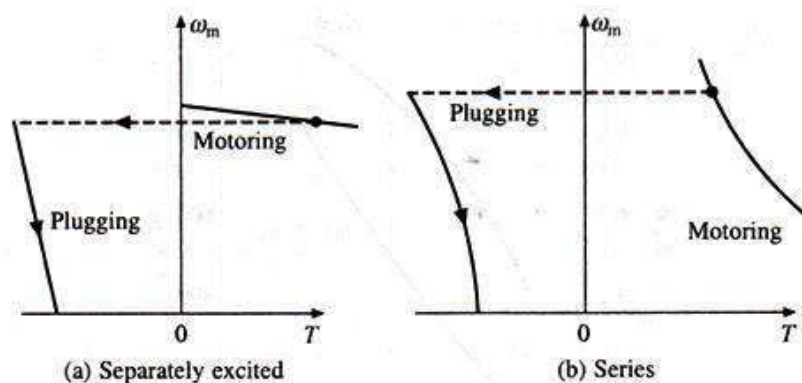
In a DC separately excited motor Supply voltage is reversed so that it assists the Back EMF in forcing the Armature current in the reverse direction. In a Series motor Instead of supply voltage, armature alone is reversed so that the field current direction is not changed. In

addition, like in dynamic braking, a Braking resistor  $R_B$  is also connected in series with the Armature to limit the current as shown in the figure below.



**Fig: Plugging operation of DC motors**

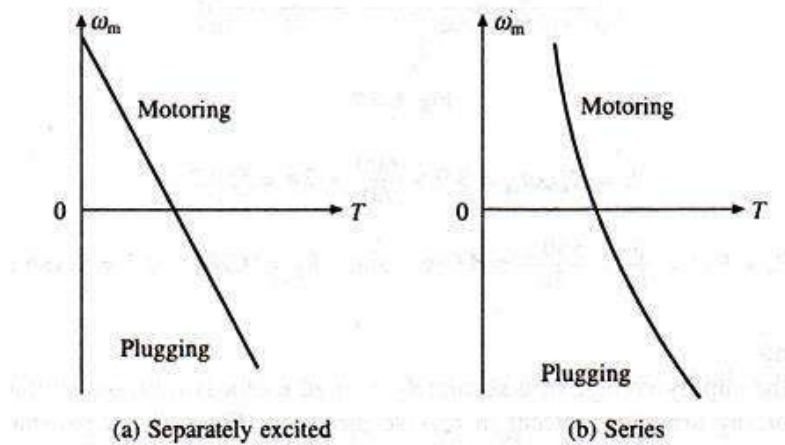
Speed torque curves can be obtained from the same basic equations by replacing  $E_a$  with  $-E_a$  and are shown in the figure below.



**Fig: Torque speed Characteristics of DC motors during Plugging**

A particular case of Plugging for motor rotation in reverse direction arises when a motor is connected for forward motoring, is driven by an active load in the reverse direction. Here also the Back EMF and the applied voltage act in the same direction. However the direction of torque remains positive. This type of situation arises in crane and hoist applications and is called **Counter Torque Braking**. The Torque speed characteristics in Counter Torque Braking area shown in the figure below.

During plugging, since the torque is not zero at zero speed, when used for stopping a load the supply must be disconnected when the load is close to zero speed. Centrifugal switches are used to disconnect the supply.



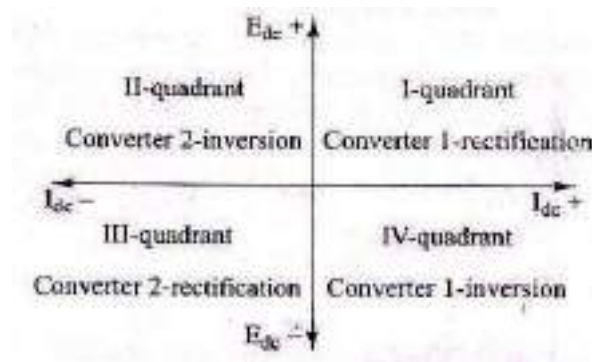
**Fig: Torque speed characteristics in Counter Torque Braking**

Plugging is highly inefficient because in addition to the generated power additional power from a supply source is also wasted in the Braking resistance.



### Four quadrant operation of DC Motors using Dual Converter:

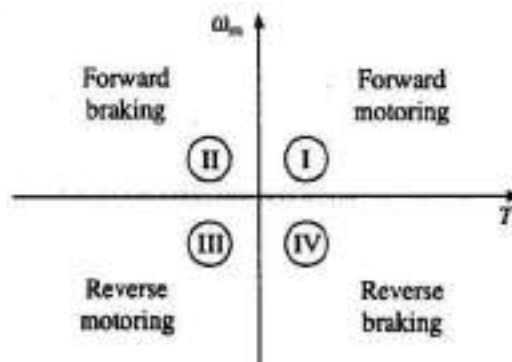
As studied earlier, a fully controlled converter can provide a reversible output voltage and current in one direction. In terms of conventional Voltage-Current diagram shown in the figure below it can work in quadrants 1 and 4



**Fig: Voltage-Current Diagram**

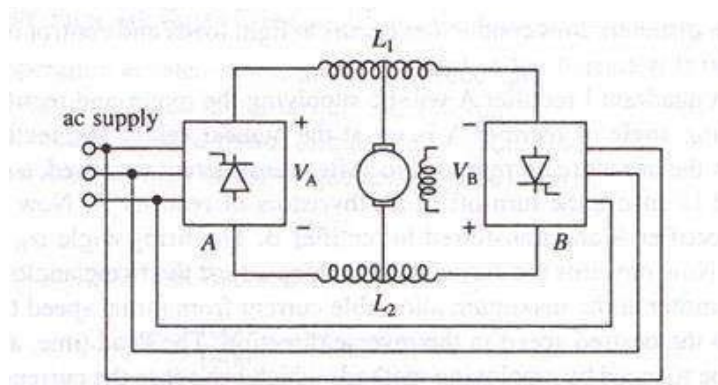
A converter can be used say in the first quadrant for motoring operation alone in one direction (and in the third quadrant for motoring operation in other direction) during steady state conditions. But during transient requirements such as starting and braking it would be required to operate in second (fourth) quadrant also to extract energy from the load for quick braking. (For faster system response)

If four quadrant operation of a motor is required i.e. reversible rotation and reversible torque in the Torque Speed Plane as shown in the figure below, a single converter along



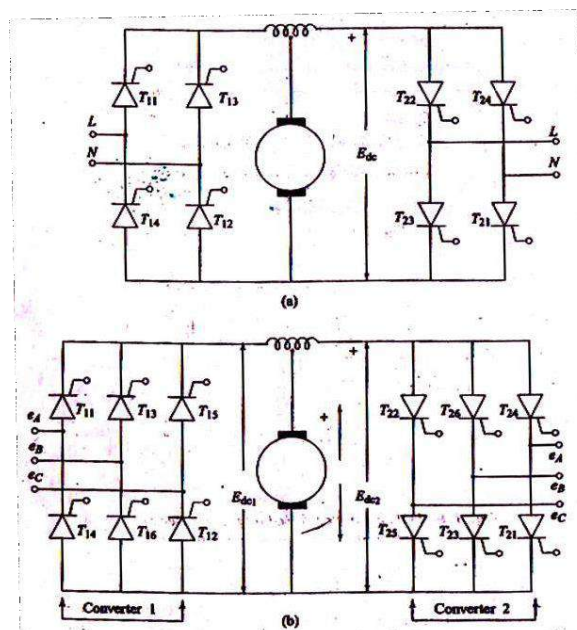
with changeover contactors to reverse the armature or field connections along with firing angle changeover control  $[(0^\circ \leq \alpha \leq 90^\circ) \text{ or } (90^\circ \leq \alpha \leq 180^\circ)]$  can be used so as to change the relationship between the converter voltage and the direction of rotation of the motor. (As explained in the introduction to Regenerative braking). Though they are practicable, a better performance can be achieved by going in for a Dual Converter.

A dual converter as shown in the figure below consists of two fully controlled converters connected in anti-parallel configuration across the same motor armature terminals. Since both voltage and current of either polarity can be obtained with a dual converter, it can support four quadrant operation of DC motors.



**Fig: Dual Converter Control of a DC separately excited motor.  
(Inductors L1 and L2 are used in only simultaneous or Circulating current mode)**

For lower power ratings i.e. up to 10 Kw, single phase Full converters are used and for higher ratings three phase Full converters are used. Typical configuration of both Single phase and Three phase Dual converters are shown in the figures below.



**Fig: Single Phase and Three Phase Converters connected as Dual converters.**

In a dual converter the converters are configured such that converter-A works in quadrants 1 and 4 and converter-B works in quadrants 2 and 3.

The operation of Dual converter is explained with the help of an Ideal dual converter ( same figure as shown above but without reactors) with the following assumptions:

- They produce pure DC output voltage without any ac ripple.
- Each two quadrant converter is a controllable DC voltage source with unidirectional current flow. But the current through the load can flow in either direction.

The firing angle of the converters is controlled by a control voltage  $E_{DC}$  such that their DC output voltages are equal in magnitude but opposite in polarity. So, they can drive current through the load in opposite directions as per requirement.

Thus when one converter is operating as a Rectifier and is giving a particular DC output voltage, the other converter operates as an inverter and gives the same voltage at the motor terminals.

The average DC output voltages are given by:

$$E_{DCA} = E_{max} \cos \alpha_A \text{ and}$$

$$E_{DCB} = E_{max} \cos \alpha_B$$

Where  $E_{max} = 2E_m/\pi$  for Single Phase Full converter and

$= 3\sqrt{3}E_{m\text{ph}}/\pi$  for Three Phase Full converter

In an Ideal converter

$$E_{DC} = E_{DCA} = -E_{DCB}$$

and substituting the above values of  $E_{DCA}$  and  $E_{DCB}$  in this equation we get

$$E_{max} \cos \alpha_A = -E_{max} \cos \alpha_B$$

$$\text{or } \cos \alpha_A = -\cos \alpha_B$$

$$= \cos(180^\circ - \alpha_B)$$

$$\text{or } \alpha_A = 180^\circ - \alpha_B$$

$$\text{or } (\alpha_A + \alpha_B) = 180^\circ$$

The terminal voltage as a function of the firing angle for the two converters is shown in the figure below. A firing angle control circuit has to see that as the control voltage  $E_c$  changes the firing angles  $\alpha_A$  and  $\alpha_B$  are to satisfy the above relation  $(\alpha_A + \alpha_B) = 180^\circ$

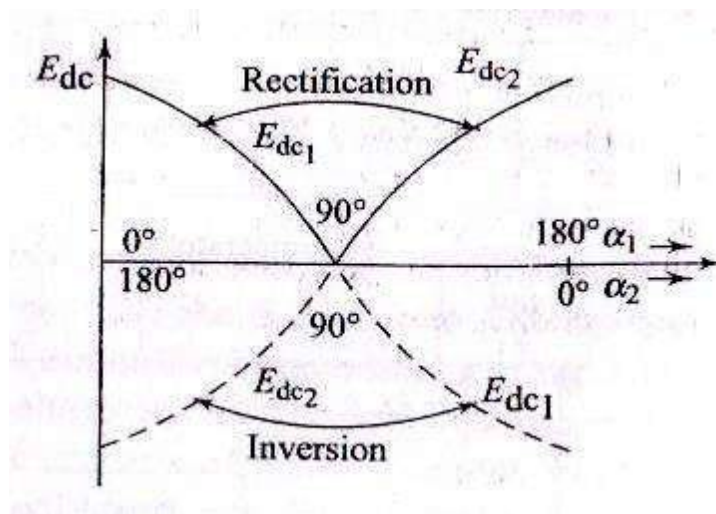


Fig: Firing angle versus Terminal voltage in Dual converter

### Practical Dual Converters:

In the above explanation of the Dual Converter it is assumed that when the firing angle is controlled as per the above equation the output voltage is a pure DC voltage with out any AC ripple. But in practical dual converters there will be AC ripple and hence the instantaneous voltages from the two converters will be different resulting in circulating current which will not flow through the load. If these are not limited they will damage the converters. Hence in order to avoid/limit such circulating currents two methods are adopted.

**Method 1: Dual Converter without circulating current:** In this mode the flow of circulating current is totally inhibited by controlling the firing Pulses such that only one converter which is required to conduct the load current is active at a time. The other converter is kept inactive by blocking its firing pulses. Since only one converter is operating and the other one is in blocking state, no reactor is required.

Suppose converter-A is operating and supplying the load current in a given direction and the converter-B is blocked. If now direction is required to be changed, the pulses to converter-A are withdrawn and load current gets reduced to zero. Now converter-B is made operational by applying the firing pulses and it would build up the current through the load in the other direction. The pulses to Converter-B are applied only after confirming that the current through the load due to converter-A has completely come to zero and in addition after a further gap of a few milli seconds to ensure reliable commutation of converter-A.

*Speed reversal is carried out as follows: When operating in quadrant-1 Converter-A will be supplying the motor current and converter-B is not operational. The firing angle of Converter-A is set at the maximum value. Converter-A then starts working as an Inverter and forces the armature current to zero. After zero current is sensed, firing pulses for converter-A are withdrawn, a further dead time of a few milli seconds is allowed and then firing pulses are given to the converter-B. The firing angle  $\alpha_B$  is initially set at the highest value. Now*

onwards the current loop adjusts the firing angle continuously so as to brake the motor at the highest possible current (torque) from initial speed to zero speed and then accelerates it to the desired speed in the opposite direction. The dead time and hence the reversal time can be reduced by going for accurate zero current sensing methods. When this is done nonsimultaneous control provides faster response than simultaneous control. Because of these advantages nonsimultaneous control is more widely used.

In this method at certain load conditions the load current may not be continuous which is not a desirable operating condition. To avoid this second method is used.

**Method 2: Dual converter with circulating current:** In this mode Current limiting reactors are introduced between the DC terminals of the two converters as shown in the figure to allow the flow of circulating current due to the AC ripple/unequal voltages. Just like in an Ideal Dual converter the firing angles are adjusted such that

$$(\alpha_A + \alpha_B) = 180^\circ. \text{-----(1)}$$

For e.g. Firing angle of converter A is say  $60^\circ$ , then the firing angle of converter B will be  $120^\circ$ . With these firing angles, Converter A will be working as a converter and converter B will be working as an inverter. So, in circulating current mode both converters will be operating. The operation of the converters is interchanged if the load current direction is to be reversed. i.e. converter1 which was working as a converter would now work as an Inverter and converter 2 which was working as an Inverter would work as a converter. Two separate firing circuits have to be used for the two converters.

Speed reversal is carried out as follows. When operating in quadrant 1 Converter-A will be working as a rectifier ( $0^\circ \leq \alpha \leq 90^\circ$ ) and converter-B will be working as an Inverter ( $90^\circ \leq \alpha \leq 180^\circ$ ) For speed reversal  $\alpha_A$  is increased and  $\alpha_B$  is decreased while simultaneously satisfying the above condition (1)

Converter output voltages will reduce faster than the speed and hence the motor back emf exceeds the magnitude of both  $V_A$  and  $V_B$ . The armature current reduces to zero, reverses direction, shifts to Converter B and the motor will now operate initially in quadrant 2 during braking and then in quadrant 3 during acceleration and finally at the required steady state speed. The current loop adjusts the firing angle  $\alpha_B$  continuously so as to brake the motor at the maximum allowable current from initial speed to zero speed and then accelerates to the desired speed in the opposite direction. As  $\alpha_B$  is changed  $\alpha_A$  is also changed continuously so as to maintain the above relation-1. During this entire operation, the closed loop control system will ensure the smooth transfer from quadrant 1 to quadrant 2 to quadrant 3.

**Advantages and Disadvantages of the Circulating current mode of Dual Converters:****Advantages:**

- (i) Over the whole control range, the circulating current keeps both converters in virtually continuous conduction, independent of whether the external load current is continuous or discontinuous.
- (ii) The reversal of load-current is inherently a natural and smooth procedure due to the natural freedom provided in the power circuit for the load current to flow in either direction at anytime.
- (iii) Since the converters are in continuous conduction, the time response of the scheme is very fast.
- (iv) The current sensing is not required and the normal delay period of 10 to 20 ms as in the case of a circulating current free operation is eliminated.
- (v) Linear transfer characteristics are obtained.

**Disadvantages:**

The circulating current scheme has the following main disadvantages:

- (i) Since the current limiting reactor is required in this scheme, the size and cost of this reactor may be quite significant at high power levels.
- (ii) Since the converters have to handle load as well as circulating currents, the thyristors with high current ratings are required for these converters.
- (iii) The efficiency and power factor are low because of circulating current which increases losses.

In spite of these drawbacks a dual converter with circulating current mode is preferred if load current is to be reversed quite frequently and a fast response is desired in the four-quadrant operation of the dual converter.

**Comparison between Circulating current mode and non circulating current mode Dual converters:**Non Circulating current ModeCirculating current Mode

1. In this mode of operation, only one converter operates at a time and the second converter remains in a blocking state.
2. Converters may operate in discontinuous current mode.
3. Reactors may be needed to make load-current continuous.
4. Since no circulating current flows through the converters, efficiency is higher.
5. Due to discontinuous current, non-linear transfer characteristics are obtained.

In this mode of operation, one converter operates as a rectifier and the other converter operates as an inverter.

Converters operates in continuous current mode.

Reactors are needed to limit circulating current. These reactors are costly.

Circulating current flows through the converters and hence increases the losses.

Due to continuous current, linear transfer characteristics are obtained.

Non Circulating current Mode	Circulating current Mode
6. Due to discontinuous current, response is sluggish.	Due to continuous-current in the converters, response is fast.
7. Due to spurious firing, faults between converters results in dead short-circuit conditions.	Due to spurious firing, fault currents between converters are restricted by the reactor.
8. In this mode of operation, the cross-over technique is complex.	In this mode of operation, the crossover technique is simple.
9. Loss of control for 10 to 20 ms is observed in this mode of operation.	Since converters do not have to pass through blocking unlocking and safety intervals of 10 to 20 ms, hence control is never lost in this mode of operation.
10. The control scheme needs command module to sense the change in polarity.	As both the converters are operating at the same time, the control scheme does not require command module.
11. The complete scheme is cheaper compared to circulating current mode.	The complete scheme is expensive.
12. <u>In this mode of operation, the converter loading is the same as the output load.</u>	<u>In this mode of operation the converter loading is higher than the output load.</u>

### Closed loop control of Drives:

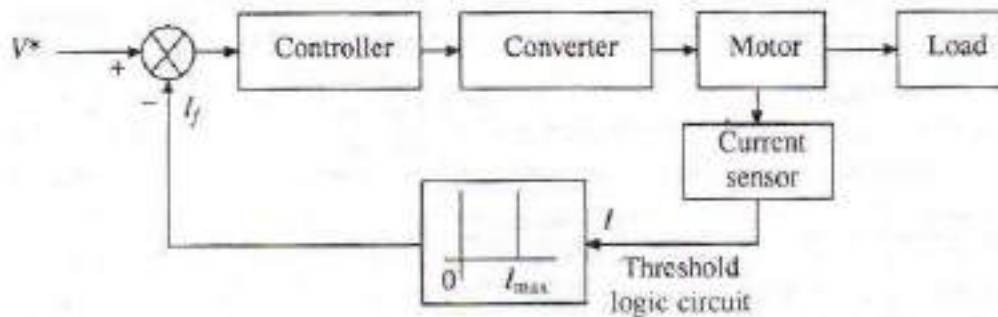
Closed loop control in Electrical drives is provided mainly to meet any or all of the following requirements.

- Protection against over current and over voltages
- Enhancement of Speed of response (Transient performance)
- Improve the steady state accuracy

We will study two important schemes of control that are most commonly used in electrical Drive control systems.

### Current Limit Control:

Basic block diagram of a typical current limit control employed in electrical drives is shown in the figure below.



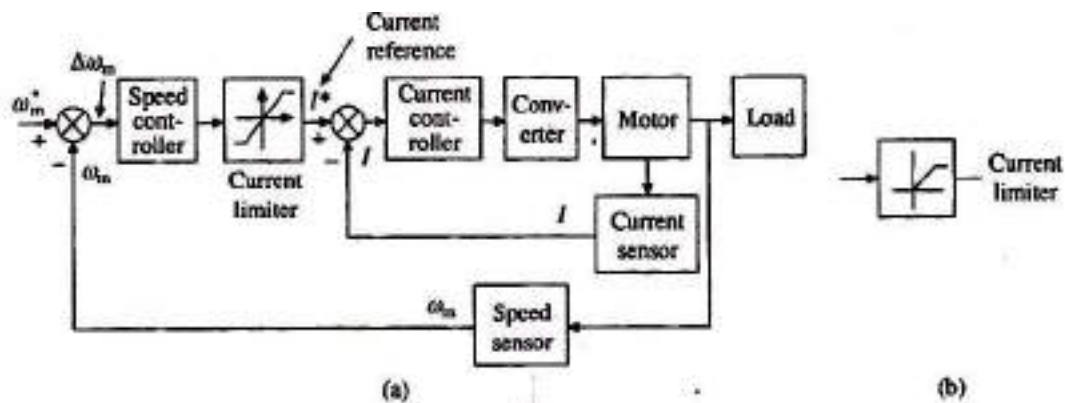
**Fig: Current limit Control**

This is employed mainly to limit the converter and motor currents to safe values during transient periods like starting and braking. It employs a current feedback loop with a threshold logic circuit. The motor current is sensed using sensors like CTs or Hall Effect sensors and fed to the Threshold logic circuit. As long as the motor current is within the set maximum limit, the closed loop control does not come into operation. When the current exceeds the set limit the closed loop control becomes active and the current is forced to be below the set limit and the control loop becomes again inactive. Whenever current exceeds the limit the control loop becomes active again. Thus the current fluctuates around the maximum limit during the transient operations until the drive condition is such that it does not exceed the set maximum current limit. i.e Say during starting, the current fluctuates around the set maximum value till it stabilises at the final steady state condition.

### Closed loop Speed control:

The most widely used control loop in electrical drives is the “closed Speed control” and its Block schematic is shown in the figure below. It employs an inner current control loop





**Fig: Closed loop speed control**

within an outer speed control loop. Inner current control loop is provided to limit the converter and motor current (torque) below the safe limits. It also reduces the effect of any nonlinearities present within the converter- motor system. The speed control loop operates as follows:

$\omega_m^*$  is the speed reference and when it increases it produces a positive speed error  $\Delta\omega_m$ . The speed error is processed through a speed controller and is applied to the current loop as current reference  $I^*$  through the current limiter. Current limiter works linearly in a small range of error and saturates when the error exceed the set limits. The current limiter sets a maximum current reference for the inner current loop at a value corresponding to the maximum allowable current. Drive accelerates at the maximum current and hence with the maximum torque until it approaches the set speed. When it reaches close to the set speed the current limiter desaturates and the speed stabilises at the steady state value with a small steady state error and a current corresponding to the motor torque equal to the load torque.

A decrease in the speed reference  $\omega_m^*$  produces a negative speed error and the current limiter sets a negative maximum current as input to the current loop. Now the motor decelerates and operates in braking mode with maximum allowable current. When it is close to the required speed the limiter desaturates and stabilises at the steady state speed with a small steady state error and current corresponding to a motor torque equal to the load torque.

In drives where there is no provision for current to reverse (single quadrant operation)for braking operation current limiter will have the unipolar I/O characteristics as shown in fig (b).In drive systems where there is enough load torque for braking , electric braking is not required and in such cases also the unipolar current limiter will be used.

Current and speed controllers shown in the speed control loop normally consist of PI (Proportional plus Integral) or PD (Proportional plus Derivative) or PID (Proportional plus Integral plus derivative) controllers depending upon the steady-state accuracy and/or transient response requirements.

**Summary:****Important concepts and conclusions:**

- An electrical drive operates in three modes. i.e. steady state, starting and braking.
- Steady state operation is also referred to as motoring operation.
- Starting and braking are also referred to as transient operations.
- The three types of electrical braking are :
  - Regenerative braking
  - Dynamic or rheostatic Braking and
  - Plugging or reverse voltage braking.
- Four quadrant operation can be achieved with a single Full converter along with changeover contactors to reverse the armature or field connections and with firing angle changeover control [ $(0^\circ \leq \alpha \leq 90^\circ)$  or  $(90^\circ \leq \alpha \leq 180^\circ)$ ]. But Dual converters are preferred due to their superior performance.
- In practical Dual converters with circulating current mode, reactors are required to be connected between the two Converter terminals to limit the circulating currents. The firing angles are to be controlled to satisfy the condition  $(\alpha_A + \alpha_B) = 180^\circ$
- In converters without circulating current only one converter is active at a given time depending on the operation.
- In both modes the closed loop control system takes care of the total control methodology.
- In closed loop speed control systems normally two control loops are used. An inner Current control loop and an outer Speed control loop.
- Current and speed controllers in a closed loop speed control system normally consist of PI (Proportional plus Integral) or PD (Proportional plus Derivative) or PID (Proportional plus Integral plus derivative) controllers depending upon the steady-state accuracy and/or transient response requirements.

**UNIT-III part-ii****CONTROL OF DC MOTORS BY CHOPPERS****SYLLABUS/CONTENTS:**

- Single quadrant, Two quadrant and Four quadrant chopper fed DC Separately excited and series excited motors
- Continuous current operation: Output voltage and current wave forms
- Speed torque expressions
- Speed torque characteristics
- Problems on Chopper fed DC Motors
- Closed Loop operation ( Block Diagram Only)
- Summary
  - Important concepts and conclusions
  - Important formulae and equations

## Introduction to Choppers:

Choppers are mainly used to obtain a variable DC output voltage from Fixed DC voltage source. There are two basic types of choppers: AC link choppers and DC choppers.

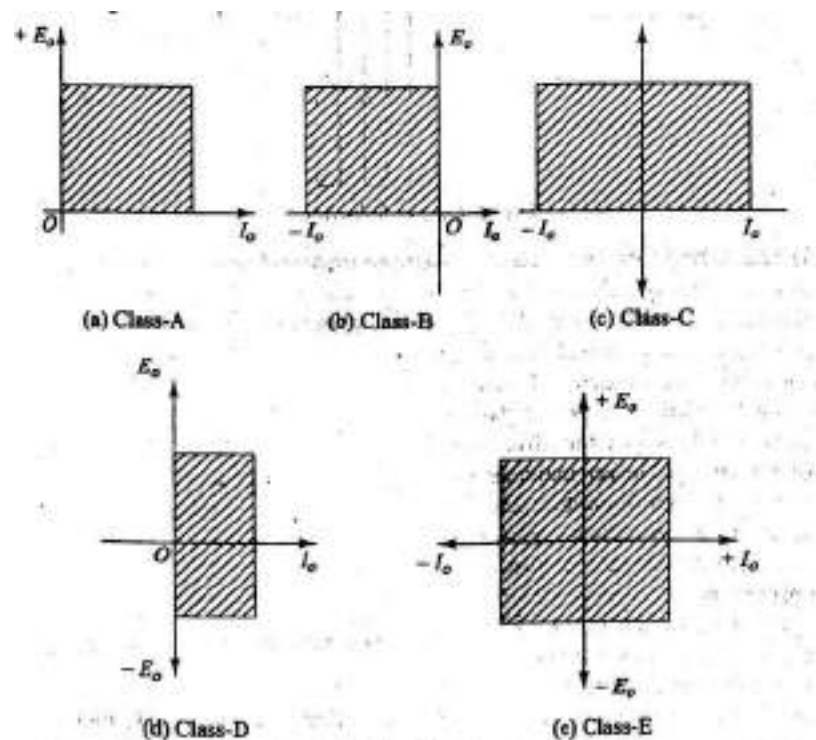
AC link Choppers: In these, first DC is converted to AC by inverters. Then AC is stepped up or down by transformers to the required level and then it is converted back to DC.

DC choppers: In these a variable DC voltage is obtained from a fixed DC voltage using a static switch.

In this unit we will study the application of DC choppers in the Four quadrant operation of DC motors.

Basic DC chopper classification:

- According to the level of input/output voltages:
  - Step down choppers: Output voltage is less than the input voltage
  - Step up choppers: Output voltage is larger than the Input voltage
- According to the Direction of output voltage and current as shown in the figure below ( As class A to E )



### Fig: Classification of DC choppers

- According to quadrants of operation: ( As shown in the figures above. )
  - One quadrant chopper: The output voltage and current are both positive. (class- A) The output voltage is positive but current is negative. (class- B)
  - Two quadrants chopper: The output voltage is positive but current can be positive or negative. ( Class-C ) The output current is positive but voltage can be positive or negative. ( Class-D )
  - Four quadrant chopper: The output voltage and current both can be positive or negative.

#### Basic principle of operation of a step down chopper:

A step down chopper consists of a semiconductor device like SCR, BJT, Power MOSFET, IGBT, GTO etc which works like switch along with a DC input source and other components like Inductors, Resistors, Capacitors, Diodes etc. as shown in the figure below. The average

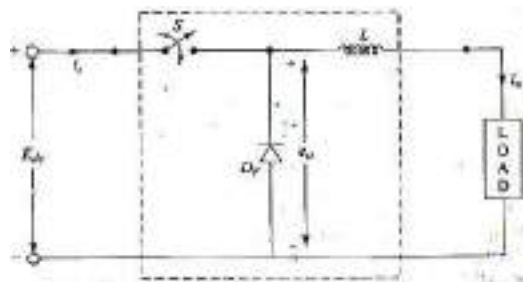
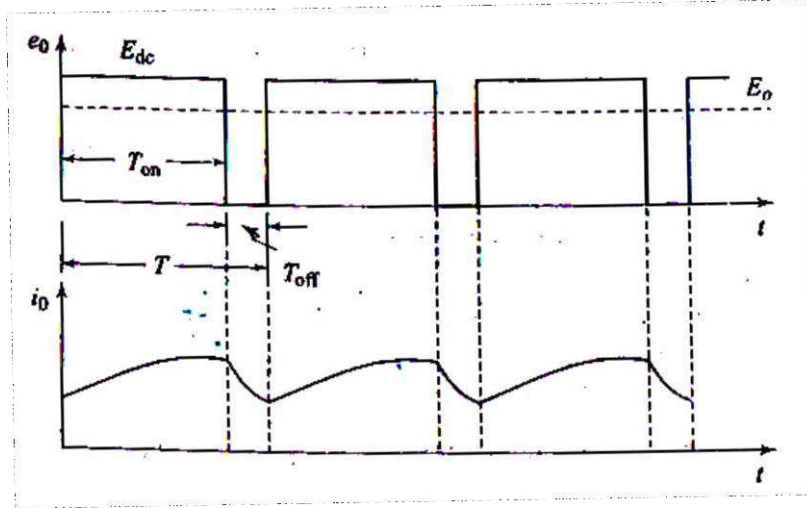


Fig: Basic Chopper circuit

Output voltage across the load is varied by varying the ON period (duty cycle) of the chopper with a given Time period.

For SCR based choppers an additional commutation circuit will be necessary. Hence in general, gate commutation devices like MOSFETs and IGBTs have replaced the SCRs in Choppers. However for high voltage and high current applications SCRs will still be used. The power diode  $D_F$  operates in freewheeling mode and provides a path to the load current

when the switch is not ON. The Inductor works as a filter and smoothes out the switching ripple. The chopped output voltage waveform and the load current are shown in the figure below.



**Fig: DC Chopper output voltage and current waveforms**

During the ON period of the chopper the input voltage gets applied to the load. During the OFF period the load gets short circuited by the freewheeling Diode  $D_F$  and the load current flows through  $D_F$ . Thus a chopped voltage is produced across the load.

The average output voltage is given by :

$$E_o = E_{DC} \cdot T_{ON} / T_{OFF} + T_{ON} = E_{DC} \cdot T_{ON} / T$$

Where  $T_{ON}$  = ON period of the chopper

$T_{OFF}$  = OFF period of the chopper and  $T = T_{OFF} + T_{ON}$  = Chopping period.

$T_{ON} / T$  is called the **duty ratio** of the chopper and is represented by the symbol  $\delta$ .

Then the output voltage  $E_o$  is given by:  $E_o = \delta \cdot E_{DC}$

The output voltage  $E_o$  is also given by:  $E_o = E_{DC} \cdot T_{ON} \cdot f$  where  $f$  is the chopping frequency and is equal to  $1/T$

The average value of the load current is given by:  $I_o = E_o / R = \delta \cdot E_{DC} / R$

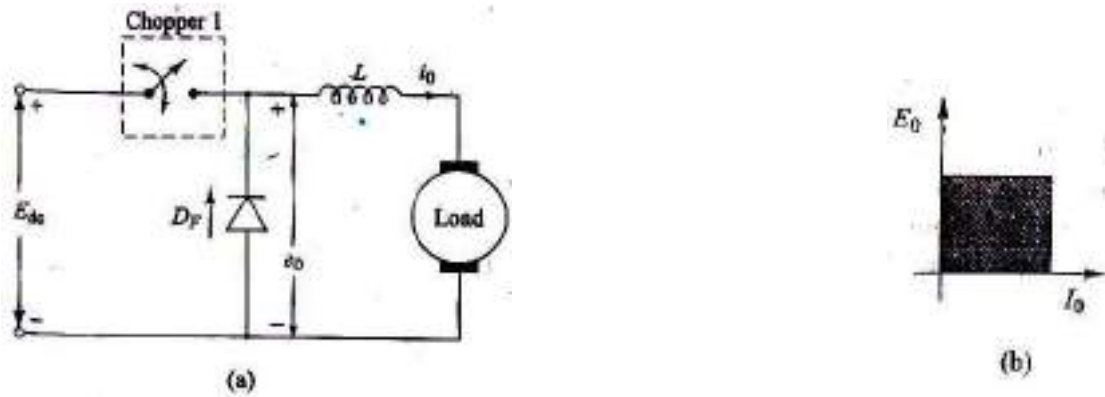
*Types of chopper:*

- If the chopper is transistor based the base current will switch ON and OFF the transistor.
- If it is GTO thyristor based then a positive gate pulse will switch it ON and a negative gate pulse will switch it OFF

- If it is SCR based a commutation circuit is required to turn it OFF.

**Class-A Chopper (First Quadrant operation):**

The basic power circuit of a Class-A chopper connected to a separately excited motor operating in the first quadrant is shown in the figure below.

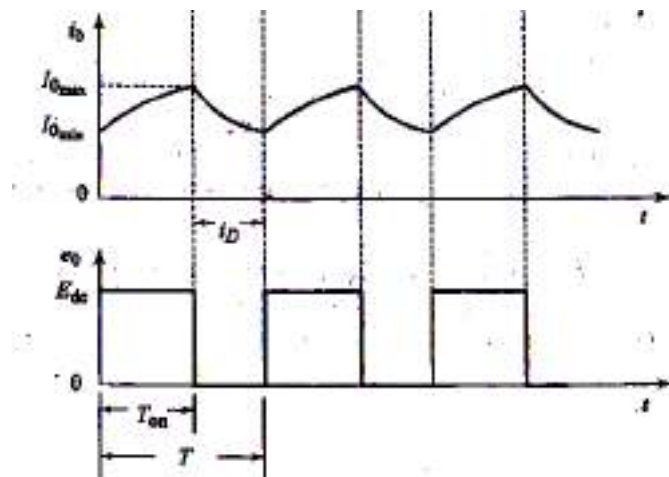


(Draw field circuit and show the polarities of voltage across  $L_a$ ,  $R_a$  and the motor back emf)

**Fig: First quadrant operation of a Class-A chopper connected to a DC separately Excited motor**

The term first quadrant refers to the operation with both voltage and current polarities confined to the directions as shown. When the chopper is ON the output voltage  $E_o = E_{DC}$  and when the chopper is OFF  $E_o = 0$  volts but the current  $I_o$  flows in the load in the same direction through the freewheeling diode  $D_F$ .

Both average load voltage and load current are positive and hence power flows from source to load. **Hence this is Motoring operation.** The output voltage and current waveforms are shown in the figure below.



---

**Fig: Class-A Chopper Voltage and current waveforms with continuous load current**

During the ON period the rate of rise of current is positive and hence the voltage across the Inductance will be positive and the governing relation will be

$$E_{DC} = R_a \cdot i_o + L \cdot di_o/dt + E_b \quad \text{for } 0 < t < T_{on}$$

During the OFF period rate of rise of current is negative and hence the voltage across the Inductance will be negative and the governing relation will be

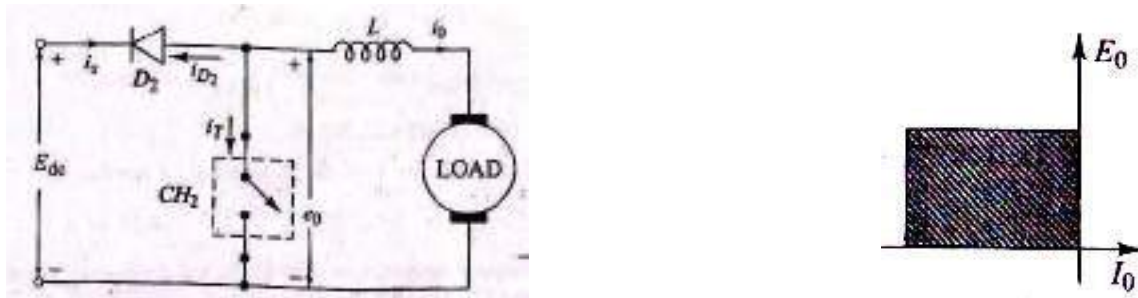
$$0 = R_a \cdot i_o + L \cdot di_o/dt + E_b \quad \text{for } T_{on} < t < T$$

The average output voltage  $E_o$  is given by  $E_o = E_{DC} \cdot \delta$  where  $\delta = \text{duty ratio} = T_{on}/T$ . The torque speed relation is identical to those we have seen earlier with single/three phase converters and is given by:

$$\omega_m = (E_{DC} \cdot \delta / K_a \cdot \phi) - (R_a \cdot T) / (K_a \cdot \phi)^2$$

**Class-B Chopper (Second Quadrant operation):**

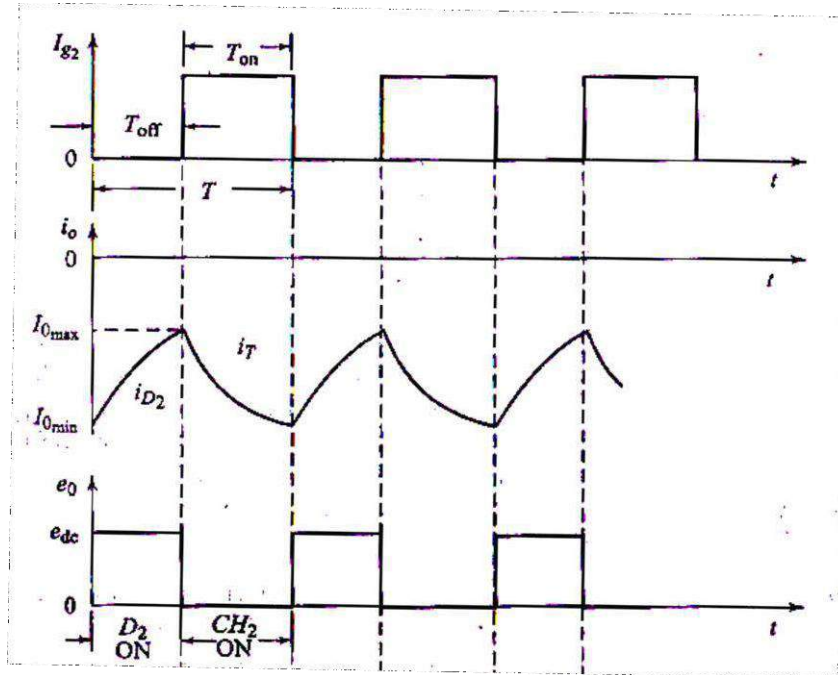
The basic power circuit of a chopper connected to a DC separately excited motor operating in the second quadrant is shown in the figure below. The term second quadrant refers to the operation with both voltage and current polarities confined to the directions as shown.



**Fig: Second quadrant operation of a Class-A chopper connected to a DC separately Excited motor**

Chopper is turned ON and OFF at regular intervals of period T. The back emf  $E_b$  stores energy in the inductance L whenever the chopper is ON and this stored energy is delivered to the source  $E_{DC}$  by flow of current through the diode  $D_2$  and in the same direction through the motor as it was flowing when the chopper was ON. In this, the average load voltage is positive and load current is negative. Hence power flows from load to source. Hence this is **regenerative braking operation**. The output voltage and current waveforms are shown in the figure below.

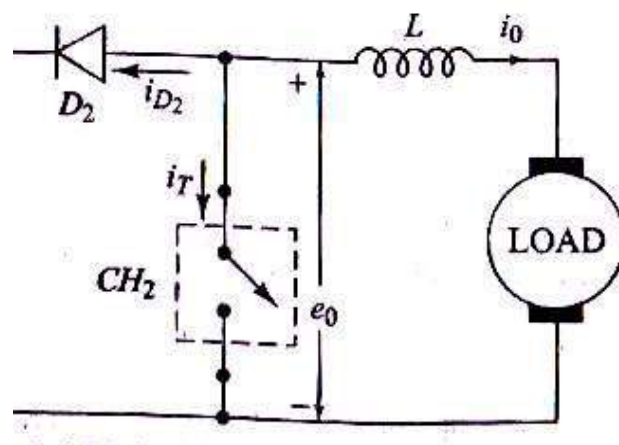




**Fig: Class-B Chopper Voltage and current waveforms with continuous load current**

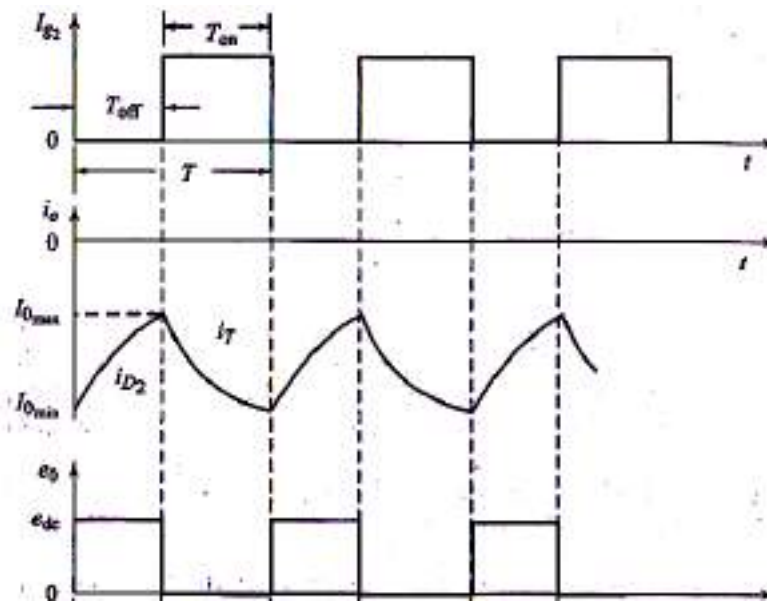
**Dynamic Braking:**

For dynamic braking also the same Class-B chopper which is used for regenerative braking is used except that the braking resistance  $R_B$  is used in place of the supply voltage. The circuit along with the related waveforms are shown in the figures below.



**Fig: Class-B chopper connected to a DC separately excited motor for Dynamic braking.**

**Connect RB Ra field etc.**



**Fig: Voltage and Current waveforms in a Class-B chopper connected to a DC separately excited motor for dynamic braking. ( $I_{D2}$  change as  $I_{RB}$  change max to min also)**

During the interval  $T_{ON}$  when the chopper is ON a part of the motor energy is stored in the Inductance and the remaining power is dissipated in the armature resistance & the chopper. During this period the current flows in the other (reverse) direction and increases from negative minimum to negative maximum. During the interval  $T_{OFF}$  when the chopper is OFF the current decreases from negative (reverse) maximum to negative (reverse) minimum as shown in the waveforms. The energy stored in the Inductance during the period  $T_{ON}$  is now dissipated in the braking resistance  $R_B$  & armature resistance  $R_a$  during this period  $T_{OFF}$ . Chopper controls the magnitude of energy dissipated in the braking resistance and hence the effective value of  $R_B$ .

If  $I_o$  (motor armature current) is assumed to be ripple free, then the energy  $E$  consumed by the braking resistance  $R_B$  during a cycle of chopper operation is given by:

$$E = I_o^2 \cdot R_B \cdot (T - T_{ON})$$

And the power consumed by the braking resistor is given by:

$$\begin{aligned} P &= E/T = I_o^2 \cdot R_B \cdot (T - T_{ON})/T \\ &= I_o^2 \cdot R_B \cdot (1 - \delta) \text{ where } \delta = T_{ON}/T \text{ and} \end{aligned}$$

Effective value of  $R_B$  is given by:

$$R_{BE} = P/I_o^2 = R_B \cdot (1 - \delta)$$

**Chopper control of series motor:**

**Motoring:**

Chopper circuit and the waveforms are same as those of a Class - A chopper connected to a DC separately excited motor. Here also  $E_o = E_{DC} \cdot \delta$  but  $E_b$  will not be constant and varies with  $i_o$ . Due to saturation of the field magnetic circuit, relationship between  $E_b$  and  $I_o$  is non linear. However the basic motor relations we have derived earlier for the series motor are still applicable and are given here again for quick reference.

$$\text{Since } \Phi = K_f \cdot I_a$$

$$E_b = K_a \cdot \Phi \cdot \omega = K_a \cdot K_f \cdot I_a \cdot \omega$$

$$T = K_a \cdot \Phi \cdot I_a = K_a \cdot K_f \cdot I_a^2$$

$$E_a = E_b + I_a \cdot R_a \quad \text{and}$$

$$\omega = E_o / K_a \cdot K_f \cdot I_a \quad -- \quad (R_a / K_a \cdot K_f)$$

$$\omega = [E_o / \sqrt{(K_{af} \cdot T)}] \quad -- \quad [R_a / (K_{af})]$$

Where  $R_a$  is now the sum of armature and field winding resistances and  $K_{af} = K_a \cdot K_f$  is the total motor constant. Using these equations the torque speed relation for a choppers controlled DC series motor would become

$$\omega = [E_{DC} \cdot \delta / \sqrt{(K_{af} \cdot T)}] \quad -- \quad [R_a / (K_{af})]$$

**Regenerative braking:**

For series motor also for regenerative braking the same Class-B chopper that was used for a DC separately excited motor is used. During regenerative braking, series motor works like a self excited series generator. But for self excitation, the current flowing through the field winding should assist the residual magnetism (as already explained during the braking of series motor). Therefore, when changing from motoring to braking connection, while direction of armature current should reverse, field current should flow in the same direction. This is achieved by reversing the field with respect to armature when changing from motoring to braking operation. Voltage and current waveforms will be same as those shown for regenerative braking of a DC separately excited motor.

The governing equations during braking are :

$$E_o = E_{DC} \cdot \delta$$

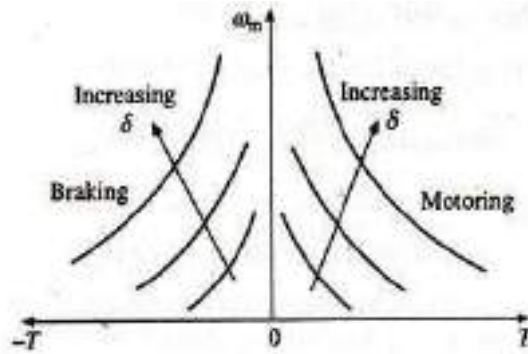
$$E_b = E_o + I_a \cdot R_a$$

$$\omega = E_o / K_a \cdot K_f \cdot I_a + (R_a / K_a \cdot K_f)$$

$$\omega = [E_{DC} \cdot \delta / \sqrt{(K_{af} \cdot T)}] + [R_a / (K_{af})]$$

$$T = - K_a \cdot K_f \cdot I_a^2$$

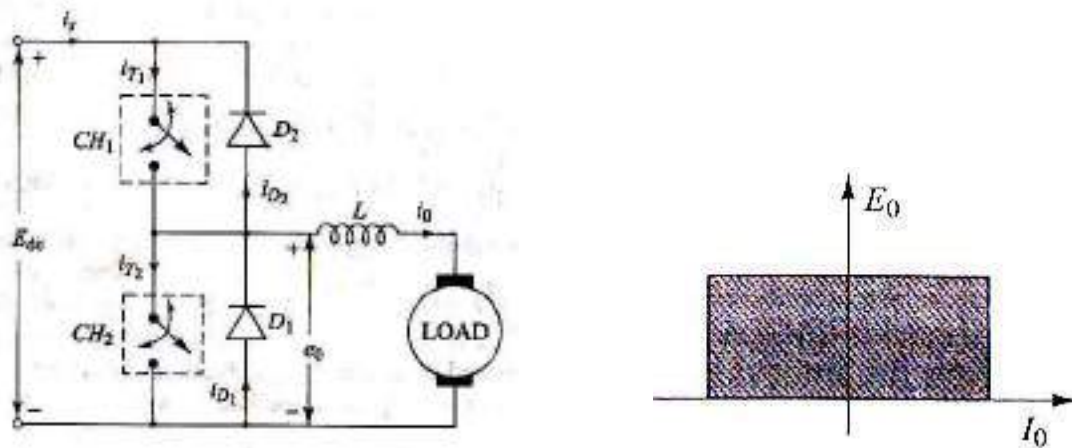
For a chosen value of  $I_a$ ,  $K_f$  is obtained from the magnetisation characteristic. Then,  $\omega$  and  $T$  are obtained from the above equations. The nature of torque speed characteristics is shown in the figure below.



**Fig: Motoring and Regenerative Braking characteristics of a Chopper controlled DC series motor.**

**Two quadrant (type –A) or class-C chopper:**

Class-C chopper can be realised by combining the class-A and class-B choppers together as shown in the figure below. This combined circuit provides both forward motoring and forward regenerative braking. CH1 along with diode D1 performs forward motoring operation while CH2 along with diode D2 performs the function of forward regenerative braking. Thus for motoring operation CH1 is controlled and for braking operation CH2 is controlled. Shifting of control from CH1 to CH2 shifts operation from motoring to braking and vice versa.



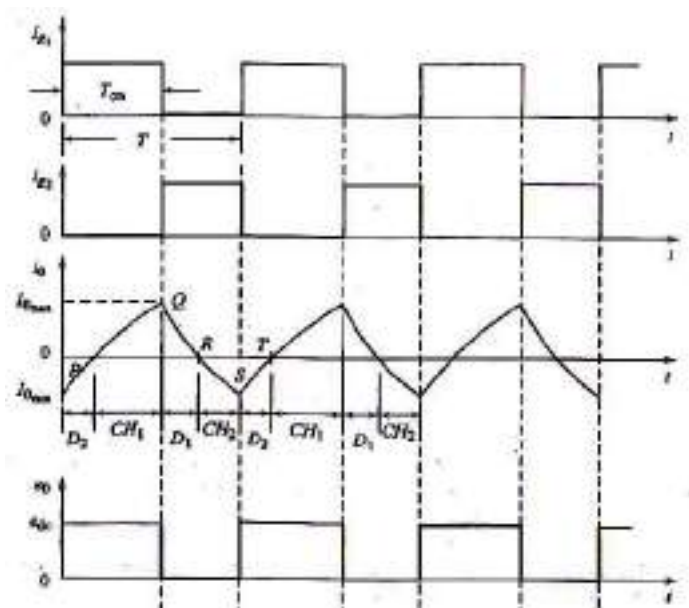
(Motor current direction and  $E_b$  and  $L_a$  polarities to be shown)

**Fig: Two quadrant Type-A (class- C) Chopper and the permissible E-I coordinates**

But in many applications a smooth and fast changeover from motoring to braking and vice versa is required and in such cases Ch1 and Ch2 is controlled simultaneously as explained below with the help of the Motor terminal voltage and the current waveforms shown in the figure below.

**Important points to be noted/conventions followed in this explanation are:**

- With the given polarity of  $E_{DC}$ , the motor current is positive when flowing down wards (during motoring) and negative when flowing upwards (during braking).
- Since we are considering two quadrant operation with forward motoring&braking the polarity of  $E_b$  is considered positive as shown.
- The choppers conduct in the direction as shown by the arrow in the respective chopper when triggered and only when forward biased.
- The voltage across the inductance is positive (terminal a of  $L_a$  is positive) and adds up to the motor back emf  $E_b$  when the rate of rise of current is positive. And this happens when Ch-1 is ON or when diode D2 is conducting.
- The voltage across the inductance is negative (terminal a of  $L_a$  is negative) and opposes the motor back emf  $E_b$  when the rate of rise of current is negative. And this happens when Ch-2 is ON or when diode D1 is conducting.



### Fig: Voltage and current waveforms in a Class-C chopper

#### Operation:

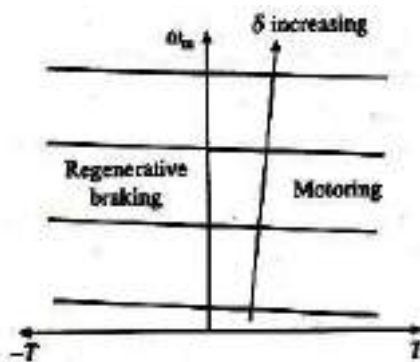
- Initially when both choppers are OFF, both diodes also are not conducting and hence the load is isolated from the source. As shown in the waveforms above, say initially at point P chopper Ch1 is triggered and it starts conducting. The load current is positive and the load receives power from the source. So the output voltage  $e_o = E_{DC}$  whenever chopper Ch1 conducts.
- At point Q chopper Ch1 is turned off, polarity of voltage across inductance  $L_a$  changes (becomes negative) and the energy in the inductance forces load current to flow through the diode D1 ( in the same direction through the motor i.e. positive) till the voltage across the inductance  $L \cdot di/dt$  becomes equal to the back emf  $E_b$  and the load current becomes zero i.e. up to point R.
- At this point R, the motor back emf  $E_b$  is greater than the voltage across the inductance and since the gate signal for Ch2 is present, now  $E_b$  forces a current in the opposite direction (negative current) through  $L_a$  and Ch2. This continues up to point S i.e. until Ch2 is turned off and Ch1 is turned on.
- Now at point S when Ch2 is turned off, polarity of voltage across inductance  $L_a$  changes (becomes positive) and the energy in the inductance forces same negative current through the diode D2 into the source until point T when the input current reduces to zero. In this period the current is negative and hence Ch1 cannot conduct though it is triggered.
- At this point T since gate signal is available to Ch1 load current becomes positive, conducts through Ch-1 and the sequence repeats.

#### Summary observations:

- In a period  $T$ , Ch1 is switched on from  $0$  to  $\delta \cdot T$  and Ch2 is switched on from  $\delta \cdot T$  to  $T$  where  $\delta$  is the duty ratio of Ch1. Therefore during the period  $0$  to  $\delta \cdot T$  motor is connected to the source through Ch1 or D2 depending upon whether the motor current is positive (Ch1) or negative (D2). Since  $E_{DC}$  is always  $> E_b$  during this period the rate of change of current is always positive.
- Similarly during the period  $\delta \cdot T$  to  $T$  motor armature is shorted through Ch2 or D1 depending upon whether the motor current is negative (Ch2) or positive (D1). And during this period the rate of change of current is always negative.
- For first quadrant operation i.e. motoring, torque has to be positive, so motor current has to be positive and thus Ch1 and D1 perform the motoring
- For the second quadrant operation i.e. braking, torque has to be negative, so motor current has to be negative and thus Ch2 and D2 perform the braking

- Load voltage is zero if either Ch2 or diode D1 conducts and equal to  $E_{DC}$  if Ch1 or D2 conducts. So average output voltage is always positive.
- Load current is positive when ever Ch1 or diode D1 conduct and negative when Ch2 or diode D2 conducts.
- Load voltage is positive but current is reversible and hence power flow is also reversible.
- Both Ch1 and Ch2 should not be switched on simultaneously as it would short circuit the source voltage  $E_{DC}$ . They are turned on alternatively as shown by the gate signals  $I_{g1}$  and  $I_{g2}$ .

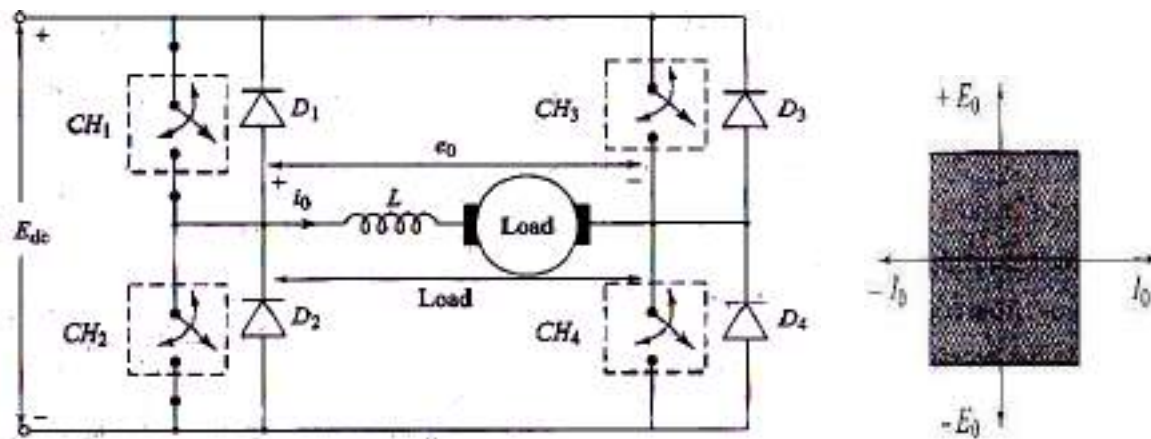
#### Torque- Speed Characteristics:



**Fig: Torque speed characteristics of a Class-C chopper controlled DC separately excited motor.**

#### Four Quadrant or Class-E Chopper:

The circuit diagram of a four quadrant or class-E chopper is shown in the figure below. It can be considered to be consisting of either two Class-C or Class-D choppers together as shown. With this type of chopper motor direction of rotation can be changed without changing the field excitation direction and both motoring and braking operations in both directions can also be obtained by controlling the choppers 1 to 4 as explained below.



**Fig: Four quadrant or class-E chopper circuit Diagram and characteristic.**

With Ch-4 continuously ON and Ch-3 continuously OFF the chopper can be considered to be a Class-C chopper. Controlling choppers 1&2 will make  $E_o$  positive and motor current reversible thus operating in first and second quadrants. Similarly with Ch-2 continuously ON and Ch-1 continuously OFF controlling Ch-3 and Ch-4 will make  $E_o$  negative and motor current reversible thus operating in third and fourth quadrants.

The operation of a Four Quadrant chopper is explained below:

When choppers Ch1 and CH4 are turned ON , current flows through the path:  $E_{DC+}$ , Ch1, load, Ch4,  $E_{DC-}$ . Since both  $E_o$  and  $I_o$  are positive we get First Quadrant operation. When both the choppers Ch1 and Ch4 are turned OFF, load dissipates its' energy through the path: Load,D3, $E_{DC+}$ , $E_{DC-}$ -D2,Load. In this case  $E_o$  is negative while  $I_o$  is positive and Fourth Quadrant operation is possible.

When choppers Ch2 and Ch3 are turned ON current flows through the path:  $E_{DC+}$ , Ch3, load, Ch2,  $E_{DC-}$ . Since both  $E_o$  and  $I_o$  are negative we get Third Quadrant operation. When both the choppers Ch2 and Ch3 are turned OFF,load dissipates its' energy through the path: Load, D1, $E_{DC+}$ , $E_{DC-}$ -D4,Load. In this case  $E_o$  is positive while  $I_o$  is negative and Second Quadrant operation is possible.

This four quadrant chopper circuit consists of two bridges, Forward Bridge and Reverse Bridge. Chopper Bridge Ch1 to Ch4 is the forward bridge which permits flow of energy from source to load. Diode Bridge D1 to D4 is the Reverse Bridge which permits flow of energy from load to source. This Four-Quadrant Chopper configuration can be used for a reversible regenerative DC drive.

### Summary:

### Important concepts and conclusions:



- 
- Choppers are classified as single quadrant (Class-A&B), two quadrant (Class-C&D) and four quadrant (Class-E) depending on the quadrants of operation.
  - They are also classified as step-down and step-up choppers depending on whether the output voltage is lesser than or greater than the input voltage.
  - The duty ratio of a chopper is given by  $\delta = \text{duty ratio} = T_{\text{on}}/T$  where  $T_{\text{on}}$  is the ON time and T is total time period.
  - Choppers conduct in only one direction i.e. when they are forward biased and also when they are triggered to start.
  - The voltage across the Armature inductance is positive and adds up to the motor back emf  $E_b$  when the rate of rise of current is positive.
  - The voltage across the Armature inductance is negative and opposes the motor back emf  $E_b$  when the rate of rise of current is negative

**Important formulae and equations:**

- The output voltage  $E_o$  of a chopper is given by:  $E_o = \delta \cdot E_{DC}$
- The output voltage  $E_o$  is also given by:  $E_o = E_{DC} \cdot T_{\text{ON}} \cdot f$  where  $f$  is the chopping frequency and is equal to  $1/T$
- The average value of the load current is given by:  $I_o = E_o / R = \delta \cdot E_{DC} / R$

---

## UNIT-IV

### SYLLABUS/CONTENTS:

#### Part -1 : CONTROL OF INDUCTION MOTOR THROUGH STATOR VOLTAGE:

- Basic Induction Motor Concepts
  - Development of Induced Torque
  - The concept of Rotor slip
  - The Electrical Frequency on the Rotor
  - Development of Equivalent Circuit and its simplification
  - Power and Torque in Induction Motor
  - Losses and Power flow diagram
  - Derivation of Expressions for Developed Torque, Slip at maximum Torque, Maximum Developed Torque, and Starting Torque
- Variable voltage characteristics
- Speed-Torque characteristics
  - Induced Torque from a Physical Standpoint
- Control of Induction Motors by AC Voltage Controllers
- Waveforms
- Summary
  - Important concepts and conclusions
  - Important formulae and equations

#### Part-2 : CONTROL OF INDUCTION MOTOR THROUGH STATOR FREQUENCY :

- VARIABLE FREQUENCY CHARACTERISTICS
- VARIABLE FREQUENCY CONTROL OF INDUCTION MOTORS BY VOLTAGE & CURRENT SOURCE INVERTERS AND CYCLOCONVERTERS
- PWM CONTROL
- COMPARISON OF VSI AND CSI OPERATIONS
- SPEED TORQUE CHARACTERISTICS
- NUMERICAL PROBLEMS ON IM DRIVES
- CLOSED LOOP OPERATION OF INDUCTION MOTOR DRIVES( BLOCK DIAGRAMS ONLY)
- SUMMARY:
  - IMPORTANT CONCEPTS AND CONCLUSIONS
  - IMPORTANT FORMULAE AND EQUATIONS

### Basic Induction Motor Concepts:

#### The Development of Induced Torque in an Induction Motor:

When current flows in the stator, it will produce a magnetic field in stator as such that  $B_s$  (stator magnetic field) will rotate at a speed:

$$n_s = 120.f_s/P$$

Where  $f_s$  is the system frequency in hertz and  $P$  is the number of poles in the machine. This rotating magnetic field  $B_s$  passes over the rotor bars and induces a voltage in them. The voltage induced in the rotor is given by:

$$e_{ind} = (\mathbf{v} \times \mathbf{B}) l$$

Where  $\mathbf{v}$  is the velocity of the Rotor bars relative to the Stator magnetic field

$\mathbf{B}$  = magnetic flux density vector

And  $l$  = length of the rotor bar in the magnetic field.

Hence there will be rotor current flow which would be lagging due to the fact that the rotor is Inductive. And this rotor current will produce a magnetic field at the rotor,  $B_r$ . Hence the Interaction between these two magnetic fields would give rise to an induced torque:

$$T_{ind} = k.B_r \times B_s$$

The torque induced would accelerate the rotor and hence the rotor will rotate .

However, there is a finite upper limit to the motor's speed due to the following interactive phenomenon:

If the induction motor's speed increases and reaches synchronous speed then the rotor bars would be stationary relative to the magnetic field

↓

No induced voltage

↓

No rotor current

↓

No rotor magnetic field

↓

Induced torque = 0

↓

Rotor will slow down due to friction

**Conclusion:** An induction motor can thus speed up to such a near synchronous speed where the induced torque is just able to overcome the load torque but it can never reach synchronous speed.

#### The Concept of Rotor Slip:

The induced voltage in the rotor bar is dependent upon the *relative speed between the stator Magnetic field and the rotor*. This is termed as slip speed and is given by:

$$n_{slip} = n_{sync} - n_m$$

Where  $n_{slip}$  = slip speed of the machine

$n_{sync}$  = speed of the magnetic field (also motor's synchronous speed) and

$n_m$  = mechanical shaft speed of the motor.

Apart from this we can describe this relative motion by using the concept of **slip** which is the relative speed expressed on a per-unit or percentage basis. **Slip S** is defined as

$$s = \frac{n_{\text{slip}}}{n_{\text{sync}}} (\times 100\%)$$

$$s = \frac{n_{\text{sync}} - n_m}{n_{\text{sync}}} (\times 100\%)$$

On percentage basis and is defined as

$$S = (N_{\text{sync}} - N_m) / N_{\text{sync}}$$

On per unit basis.

Slip  $S$  is also expressed in terms of angular velocity  $\omega$  (Rad/Sec) as given below:

$$s = \frac{\omega_{\text{sync}} - \omega_m}{\omega_{\text{sync}}} (\times 100\%)$$

It can be noted that if the motor runs at synchronous speed the slip  $S=0$  and if the rotor is standstill then the slip  $S=1$ .

It is possible to express the mechanical speed of the Rotor in terms of Slip  $S$  and synchronous speed  $n_{\text{sync}}$  as given below:

$$n_m = (1 - s)n_{\text{sync}}$$

$$\omega_m = (1 - s)\omega_{\text{sync}}$$

### The Electrical Frequency on the Rotor:

An induction motor is similar to a rotating transformer where the primary is similar to the stator and the secondary a rotor. But unlike a transformer, the secondary frequency may not be the same as in the primary. If the rotor is locked (cannot move), the rotor would have the same frequency as the stator. Another way to look at it is to see that when the rotor is locked, rotor speed drops to zero, hence slip is 1. But as the rotor starts to rotate, the rotor frequency would reduce, and when the rotor runs at synchronous speed, the frequency on the rotor will be zero. For any speed in between, the rotor frequency is directly proportional to the difference between the speed of the magnetic field  $n_{\text{sync}}$  and speed of the rotor  $n_m$ . Since slip of the rotor  $S$  is defines as :

$$S = (n_{\text{sync}} - n_m) / n_{\text{sync}}$$

Hence the rotor frequency can be expressed as :

$$f_r = s.f_s$$

Substituting the value of  $S$  above in the expression for  $f_r$  we get

$$f_r = (n_{\text{sync}} - n_m) \cdot f_s / n_{\text{sync}}$$

And then substituting the value of  $f_s$  from the earlier relation  $n_s = 120.f_s/P$

We get

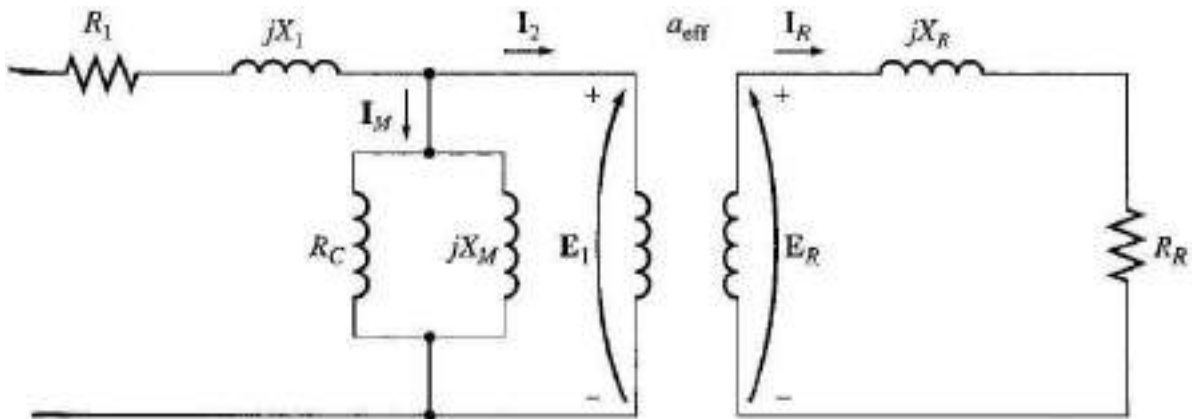
$$f_r = (P/120). ( n_{sync} -- n_m.)$$

**Development of Equivalent Circuit of an Induction Motor:**

An induction motor relies for its operation on the induction of voltages and currents in its rotor circuit from the stator circuit (transformer action). This induction is essentially a transformer operation, and hence the equivalent circuit of an induction motor is developed starting with that of a transformer.

**The Transformer Model of an Induction Motor**

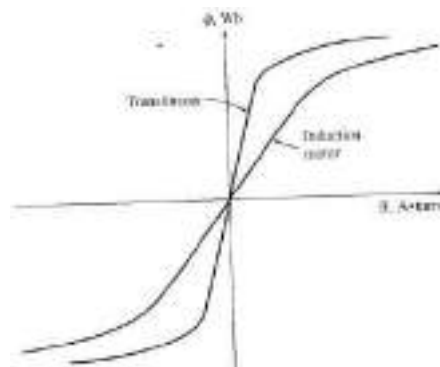
A transformer per-phase equivalent circuit, representing the operation of an induction motor is shown below:



**Fig: The transformer model of an induction motor, with rotor and stator connected by an ideal transformer of turns ratio  $a_{eff}$ .**

As in any transformer, there is certain resistance and self-inductance in the primary (stator) windings, which are represented in the equivalent circuit of the machine. They are  $R_1$ -stator resistance and  $X_1$ -stator leakage reactance

Also, like any transformer with an iron core, the flux in the machine is related to the integral of the applied voltage  $E_1$ . The curve of mmf vs. flux (magnetization curve) for this machine is compared to that of a transformer, as shown below:



**Fig: The magnetisation characteristics of a Transformer vs. Induction motor.**

The slope of the induction motor's mmf-flux curve is much shallower than the curve of a good transformer. This is because there must be an air gap in an induction motor, which greatly increases the reluctance of the flux path and thus reduces the coupling between primary and secondary windings. The higher reluctance caused by the air gap means that a higher magnetizing current is required to obtain a given flux level. Therefore, the magnetizing reactance  $X_m$  in the equivalent circuit will have a much smaller value than that in a transformer.

The primary internal stator voltage is  $E_1$  is coupled to the secondary  $E_R$  by an ideal transformer with an effective turns ratio  $a_{eff}$ . The turns ratio for a wound rotor is basically the ratio of the conductors per phase on the stator to the conductors per phase on the rotor. It is rather difficult to see  $a_{eff}$  clearly in a cage rotor because there are no distinct windings on the cage rotor.

$E_R$  in the rotor produces a current flow in the shorted rotor (or secondary) circuit of the machine. The primary impedances and the magnetization current of the induction motor are very similar to the corresponding components in a transformer equivalent circuit.

**The Rotor Circuit Model:**

When the voltage is applied to the stator windings, a voltage is induced in the rotor windings. In general, the greater the relative motion between the rotor and the stator magnetic fields, the greater is the resulting rotor voltage and rotor frequency. The largest relative motion occurs when the rotor is stationary, called the *locked-rotor* or *blocked-rotor* condition, so the largest voltage and rotor frequency are induced in the rotor at that condition. The smallest voltage and frequency occur when the rotor moves at the same speed as the stator magnetic field, resulting in no relative motion.

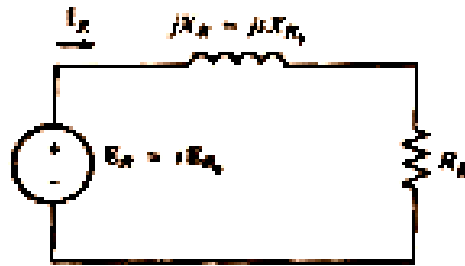
The magnitude and frequency of the voltage induced in the rotor at any speed between these extremes is directly proportional to the slip of the rotor. Therefore, if the magnitude of the induced rotor voltage at locked-rotor conditions is taken as  $E_{R0}$ , then the magnitude of the induced voltage at any slip will be given by:

$$E_R = s \cdot E_{R0}$$

This voltage is induced in a rotor containing both resistance and reactance. The rotor resistance  $R_R$  is a constant, independent of slip, while the rotor reactance is affected in a more complicated way by slip. The reactance of an induction motor rotor depends on the inductance of the rotor and the frequency of voltage and current in the rotor. With a rotor inductance of  $L_R$ , the rotor reactance  $X_R$  is given by :

$$\begin{aligned} X_R &= \omega_r L_R = 2\pi f_r L_R \\ \text{Since } f_r &= s f_s \\ X_R &= s \cdot 2\pi f_s L_R = s X_{R0} \end{aligned}$$

Where  $X_{R0}$  is the blocked rotor reactance. The resulting rotor equivalent circuit is as shown below:



The rotor current is given by :

$$I_R = E_R / ( R_R + jX_R )$$

$$I_R = s \cdot E_{R0} / ( R_R + s \cdot jX_{R0} )$$

$$I_R = E_{R0} / ( R_R/s + jX_{R0} )$$

In the given expression for the rotor current it can be seen that all the effects on **rotor** of varying rotor speed are reflected in the varying impedance  $Z_{Req} = ( R_R/s + jX_{R0} )$  supplied from a constant voltage source  $E_{R0}$ .

In this modified equivalent circuit shown below , the rotor voltage is a constant  $E_{R0}$  and the rotor

impedance contains all the effects of varying rotor slip. Based upon the equation above, at low slips, it can be seen that the rotor resistance is much larger in magnitude as compared to  $X_{R0}$ . At high slips,  $X_{R0}$  will be larger as compared to the rotor resistance. Based on the above equation for the rotor current a plot of  $I_R$  as a function of percentage of synchronous speed is shown in the figure below.

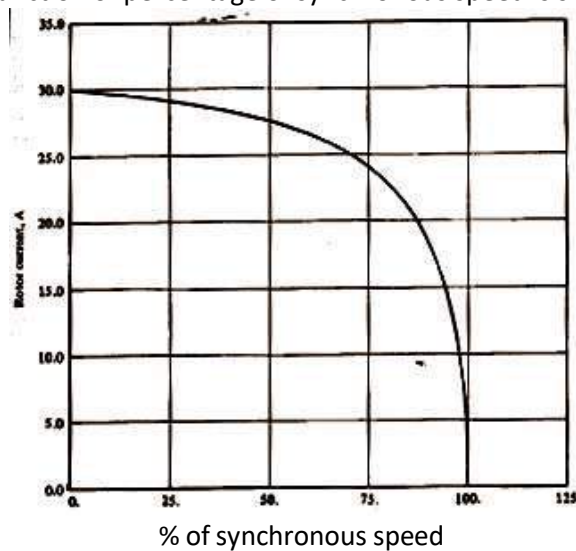


Fig: Rotor current as a function of Rotor speed.

To produce the final per-phase equivalent circuit for an induction motor, it is necessary to refer the rotor part of the model over to the stator side. In an ordinary transformer, the voltages, currents and impedances on the secondary side can be referred to the primary by means of the turns ratio of the transformer:

$$V_p = V'_s = aV_s$$

$$I_p = I'_s = \frac{I_s}{a}$$

and

$$Z'_s = a^2 Z_s$$

Exactly the same sort of transformation can be done for the induction motor's rotor circuit. If the Effective turns ratio of an induction motor is  $a_{eff}$ , then the transformed rotor voltage becomes:

$$E_s = E'_R = a_{eff} \cdot E_{RO}$$

The rotor current becomes:  $I_2 = I_R / a_{eff}$  and the Rotor impedance becomes :

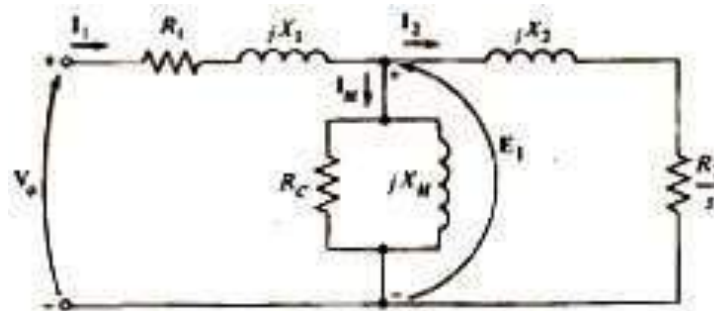
$$Z_2 = a_{eff}^2 \cdot (R_R/s + jX_{R0})$$

And if we give the following definitions :

$$R_2 = a_{eff}^2 \cdot R_R$$

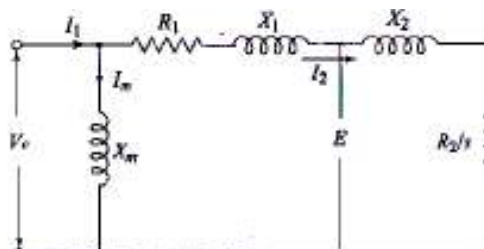
$$X_2 = a_{eff}^2 \cdot X_{R0}$$

Then the final per- phase equivalent circuit of an Induction motor would become as shown in the figure below.



**Fig: Final per-phase equivalent circuit of an induction motor.**

For ease of calculating the motor current and the developed torque the magnetising reactance  $X_m$  is moved to the input side assuming that the drop across the stator resistance is small and the resulting final simplified equivalent circuit is shown in the figure below.



**Fig: Final Simplified Per-phase equivalent circuit of an Induction Motor**

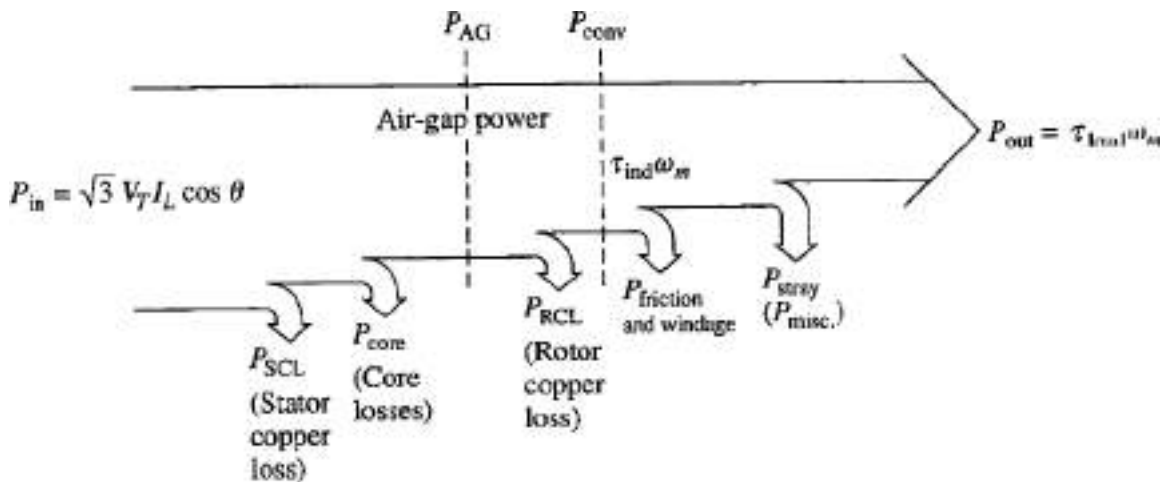


**Power and Torque in Induction Motor:**

Having developed the simplified equivalent circuit of an Induction Motor we will now look at the power flow & losses in an Induction motor and then derive the expressions for the Motor current ,developed torque, Starting torque etc and the relation between Torque and power

**Losses and Power-Flow diagram:**

An induction motor can be basically described as a rotating transformer. Its input is a 3 phase system of voltages and currents. For an ordinary transformer, the output is electric power from the secondary windings. The secondary windings in an induction motor (the rotor) are shorted out, so no electrical output exists from normal induction motors. Instead, the output is mechanical. The relationship between the input electric power and the output mechanical power of this motor is shown below in the power flow diagram:



**Fig: Power flow diagram of an Induction motor.**

The input power to an induction motor  $P_{in}$  is in the form of 3-phase electric voltages and currents. The first losses encountered in the machine are  $I^2R$  losses in the stator windings (the stator copper loss  $P_{SCL}$ ).

Then, some amount of power is lost as hysteresis and eddy currents in the stator ( $P_{core}$ ). The power remaining at this point is transferred to the rotor of the machine across the air gap between the stator and rotor. This power is called the air gap power  $P_{AG}$  of the machine. After the power is transferred to the rotor, some of it is lost as  $I^2R$  losses (the rotor copper loss  $P_{RCL}$ ), and the rest is converted from electrical to mechanical form ( $P_{conv}$ ). Finally, friction and windage losses  $P_{F\&W}$  and stray losses  $P_{misc}$  are subtracted. The remaining power is the output of the motor  $P_{out}$ .

The core losses do not always appear in the power-flow diagram at the point shown in the figure above. Because of the nature of the core losses, where they are accounted for in the machine is somewhat arbitrary. The core losses of an induction motor come partially from the stator circuit and partially from the rotor circuit. Since an induction motor normally operates at a speed near synchronous speed, the relative motion of the magnetic fields over the rotor surface is quite slow, and the rotor core losses are very tiny compared to the stator core losses. Since the largest fraction of the core losses comes from the stator circuit, all the core losses are lumped together at that point on the diagram. These losses are represented in the induction motor equivalent circuit by the

resistor  $R_c$  (or the conductance  $G_c$ ). If core losses are just given by a number (X watts) instead of as a circuit element, they are often lumped together with the mechanical losses and subtracted at the point on the diagram where the mechanical losses are located.

The *higher* the speed of an induction motor, the *higher* the friction, windage, and stray losses. On the other hand, the *higher* the speed of the motor (up to *nsync*), the *lower* its core losses. Therefore, these three categories of losses are sometimes lumped together and called *rotational losses*. The total rotational losses of a motor are often considered to be constant with changing speed, since the component losses change in opposite directions with a change in speed.

### Power and Torque in an Induction Motor:

By examining the per-phase equivalent circuit, the power and torque equations governing the operation of the motor can be derived.

The input current to one phase of the motor is given by :

$$I_1 = V_\phi / Z_{eq}$$

Thus by finding out  $Z_{eq}$  and  $I_1$ , the stator copper losses, the core losses, and the rotor copper losses can be found out.

The stator copper losses in the 3 phases are:  $P_{SCL} = 3 I_1^2 R_1$

The core losses are:  $P_{Core} = 3 E_1^2 G_c$

And the air gap power is:  $P_{AG} = P_{in} - P_{SCL} - P_{Core}$

Also, the only element in the equivalent circuit where the air-gap power can be consumed is in the Resistor  $R_2/s$ . Thus, the air-gap power is given by:

$$P_{AG} = 3 I_2^2 \cdot R_2/s$$

The actual resistive losses in the rotor circuit are given by:

$$P_{RCL} = 3 I_R^2 R_R \quad (I_R \& R_R \text{ are the rotor current and resistance before referring to the stator side})$$

Since power is unchanged when referred across an ideal transformer, the rotor copper losses can also be expressed as:

$$P_{RCL} = 3 I_2^2 R_2$$

And the rotor copper losses are noticed to be equal to slip times the air gap power i.e.  $P_{RCL} = s \cdot P_{AG}$

After stator copper losses & core losses, rotor copper losses are subtracted from the input power to the motor, to get the remaining power which is converted from electrical to mechanical form. The power thus converted, which is called developed (converted) mechanical power is given as:

$$\begin{aligned} P_{conv} &= P_{AG} - P_{RCL} \\ &= 3 I_2^2 \cdot R_2/s - 3 I_2^2 R_2 \\ &= 3 I_2^2 [R_2(1/s) - 1] \\ P_{conv} &= 3 I_2^2 [R_2(1-s)/s] \end{aligned}$$

Hence, the lower the slip of the motor, the lower the rotor losses. Also, if the rotor is not running, the slip is  $s=1$  and the air gap power is entirely consumed in the rotor. This is logical, since if the rotor is not running the output power  $P_{out} (= \tau_{load} \cdot \omega_m)$  must be zero. Since  $P_{conv} = P_{AG} - P_{RCL}$ , this also gives another relationship between the air-gap power and the power converted from electrical to mechanical form:

$$\begin{aligned} P_{conv} &= P_{AG} - P_{RCL} \\ &= P_{AG} - s P_{AG} \\ P_{conv} &= (1-s) P_{AG} \end{aligned}$$

Finally, if the friction, windage and the stray losses are known, the output power:

$$P_{\text{out}} = P_{\text{conv}} - P_{\text{F\&W}} - P_{\text{stray}}$$

The induced torque in a machine was defined as the torque generated by the internal electric to mechanical power conversion. This torque differs from the torque actually available at the terminals of the motor by an amount equal to the friction and windage torques in the machine. Hence, the developed torque is given by :

$$T_{\text{ind}} = P_{\text{conv}} / \omega_m$$

And the other ways to express the torque is :

$$T_{\text{ind}} = (1-s)P_{\text{AG}} / (1-s)\omega_s$$

$$T_{\text{ind}} = P_{\text{AG}} / \omega_s$$

From the above study and the developed simplified equivalent circuit the rotor current is given by

$$I_2 = \frac{V_1}{(R_1 + R_2/s) + j(X_1 + X_2)}$$

$$I_2 = \frac{V_1}{\sqrt{(R_1 + R_2/s)^2 + (X_1 + X_2)^2}}$$

Now, the gross converted mechanical power  $P_{\text{conv}}$  is given by:

$$3I_2^2 R_2 (1-s)/s = \frac{3V_1^2 R_2 (1-s)/s}{(R_1 + R_2/s)^2 + (X_1 + X_2)^2}$$

The developed torque is then given by :

$$T_d = \frac{P_{\text{gross}}}{\omega_r} = \frac{P_{\text{gross}}}{\omega_s (1-s)} = \frac{3V_1^2 R_2 / s}{\omega_s [(R_1 + R_2/s)^2 + (X_1 + X_2)^2]}$$

or  $T_d = \frac{3}{\omega_s} I_2^2 \frac{R_2}{s} \text{ N-m}$

As can be seen, in this equation the slip is the variable. Hence the maximum torque is obtained by taking derivative of the torque with respect to the slip and then setting the derivative to zero. Then we get the slip at maximum torque as

$$S_{\text{max } T} = \pm \frac{R_2}{\sqrt{R_1^2 + (X_1 + X_2)^2}}$$

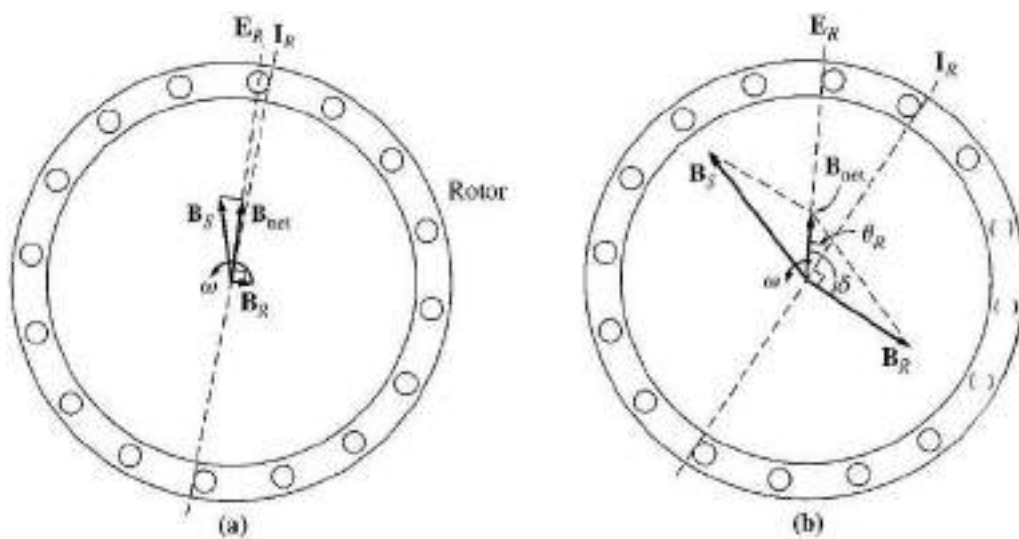
And substituting this value of  $S_{\text{max } T}$  in the above expression for developed torque we get the maximum developed torque  $T_{\text{max}}$  as:

$$T_{\text{max}} = \frac{3V_{1\text{ph}}^2}{2\omega_s [R_1 \pm \sqrt{R_1^2 + (X_1 + X_2)^2}]}$$

**Here while working out problems we have to take the per phase voltage applied to the Induction motor by carefully looking at the input voltage and rotor winding connections.**

**Induction Motor Torque-Speed Characteristics:**

The torque-speed relationship will be examined from the physical viewpoint of the motor's magnetic field behaviour. Then, a general equation for torque as a function of slip will be derived from the Induction motor equivalent circuit.

**Induced Torque from a Physical Standpoint:**

**Fig: The magnetic fields in an induction motor under (a) light loads. (b) heavy loads**

**No-load Condition :**

Assume that the induction motor is already rotating at no load conditions:

- Its rotating speed is near to synchronous speed. The net magnetic field  $\mathbf{B}_{net}$  is produced by the magnetization current  $\mathbf{I}_M$ .
- The magnitude of  $\mathbf{I}_M$  and  $\mathbf{B}_{net}$  is directly proportional to voltage  $\mathbf{E}_1$ . If  $\mathbf{E}_1$  is constant, then  $\mathbf{B}_{net}$  is constant.
- In an actual machine,  $\mathbf{E}_1$  varies as the load changes due to the stator impedances  $\mathbf{R}_1$  and  $\mathbf{X}_1$  which cause varying volt drops with varying loads. However, the volt drop at  $\mathbf{R}_1$  and  $\mathbf{X}_1$  is so small, that  $\mathbf{E}_1$  can be assumed to remain constant throughout.
- At no-load, the rotor slip is very small, so the relative motion between rotor and magnetic field is very small, and hence the rotor frequency is also very small.
- Since the relative motion is small, the voltage  $\mathbf{E}_R$  induced in the bars of the rotor is also very small, and hence the resulting current flow  $\mathbf{I}_R$  is also very small.
- Since the rotor frequency is small, the reactance of the rotor is nearly zero, and the max rotor current  $\mathbf{I}_R$  is almost in phase with the rotor voltage  $\mathbf{E}_R$ .
- The rotor current produces a small magnetic field  $\mathbf{B}_R$  at an angle slightly greater than 90 degrees behind  $\mathbf{B}_{net}$ .
- The stator current will be quite large even at no-load since it must supply most of  $\mathbf{B}_{net}$ .

The induced torque which keeps the rotor running is given by:

$$T_{ind} = k B_r \times B_{net}$$

And its magnitude is:

$$T_{ind} = k B_r B_{net} \sin \delta$$

In terms of magnitude, the induced torque will be small due to small rotor magnetic field.

**On-load Conditions:**

As the motor's load increases, its slip increases, and the rotor speed falls. Since the rotor speed is slower, there is now more relative motion between rotor and stator magnetic fields.

- Greater relative motion means a stronger rotor voltage  $E_R$  which in turn produces a larger rotor current  $I_R$ .
- With large rotor current, the rotor magnetic field  $B_R$  also increases. However, the angle between rotor current and  $B_R$  changes as well.
- Since the rotor slip is larger, the rotor frequency rises ( $f_r = s f_e$ ) and the rotor reactance increases ( $\omega L_R$ ).
- Therefore, the rotor current now lags further behind the rotor voltage, and the rotor magnetic field shifts with increasing load current.
- The rotor current now has increased compared to no-load but the angle  $\delta$  has also increased. The increase in  $B_R$  tends to increase the torque, while the increase in angle  $\delta$  tends to decrease the torque ( $T_{ind}$  is proportional to  $\sin \delta$ , and  $\delta > 90^\circ$ ).
- Since the first effect is larger than the second one, the overall induced torque increases to supply the motor's increased load.
- But as the load on the shaft is increased further, the  $\sin \delta$  term decreases more than the  $B_R$  term increases (the value is going towards the 0 cross over point for a sine wave). At that point, a further increase in load decreases  $T_{ind}$  and the motor stops. The torque at which this happens is known as **pullout torque**.

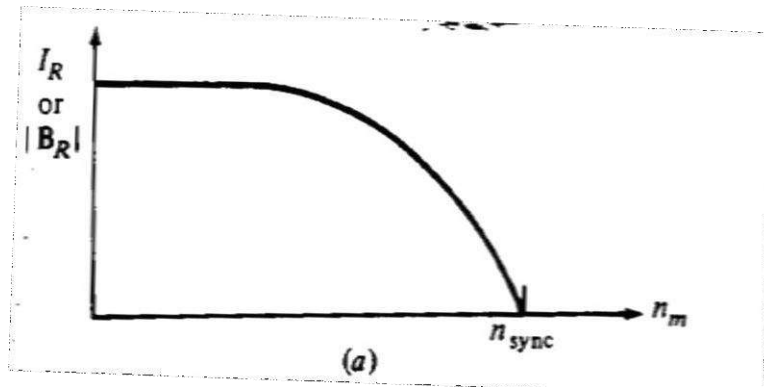
**Developing the torque-speed characteristics of an induction motor:**

As we have already seen the magnitude of the induced torque in the Induction motor is given by:

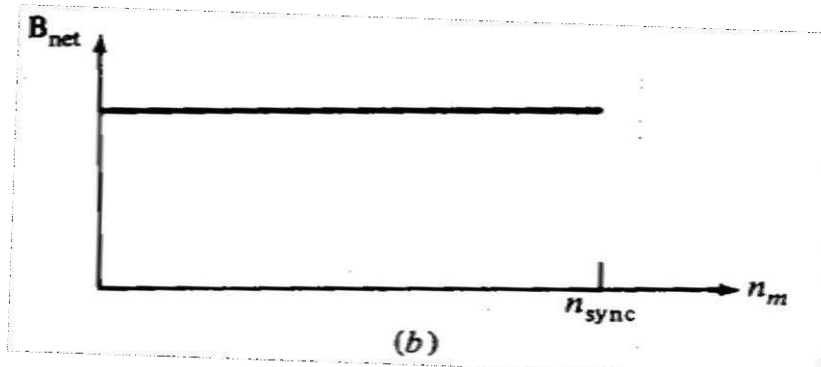
$$T_{ind} = k B_r B_{net} \sin \delta$$

From the motor behaviour from no load to full load as explained above, the overall torque speed characteristics can be developed by considering each of the terms in the above expression for torque .

a)  $B_r$ : Rotor magnetic field is directly proportional to the rotor current and will increase as the rotor current increases (Assuming that the rotor core is not saturated). The current flow will increase as slip increases (reduction in speed). The current flow as a function of motor speed is shown in fig(a) below.



b)  $B_{net}$ : The net magnetic field density  $B_{net}$  will almost remain constant since it is proportional to  $E_1$  (refer to the induction motor equivalent circuit) and  $E_1$  is assumed to be constant). The variation of  $B_{net}$  as a function of motor speed is shown in the fig(b) below.



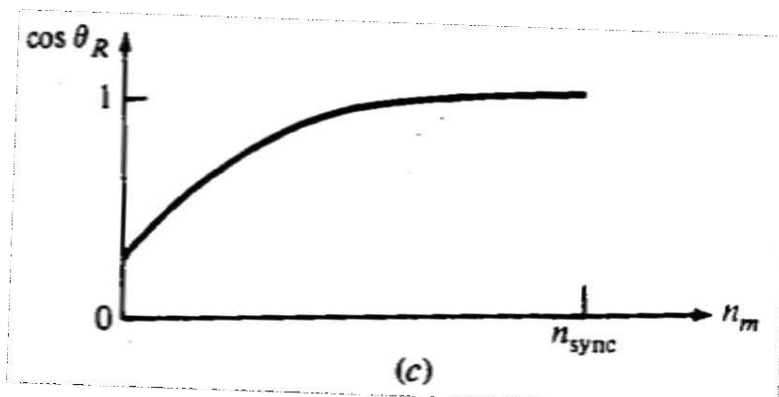
c)  $\sin \delta$  : The angle  $\delta$  between the Net and the Rotor magnetic fields can be expressed in a useful way. Looking at the figure above (magnetic fields on no-load and load) it can be seen that the angle  $\delta$  is equal to the sum of the Rotor power factor angle  $\theta_r$  and  $90^\circ$  ( where  $\theta_r$  is the angle between  $E_R$  and  $I_R$ . (Also note that  $E_R$  is in phase with  $B_{net}$  since it is in phase with  $B_{net}$ ).

$$\text{i.e. } \delta = \theta_r + 90^\circ \text{ and } \sin \delta = \sin(\theta_r + 90^\circ) = \cos \theta_r$$

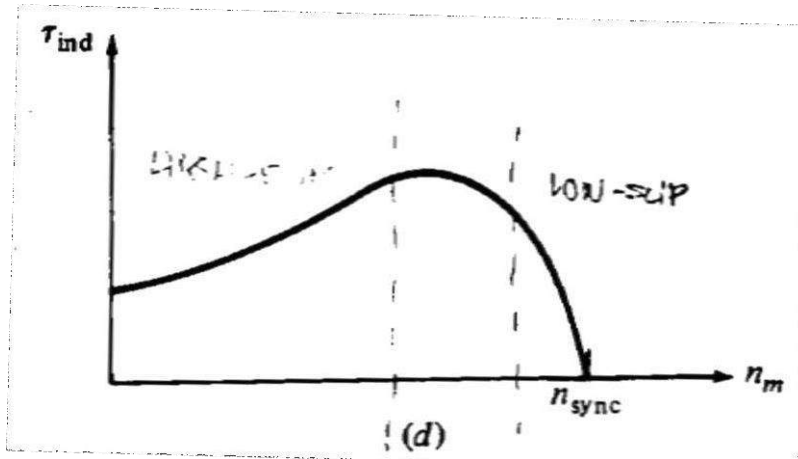
$\cos \theta_R$  is also known as the motor power factor where:

$$\theta_r = \tan^{-1} (X_r / R_r) = \tan^{-1} (sX_0 / R_r)$$

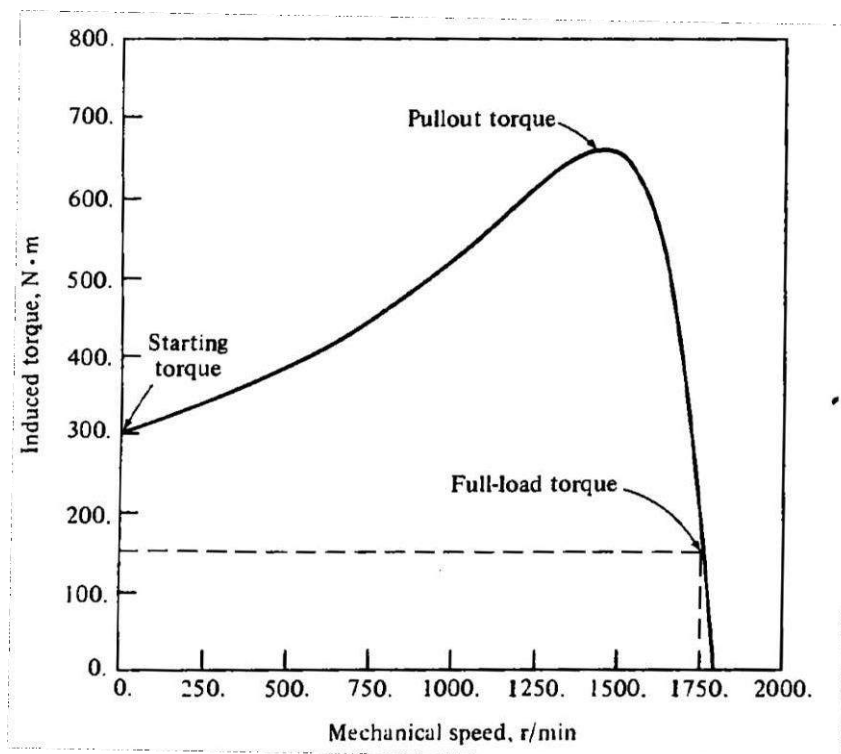
A plot of Rotor power factor vs. Slip is shown in fig.(c) below.



Since the Induced torque is proportional to the product of the above three terms the total Torque speed characteristics of the Motor can be derived by graphical multiplication of the above three plots and is shown in fig(d) below.



The detailed Torque speed characteristics of an a Induction Motor Showing the Starting, Pull-out and Full-load torques are shown in the figure below.



**Fig: Torque speed characteristics of an a Induction Motor Showing the Starting, Pull-out and Full-load torques**

**Speed control of Induction motors - Basic Methods:****Stator side:**

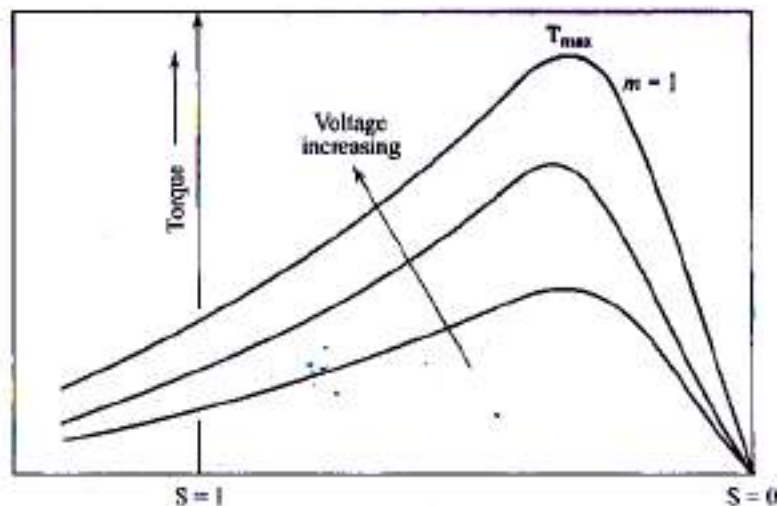
1. Stator Voltage control
2. Stator variable frequency control

**Rotor side:**

- Rotor resistance control
- Slip-energy recovery

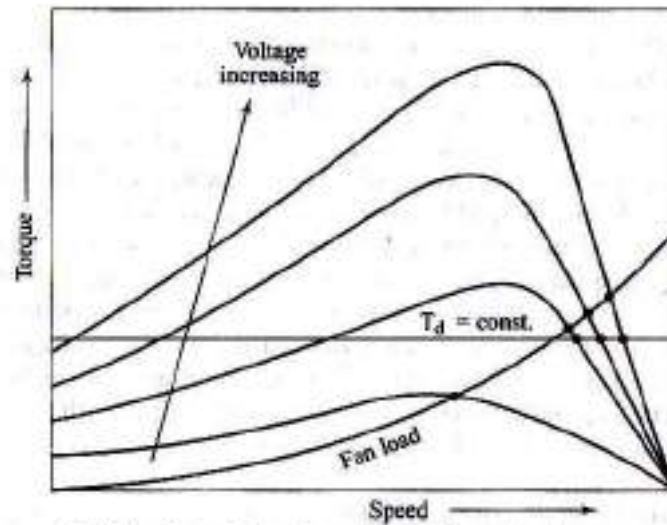
**Stator voltage control:**

- From the expression for the torque developed by an induction motor, we can see that it is directly proportional to the square of the applied terminal voltage at a constant value of supply frequency and slip. By varying the applied voltage, a set of torque-speed curves as shown below can be obtained. When the applied voltage changes by  $n$  times the resulting torque changes by  $n^2$  times.



(a) Typical speed-torque curves for variation in stator voltage (low-resistance rotor)





(b) Operating points and speed range for constant torque and fan type load (rotor resistance low)

- If constant torque is required at different voltages, the slip increases with decreasing voltage to accommodate the required rotor current. But the power factor deteriorates at low voltages.
- Fig(b) shows the torque- speed curves along with a constant load and varying load (with speed ).From this it can be seen that speed control is possible only in a limited range

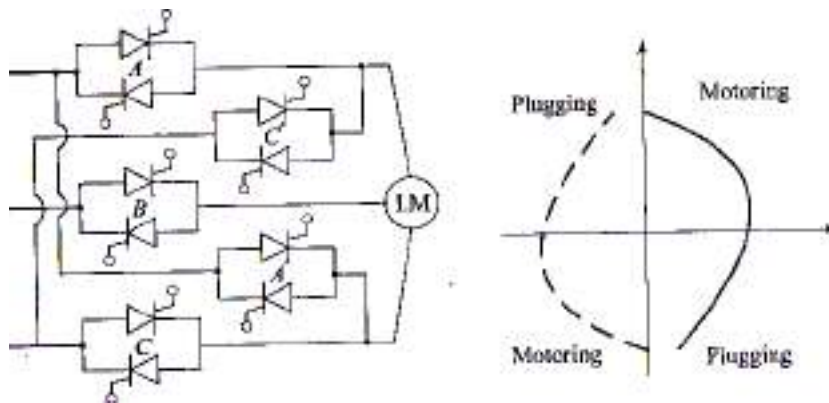
#### Limitations of Stator voltage control:

- The portion of the speed control beyond the maximum torque is unstable and is not suitable for speed control.
- Normal squirrel cage motors will have low rotor resistance and therefore will have a large unstable region. Hence speed control is possible only in a limited band.
- The starting current is also very high for these motors (because of low rotor resistance). Hence the equipment used for control of these motors must be able to handle/withstand such large starting currents.
- The power factor also will be poor at large slips.
- Therefore special rotor design with high resistance is required to be able to take advantage of speed control with stator voltage variation. This shifts the point of slip for maximum torque to the left and decreases the unstable region.
- The unstable region can be reduced or even completely eliminated by properly designing the rotor. This increases the range of speed control substantially, reduces the starting current and improves the power factor.
- However motors designed with high rotor resistance to achieve higher speed control range will have higher rotor losses at large slips and will have to dissipate the resulting large heat in the Rotor itself.
- But slip ring motors allow the insertion of the high resistance externally .Hence the losses will be dissipated in the external resistors only and Rotor heating will be avoided.

**Method of stator voltage control:**

AC voltage controllers can be used for varying the applied input stator voltage. By controlling the firing angle of the thyristors connected in anti parallel in each phase the RMS value of the stator voltage applied to each phase can be varied. To get the desired speed control.

Four quadrant operation with plugging is obtained by the use of the circuit shown in the figure below. Thyristor pairs A,B and C provide operation in quadrants 1 &4 (as shown by the solid line) . Thyristor pairs A',B' and C' changes the phase sequence and thus provide operation in quadrants 2&3 (as shown by the dotted line).

**Precaution:**

While changing from one set to another set of thyristor pairs, i.e from ABC to A'BC' or *vice versa*, care should be taken to ensure that the incoming pair is activated only after the outgoing pair is fully turned off. This is to avoid short circuiting of the supply by the conducting thyristor pairs. Protection against such faults can be provided only by the fuse links and not by the current control.

**Limitations:**

A review of the AC controllers reveals that:

- The output voltage from an AC controller is dependent not only on the delay angle of the gate firing pulses but also on the periods of current flow which in turn are dependent on the load power factor. An induction motor will draw a varying power factor current and this will influence the voltage being applied to it. When ever the load current is continuous, the controller will not have any influence on the circuit conditions at all.
- Control is achieved by distortion of the voltage waveforms and by the reduction of the current flow periods. Significant amounts of stator and rotor harmonic currents will flow and eddy currents will be induced in the iron core. These will cause additional motor heating and alter the motor performance compared with sinusoidal operation.

The practical results of these limitations are:

- The motor performance can be predicted only after a full understanding of the motor, thyristor converter and the load.
- A closed loop speed control based on a tachogenerator speed feedback is essential to ensure stable performance.
- The system gains most practical application when the load is predictable and the load torque required at low speeds is relatively low.

As far as the thyristor ratings are concerned:

- The normal crest working voltage is the peak of the supply line voltage, but high transients can occur if the circuit is opened while in operation by switches or fuses.
- The stored energy in the motor has to be allowed for an assessment of thyristor voltage safety margins and surge suppression requirements.
- The most significant factor in current ratings is the possibility of thyristors having to carry the normal motor starting currents during a period when the thyristors are unable to influence the circuit due to adverse load or power factor conditions.

### Summary:

#### Important concepts and conclusions:

- Induction motor works on the principle of induction from stator rotating magnetic field to the rotor.
- The magnitude of the induced Torque in an Induction motor is given by :

$$T_{ind} = k B_r B_{net} \sin \delta$$

- **The Torque speed characteristic can be divided into three important regions:**

#### 1. Low Slip Region: In this region :

- The motor slip increases approximately linearly with increased load.
- The mechanical speed decreases approximately linearly with increased load.
- Rotor reactance is negligible. So Rotor Power factor is almost unity.
- Rotor current increases linearly with slip.

*The entire normal steady state operating range of an Induction motor is included in this linear low slip region. Thus in normal operation an induction motor has a linear speed drooping characteristic*

#### 2. Moderate slip region: In this region:

- Rotor frequency is higher than earlier and hence the Rotor reactance is of the same order of magnitude as the rotor resistance.
- Tor current no longer increases as rapidly as earlier and the Power factor starts dropping.
- The peak torque( Pull out or Break down Torque) occurs at a point where for an incremental increase in load the increase in the current is exactly balanced by the decrease in rotor power factor.

#### 3. High slip region: In this region:

- The induced torque actually decreases with increase in load torque since the increase in Rotor current is dominated by the decrease in Rotor power factor.

• **Important characteristics of the Induction Motor Torque Speed Curve:**

- Induced Torque is zero at synchronous speed.
- The graph is nearly linear between no load and full load (at near synchronous speeds). In this region the Rotor resistance is much larger than the Rotor reactance, and hence the Rotor Current, magnetic field and the induced torque increases linearly with increasing slip.
- There is a Max. Possible torque that cannot be exceeded which is known as pull out torque or breakdown torque. This is normally about two to three times the full load torque.
- The Starting torque is higher than the full load torque and is about 1.5 times. Hence this motor can start with any load that it handle at full power.
- Torque for a given slip varies as the square of the applied voltage. This fact is useful in the motor speed control with variation of Stator Voltage.
- If the rotor were driven faster than synchronous speed, then the direction of the Induced torque would reverse and the motor would work like a generator converting mechanical power to Electrical power.
- If we reverse the direction of the stator magnetic field, the direction of the induced torque in the Rotor with respect to the direction of motor rotation would reverse, would stop the motor rapidly and will try to rotate the motor in the other direction. Reversing the direction of rotation of the magnetic field is just phase reversal and this method of Braking is known as Plugging

**Speed control of Induction motors - Basic Methods:**

**Stator side:**

- Stator Voltage control
- Stator variable frequency control

**Rotor side:**

- Rotor resistance control
- Slip-energy recovery

**Important formulae and equations:**

- Synchronous speed of rotating magnetic field :  $n_s = 120 \cdot f_s / P$
- Voltage induced in the rotor :  $e_{ind} = (v \times B) l$
- Torque induced in the rotor :  $T_{ind} = k \cdot B_r \times B_s$
- Magnitude of the Torque induced in the Rotor :  $T_{ind} = k B_r B_{net} \sin \delta$
- slip  $s$  on percentage basis:

$$s = \frac{n_{slip}}{n_{sync}} (\times 100\%)$$

$$s = \frac{n_{sync} - n_m}{n_{sync}} (\times 100\%)$$

- Slip  $s$  on per unit basis:  $S = (N_{\text{sync}} - N_m) / N_{\text{sync}}$
- The magnitude of the rotor induced voltage  $E_R$  in terms of the rotor induced voltage at rotor locked condition  $E_{R0}$  :  $E_R = s.E_{R0}$
- The magnitude of the rotor Reactance  $X_R$  in terms of the rotor Reactance at rotor locked condition  $X_{R0}$  :  $X_R = s.X_{R0}$  (since  $f_r = s.f_s$  and  $X_R = s.2\pi f_s L_R$ )
- The rotor frequency can be expressed as :

$$f_r = (P/120) \cdot (n_{\text{sync}} - n_m)$$

- Important relationships between Air gap power  $P_{AG}$ , converted power  $P_{\text{conv}}$ , Rotor induced Torque  $T_{\text{ind}}$ , Rotor copper losses  $P_{\text{rc}}$  and the slip  $s$  :

$$T_{\text{ind}} = P_{\text{conv}} / \omega_m$$

$$T_{\text{ind}} = P_{AG} / \omega_s$$

$$P_{\text{rc}} = s.P_{AG}$$

$$P_{\text{conv}} = (1-s) P_{AG}$$

- Torque developed by the motor  $T_d$ :

$$T_d = \frac{P_{\text{gross}}}{\omega_r} = \frac{P_{\text{gross}}}{\omega_s(1-s)} = \frac{3V_1^2 R_2 / s}{\omega_s [(R_1 + R_2/s)^2 + (X_1 + X_2)^2]}$$

$$\text{or } T_d = \frac{3}{\omega_s} I_2^2 \frac{R_2}{s} \text{ N-m}$$

- Slip at maximum Torque  $S_{\text{max}}$ :

$$S_{\text{max}} = \pm \frac{R_2}{\sqrt{R_1^2 + (X_1 + X_2)^2}}$$

- Maximum developed torque  $T_{\text{max}}$ :

$$T_{\text{max}} = \frac{3V_{1\text{ph}}^2}{2\omega_s [R_1 \pm \sqrt{R_1^2 + (X_1 + X_2)^2}]}$$

- Starting torque  $T_{\text{st}}$  :

$$T_{\text{st}} = \frac{3V_1^2 R_2}{\omega_s [(R_1 + R_2)^2 + (X_1 + X_2)^2]}$$

## UNIT- IV Part 2

### CONTROL OF INDUCTION MOTOR THROUGH STATOR FREQUENCY :

- VARIABLE FREQUENCY CHARACTERISTICS
- VARIABLE FREQUENCY CONTROL OF INDUCTION MOTORS BY VOLTAGE & CURRENT SOURCE INVERTERS AND CYCLOCONVERTERS
- PWM CONTROL
- COMPARISON OF VSI AND CSI OPERATIONS
- SPEED TORQUE CHARACTERISTICS
- NUMERICAL PROBLEMS ON IM DRIVES
- CLOSED LOOP OPERATION OF INDUCTION MOTOR DRIVES( BLOCK DIAGRAMS ONLY)
- SUMMARY:
  - IMPORTANT CONCEPTS AND CONCLUSIONS
  - IMPORTANT FORMULAE AND EQUATIONS

**Variable frequency control:**

In the introduction to Induction motor basics we have seen that the synchronous speed of an induction motor is directly proportional to the supply frequency. Hence by changing the supply frequency the synchronous speed and hence the motor speed can be varied.

When running at speeds below the rated (base) speed of the motor, it is necessary to reduce the terminal voltage applied to the stator along with frequency for proper operation. The terminal voltage applied to the stator should be decreased gradually and linearly with decreasing stator frequency. This process is called derating. To understand the necessity for derating recall that Induction motor can be considered as a rotating transformer and like in any transformer the flux in the core is given by Faradays law as:

$$v(t) = N d\phi/dt$$

Solving for the flux gives:

$$\phi = 1/N \int v(t) dt$$

$$\phi = 1/N \int V_m \sin \omega t dt$$

$$\phi = ( V_m/\omega N ) \cos \omega t$$

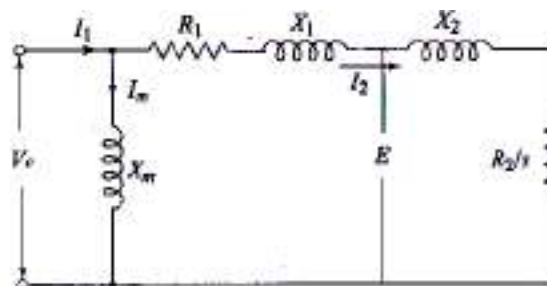
$$\text{i.e. } ( V_m \cos \omega t ) = N.\omega.\phi$$

$$\text{or } v(t) = N.\omega.\phi$$

Where  $v(t)$  is the instantaneous applied voltage. Since  $N$  is a constant the above relation shows that the motor terminal voltage is proportional to the product of the frequency and the flux neglecting the stator voltage drop as we did during the development of the equivalent circuit. From the above expression it can also be seen that any reduction in the supply frequency without a corresponding reduction in the Stator voltage would cause an increase in the air gap flux. Induction motors are designed to operate at the knee point of the magnetisation characteristic to make full use of magnetic core material. Therefore increase in the flux would saturate the core. This will increase the magnetisation current, distort the line current & voltage, increase the core loss & the stator copper loss and produce a higher pitch acoustic noise. While an increase in flux beyond the rated value is not desirable from consideration of the magnetisation aspects, a decrease in flux is also not desirable as it would reduce the torque capability of the motor. ***Hence to avoid excessive magnetisation currents and also to maintain the torque constant variable frequency control below the base speed is normally carried out by reducing the stator voltage along***

**with frequency in such a manner that magnetic flux is maintained constant. This method is called constant V/f control.** But above the base speed, the stator voltage is maintained constant because of the limit imposed by the stator insulation or by supply voltage limitations and hence the developed torque would come down.

**Operation with constant V/f control:** We will study the operation of the motor when the V/f ratio is held constant. We will consider the same simplified equivalent circuit which was used earlier for development of the Torque-speed relations and given below again.



**Fig: Simplified equivalent circuit of an Induction Motor**

From this equivalent circuit, at motor rated terminal voltage ( $V_{\text{rated}}$ ) and rated frequency ( $\omega_{\text{rated}}$ ) we have the expressions for the developed torque and maximum torque as under.

$$T = \frac{3}{\omega_s} \left[ \frac{V_{\text{rated}}^2 (R_2/s)}{(R_1 + R_2/s)^2 + (X_1 + X_2)^2} \right]$$

$$T_{\text{max}} = \frac{3}{2 \omega_s} \left[ \frac{V_{\text{rated}}^2}{R_1 \pm \sqrt{R_1^2 + (X_1 + X_2)^2}} \right]$$

Now a variable  $K$  is defined as  $K = f/f_{\text{rated}}$  where  $f$  is the operating frequency and  $f_{\text{rated}}$  is the rated frequency of the motor. The variable  $K$  is called **per unit frequency**.

Hence when the motor is operated at any frequency  $f$  other than  $f_{\text{rated}}$ , the synchronous speed, terminal voltage and any reactance  $X$  will have the values multiplied by  $K$  as  $K \cdot \omega_s$ ,  $K \cdot V_{\text{rated}}$  and  $K \cdot X$  respectively.

**Operation below the base speed i.e. rated frequency ( $K < 1$ ):**

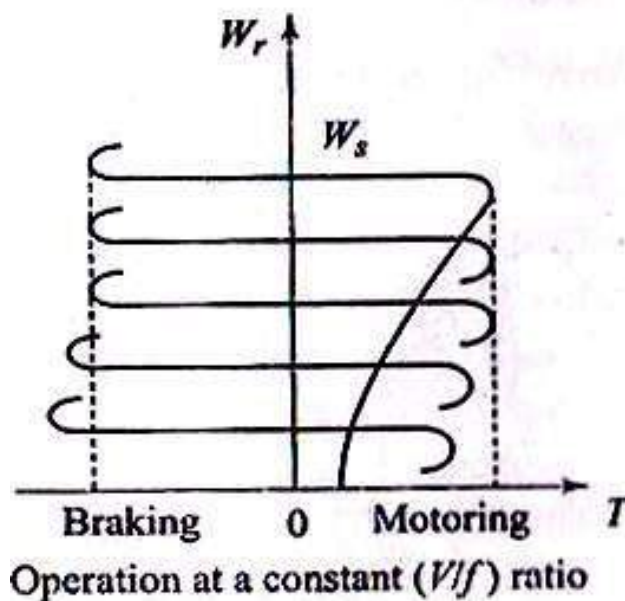
We will first study the operation below the rated frequency. Substituting the values of  $K \cdot \omega_s$ ,  $K \cdot V_{\text{rated}}$  and  $K \cdot X$  in the above expressions for developed torque and the maximum torque we get :



$$T = \frac{3}{\omega_s} \left[ \frac{V_{rated}^2 R_2 / (KS)}{\left(\frac{R_1}{K} + \frac{R_2}{KS}\right)^2 + (X_1 + X_2)^2} \right], K < 1$$

$$T_{max} = \frac{3}{2\omega_s} \left[ \frac{V_{rated}^2}{\left(\frac{R_1}{K}\right) \pm \sqrt{\left(\frac{R_1}{K}\right)^2 + (X_1 + X_2)^2}} \right], K < 1$$

When  $f$  is large,  $(R_1/K) \ll (X_1 + X_2)$  giving an almost constant values for  $T_{max}$  for both motoring and Braking. However for low values of  $f$ , the maximum torque capability is altered. It decreases for motoring and increases for braking as shown in the figure below. The figure below shows the Torque speed characteristics for **constant (V/f)** control and frequency  $f < f_{rated}$



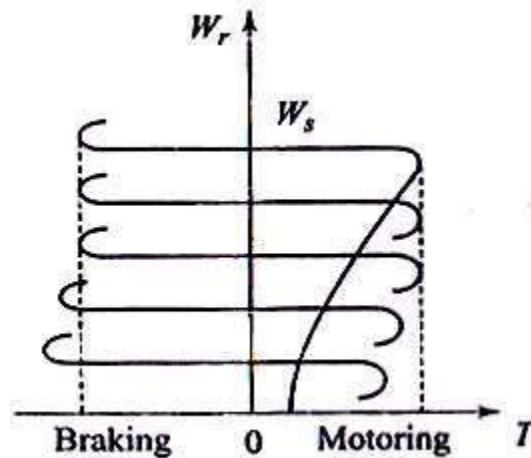
**Fig: Speed- Torque curves with variable frequency & Operation with a constant (V/f) ratio for  $K < 1$**

What is seen for maximum torque is also seen for the rated torque. This behaviour can also be explained from consideration of the magnetic flux.

When the motor operates at frequency with a **constant (V/f)**, the terminal voltages and all reactances are reduced by a factor of  $K$  but the stator resistance remains fixed. The resistance drop which was negligible for high values of  $f$  now become appreciable in comparison with the terminal voltage for low values of  $f$ . As a result the ratio of actual stator voltage with frequency ( $E/f$ ) reduces thus decreasing the magnetic flux and hence the motor Torque capability.

But when working in regenerative braking mode, the rotor current direction is reversed and hence the stator voltage drop has the opposite effect i.e. the flux and the braking torque will have higher values at lower frequencies. This phenomenon can be clearly seen in the figure above.

To make full use of the motor's torque capability at the start and for low speeds, the  $(V/f)$  ratio is increased to compensate for the stator resistance drop at low frequencies. The modified Torque speed characteristics (shown with dotted lines) are shown in the figure below.



**Fig: Torque speed curves with varying  $(V/f)$  control to compensate for stator voltage drop at low frequencies.**

As can be seen the resulting changes are :

- This allows a constant maximum torque to be obtained for motoring operation at all frequencies.
- The braking torque which is already higher at low frequencies increases further. This increase in braking torque may cause severe mechanical stresses on the motor and the load.

**To get a high torque to current ratio, high efficiency and high power factor** the motor is operated for  $S < S_m$  i.e. on the portion of the speed-torque curves with a negative slope. Therefore the figures are shown with only those regions. However a complete characteristic is shown for the rated frequency to provide a comparison between the starting and low speed torque available with variable frequency control and constant frequency operation.

There is a large increase in the starting and low speed torques with a variable frequency control. The corresponding currents are also reduced by a large amount. Thus the starting and low speed performance of a variable frequency drive is far superior compared to that with a fixed frequency operation.

#### **Operation above the base speed i.e rated frequency ( $k > 1$ ):**

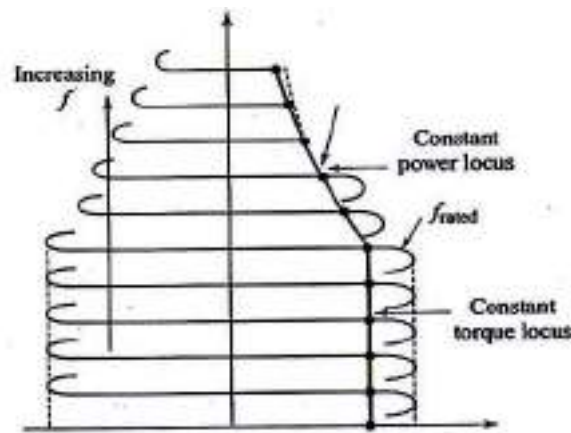
The operation at a frequency higher than the rated frequency (above the base speed) takes place at a constant voltage  $V_{rated}$  or at the maximum voltage available from the variable frequency source if it is less than the  $V_{rated}$ . Since the terminal voltage is maintained constant, the flux decreases in the inverse ratio of the per unit frequency  $K$ . The motor therefore operates in the field weakening mode.

The expressions for Torque in this operating region are obtained by substituting  $K \cdot \omega_s$  for  $\omega_s$ , and  $K(X_1 + X_2)$  for  $(X_1 + X_2)$  in the earlier standard equations as below.

$$T = \frac{3}{\omega_s} \left[ \frac{V_{\text{rated}}^2 R_2 / (KS)}{\left( R_1 + \frac{R_2}{s} \right)^2 + K^2 (X_1 + X_2)^2} \right], K > 1$$

$$T_{\text{max}} = \frac{3}{2\omega_s K} \left[ \frac{V_{\text{rated}}^2}{R_1 \pm \sqrt{R_1^2 + K^2 (X_1 + X_2)^2}} \right], K > 1$$

The Torque-speed curves for operation in the field weakening mode for frequencies above rated frequency along with **constant (v/f)** control for frequencies below rated frequency are shown in the figure below.



**Fig: Speed Torque curves for variable frequency control ( both  $K < 1$  and  $K > 1$  )**

As can be seen:

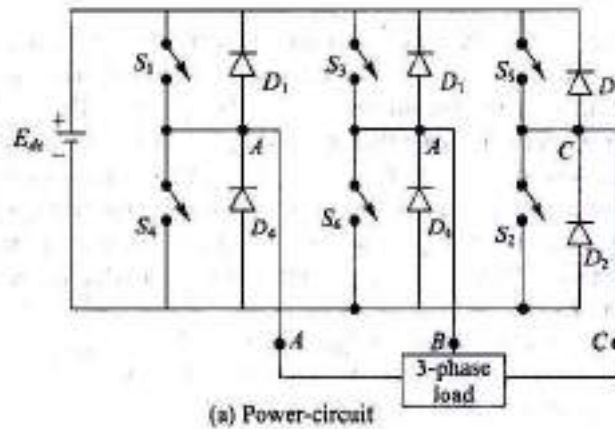
- Since  $K > 1$ , the breakdown torque decreases with the increase in frequency and speed.

*Here also the motor is made to operate with  $S < S_m$  to get high torque per ampere, high efficiency and a good power factor.*

### Three Phase inverters:

Three phase inverters convert the input DC voltage into three phase AC voltages suitable to drive the Induction motors and are an important part of both Voltage Source Inverters and Current Source Inverters (VSIs and CSIs). Several types of Inverters are there to provide a variable voltage and variable frequency output to feed an Induction motor and the most common are the **Quasi Square Wave Inverters** and **Pulse Width modulated inverters (PWM) inverter**.

**Quasi Square Wave Inverters: They are also called Stepped Wave Inverters.** The basic circuit diagram of a three phase Quasi Square Wave Inverter is shown in the figure below.



**Fig: Three phase Bridge Inverter**

It consists of six power switches along with six freewheeling diodes. The switches are periodically switched ON and OFF in a proper sequence to produce the desired three phase output. The rate of switching decides the output frequency of the inverter.

There are two basic methods of gating the switches. (1) 180° gating mode and (2) 120° gating mode. We will explain the operation of a 180° inverter.

*180° Conduction mode Bridge inverter:* The operation of this scheme is briefly explained below along with the operation table and also the waveforms of gating signals and the output Phase & line voltages shown below.

**Table: Operation Table.**

S.No	Interval	Device conducting	Incoming device	Outgoing device
1	I	5, 6, 1	1	4
2	II	6, 1, 2	2	5
3	III	1, 2, 3	3	6
4	IV	2, 3, 4	4	1
5	V	3, 4, 5	5	2
6	VI	4, 5, 6	6	3

- Switches are triggered in the sequence of their numbers 1,2,3,.. at 60° interval.
- Each switch conducts for a period of 180°
- From table it can be seen that in every step of 60° duration three switches are conducting: Two from the top group along with one from bottom group and then two from bottom group along one from top group alternately.
- The three phase voltages  $E_{AN}, E_{BN}, E_{CN}$  are six step waveforms with amplitude of  $E_{DC}/3$  and  $2E_{DC}/3$ . In any duration it will be  $E_{DC}/3$  if two switches from a group are ON and It will be  $2E_{DC}/3$  if one switch from a group is ON. The polarity will be positive if the output is through the closure of any of the top group switches and will be negative if it is through the closure of any of the bottom group switches.

- The three line to line voltages  $E_{AB}, E_{BC}, E_{CA}$  are obtained by taking the difference between the corresponding phase voltages and they are quasi square waveforms with a peak value of  $E_{DC}$  as can be seen in the waveforms.
- Both line and phase voltages are  $120^\circ$  apart. Line voltages  $E_{AB}, E_{BC}$  and  $E_{CA}$  lead phase voltages  $E_{AN}, E_{BN}$  and  $E_{CN}$  by  $30^\circ$

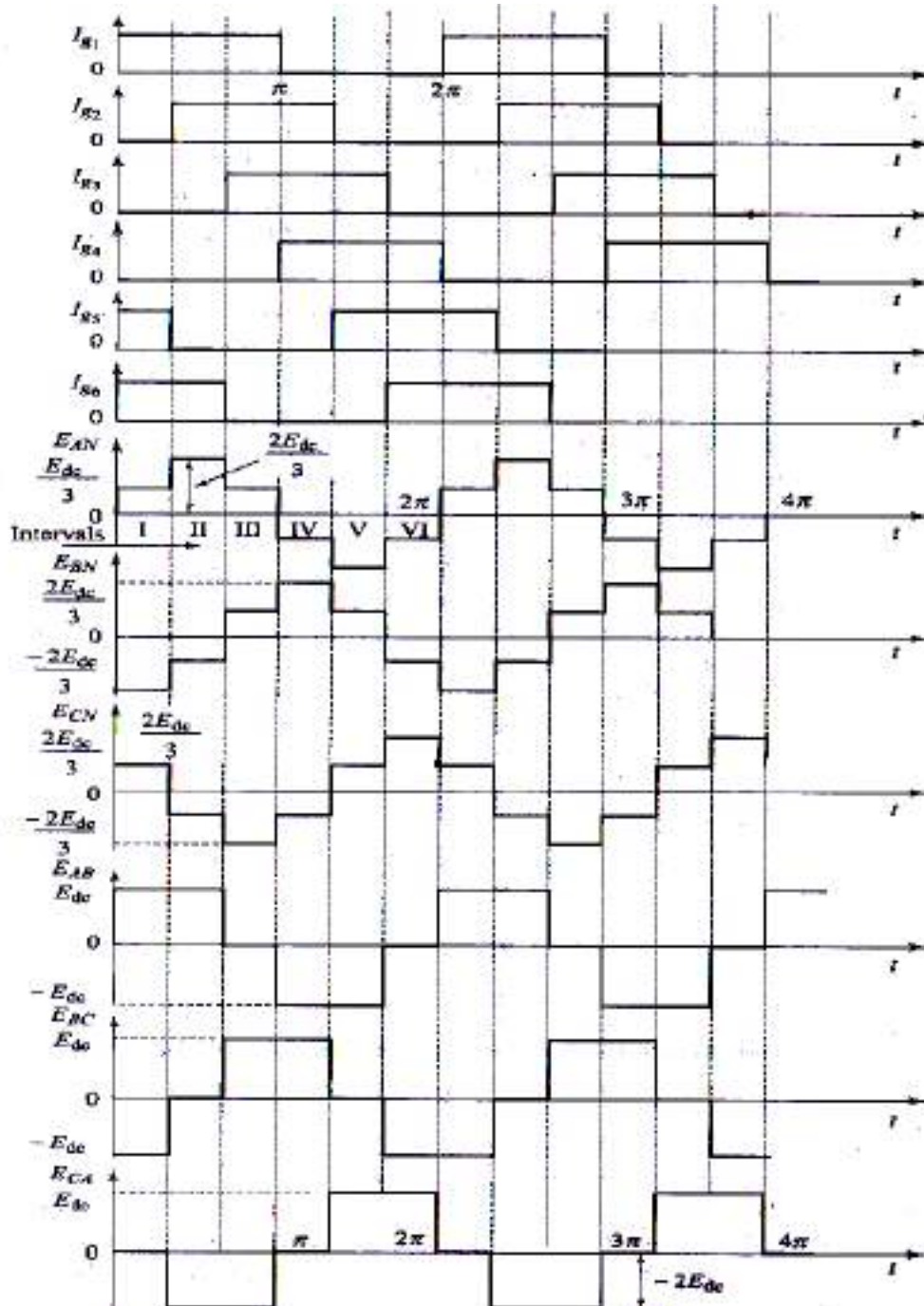


Fig: Voltage waveforms for  $180^\circ$  conduction

### Pulse Width Modulator Inverters:

*Pulse Width Modulation* is the process of varying the width of the pulses in a pulse train in direct proportion to a control signal. The larger the control voltage the wider is the pulse width. By using a sinusoid of the desired frequency as the control signal it is possible to produce a high power waveform whose average voltage varies sinusoidally in a manner suitable for driving the Induction motors.

The basic circuit diagram of a single phase PWM inverter using IGBTs is shown in the figure below. The IGBTs are controlled by the out puts of two comparators A and B. A comparator is a logic circuit which compares the input control voltage  $v_{in}(t)$  with a reference signal and controls the IGBTs. Comparator A compares  $v_{in}(t)$  with reference signal  $v_x(t)$  and controls IGBTs **T1** and **T2**. Similarly comparator **B** compares  $v_{in}(t)$  with reference signal  $v_y(t)$  and controls IGBTs **T3** and **T4**. The comparator logic is designed such that a train of PWM waveforms are generated with both positive and negative voltages across the load such that their instantaneous mean output voltage exactly corresponds to the control voltage.

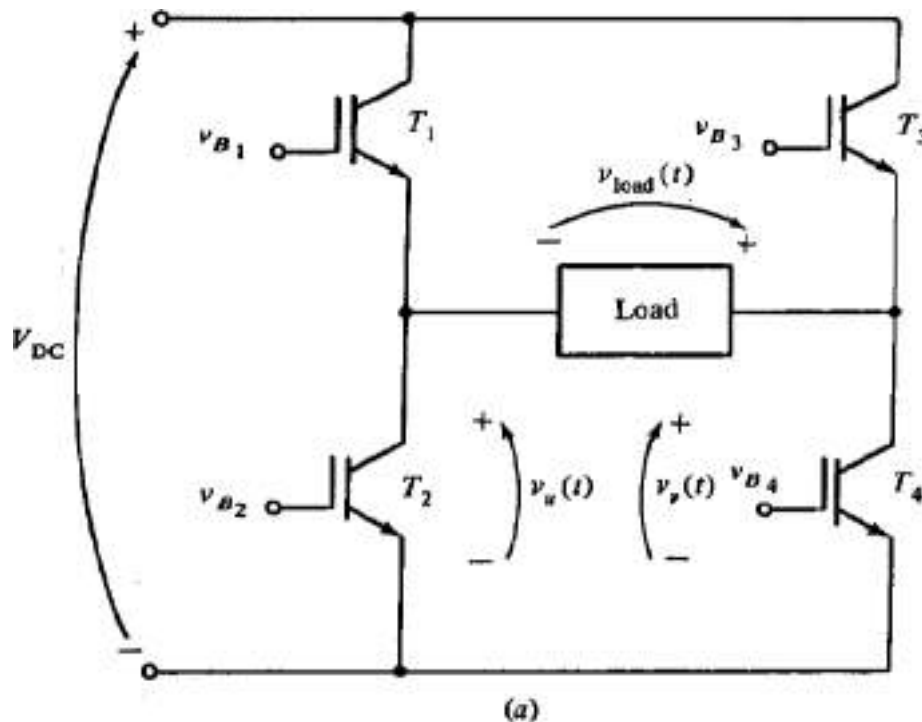
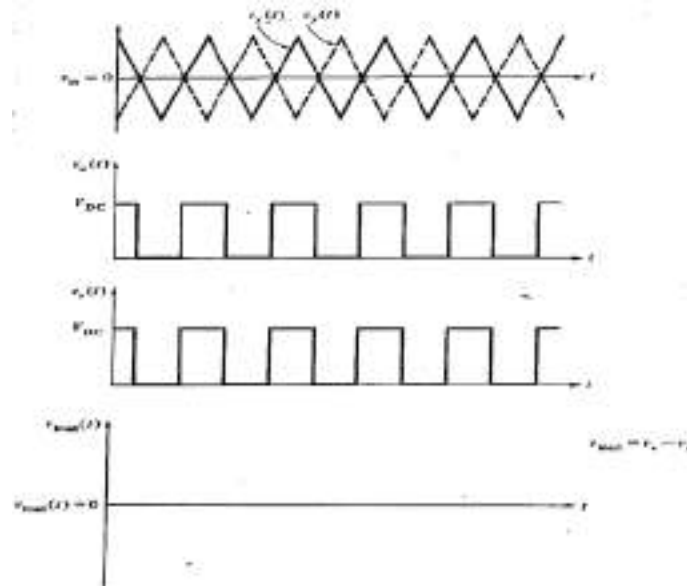


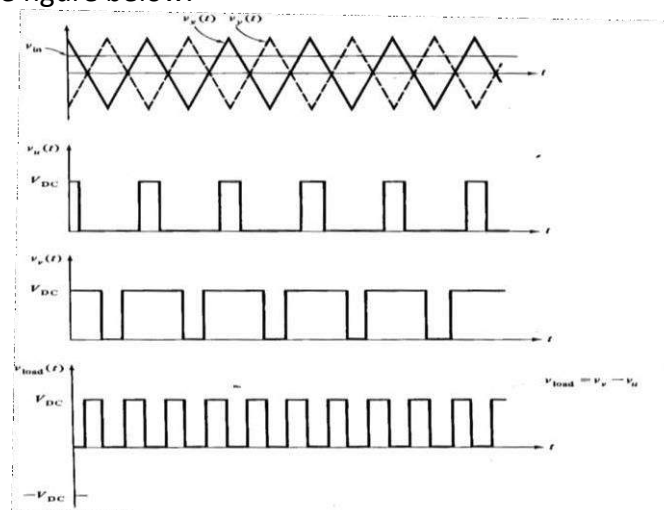
Fig: Basic circuit diagram of a single Phase PWM generator

To understand the overall operation of the PWM Inverter let us see its behaviour with different control voltages. First with control voltage of **0 volts** we find that the two output voltages  $v_u(t)$  and  $v_v(t)$  are equal and the load voltage  $[v_v(t) - v_u(t)]$  is zero. This is shown in the figure below.



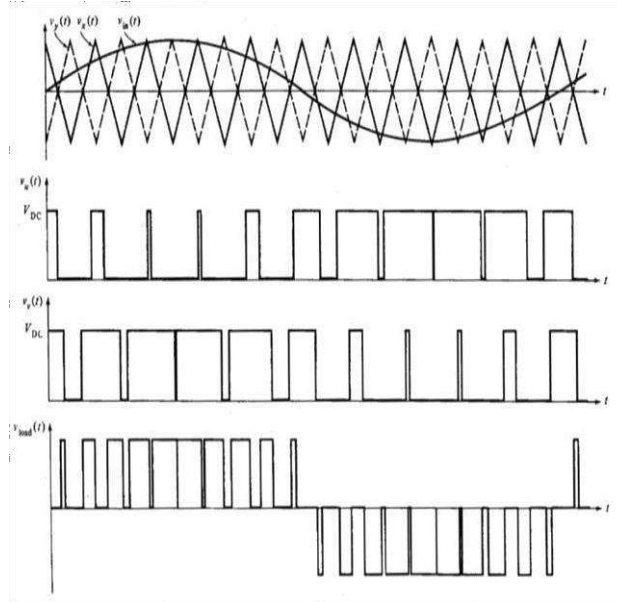
**Fig: The output of the PWM circuit with control voltage equal to 0 volts. Note that  $v_u(t)$  and  $v_v(t)$  are equal and hence the load voltage  $[v_v(t) - v_u(t)]$  is zero.**

Next let us see with a control voltage equal to one half of the peak of the reference voltage. The resulting output voltage across the load is seen to be a train of pulses with 50% duty cycle as shown in the figure below.

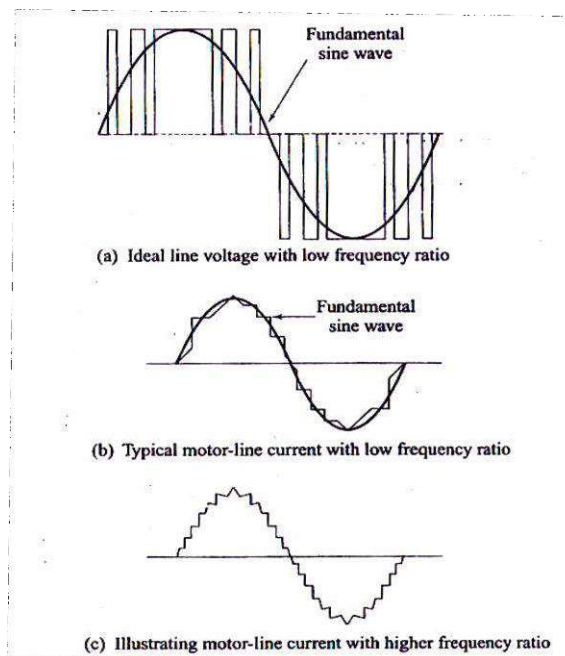


**Fig: The output of a PWM circuit with a control voltage equal to one half of the peak of the reference voltage**

Finally with a sinusoidal control voltage applied to the circuit we can see that the width of the resulting pulse train varies sinusoidally as shown in the figure below. The output is a high power AC waveform whose average output varies just as the input control voltage.



Typical waveforms associated with PWM are shown in the figure below.



**Features and advantages of PWM inverters compared to Quasi Square Wave inverters:**



- 
- Motors will operate quite successfully at high speeds with quasi square wave waveforms but at low speeds the rotating magnetic fields within the machine will be stepped around rather than moving smoothly. Whereas the PWM waveforms allow sinusoidal currents to flow in the motor even at low frequencies giving smooth rotation of the magnetic field and smooth performance of the motor.
  - In PWM Inverters both voltage and frequency can be adjusted allowing the DC link voltage to be maintained constant.
  - The emergence of devices like GTOs, MOSFETs and IGBTs has enabled switching within the inverter to be faster and more efficient thereby eliminating the need for commutating circuits required for conventional thyristors.
  - The frequency ratio is the ratio of the Inverter switching frequency to the Inverter output i.e motor frequency.
  - The current waveforms clearly show the reduction in harmonic current compared to the quasi square wave inverter output since its harmonics are lower as compared to PWM. This explains the desirability to raise the frequency ratio.
  - The choice of the switching frequency in PWM is a compromise between conflicting considerations. Higher the switching frequency the lower is the harmonic content and hence the lower are the conductor losses and smoother is the torque. But the switching losses within the Inverter devices would increase.
  - The magnetic circuit when it has to respond to a high frequency voltage component will show increased magnetic losses and it becomes a source of acoustic noise.
  - Similarly higher switching rate of the Devices would also generate higher levels of acoustic noise.

### **Control of Induction Motors by Voltage Source Inverters:**

An Inverter belongs to the VSI category if looking from the load side the AC terminals of the Inverter function as a Voltage Source. A voltage source has very low internal Impedance and the terminal voltage remains substantially constant with variations in load. Hence it is suitable for both single motor and multi motor drives. Any short circuit across its terminals causes current to rise very fast due to low internal impedance. The fault current cannot be regulated by current control and must be cleared by fast acting fuse links.

In a Voltage source Inverter the DC source is connected to the Inverter through a series Inductor  $L_s$  and a parallel capacitor  $C$ . The capacitance of  $C$  is sufficiently large that the Voltage would almost be constant. The output voltage waveform would be roughly a square wave since voltage is constant and the output current waveform would be approximately triangular. Voltage variations will be small but current can vary widely with variations in load.

The figure below shows the circuit diagram of a VSI employing transistors. Any other self commutating device can also be used instead of transistors. Generally MOSFETs are used in low voltage and low power inverters. IGBTs and power transistors are used up to medium power levels. GTOs and IGCTs (Insulated gate commutated thyristors) are used for high power levels.

VSI can be operated as a stepped wave Inverter or a PWM Inverter. When operated as a stepped wave Inverter, transistors are switched in the sequence of their numbers with a time difference of  $T/6$  and each transistor is kept ON for a period of  $T/2$ . The resultant line voltage is shown in the figure (b) below. Frequency of operation is varied by varying the time period  $T$  and the output voltage of the inverter is varied by varying the DC input voltage.

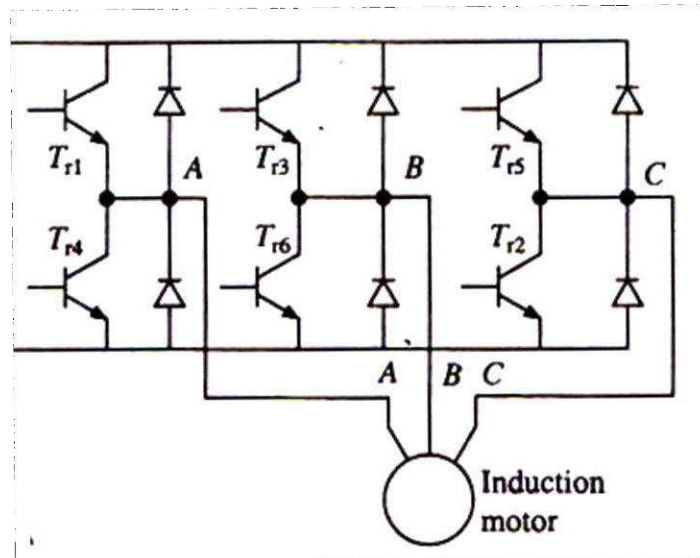


Fig: Circuit Diagram of a Three Phase Voltage Source Inverter

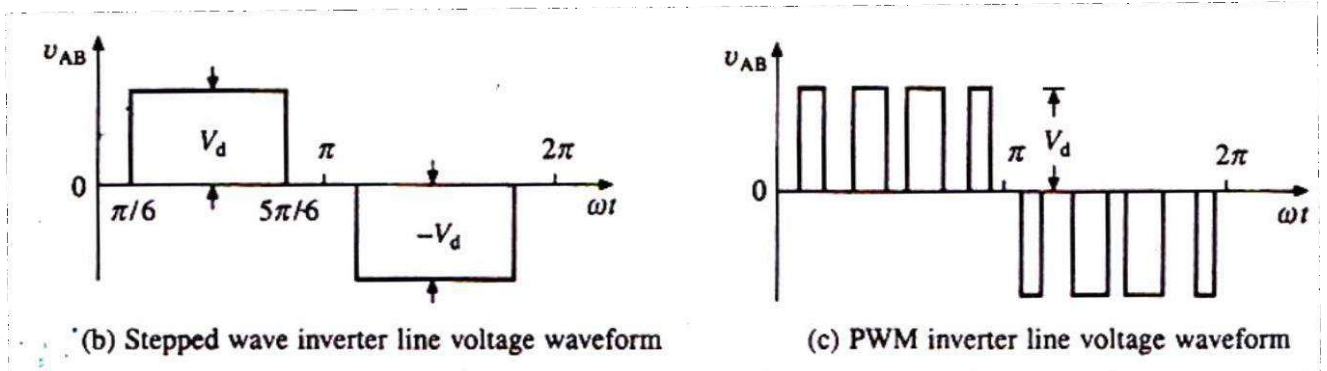
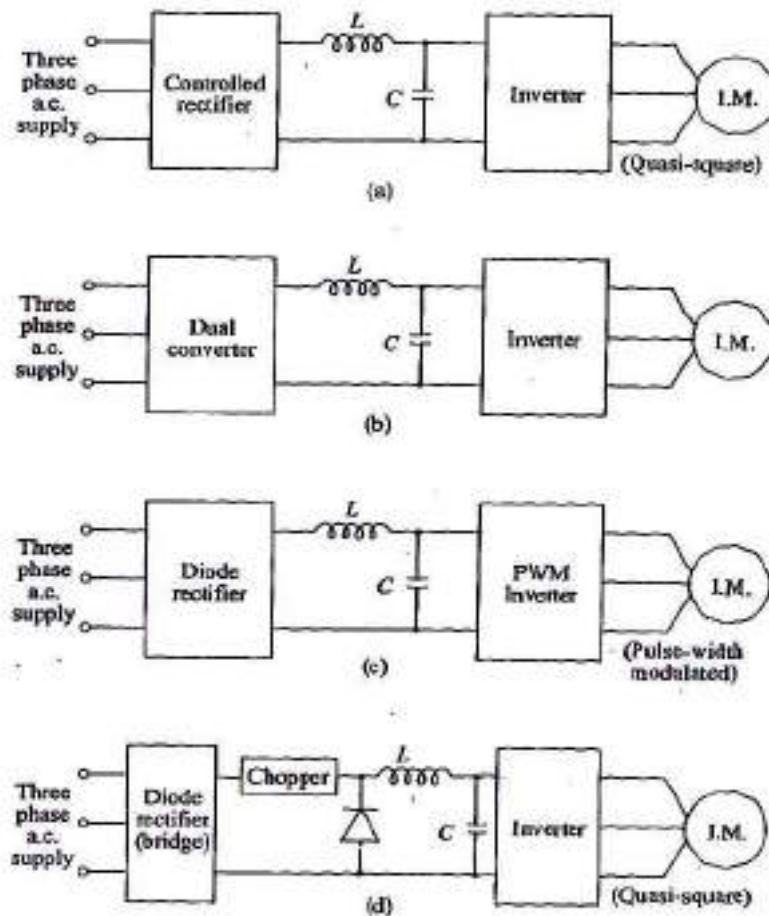


Fig: Stepped wave and PWM Inverter waveforms

The speed of an induction motor can be controlled using a DC or an AC source and four typical schemes of VSIs are shown and explained with the figure below.



**Fig: Schemes for Induction Motor speed control by VSIs**

**(a)** The controlled rectifier varies the DC voltage to the inverter at the same time as the inverter output frequency is varied. The section between the DC source and the Inverter is known as the DC link and it includes a series Inductance and large capacitance which smoothes the DC voltage to an almost constant value,  $E_{DC}$ . In this if the inverter is a six step Inverter the motor voltage is controlled by adjusting the DC link voltage.

**(b)** The above system cannot regenerate since current flow cannot be reversed. If regeneration is required it can be obtained by replacing the phase controlled rectifier with a Dual Converter as shown in figure **(b)**.

**(c)** A system in which the DC link voltage is constant is shown figure **(c)**. In this scheme the Inverter is a PWM based system and it varies both the voltage and the frequency.

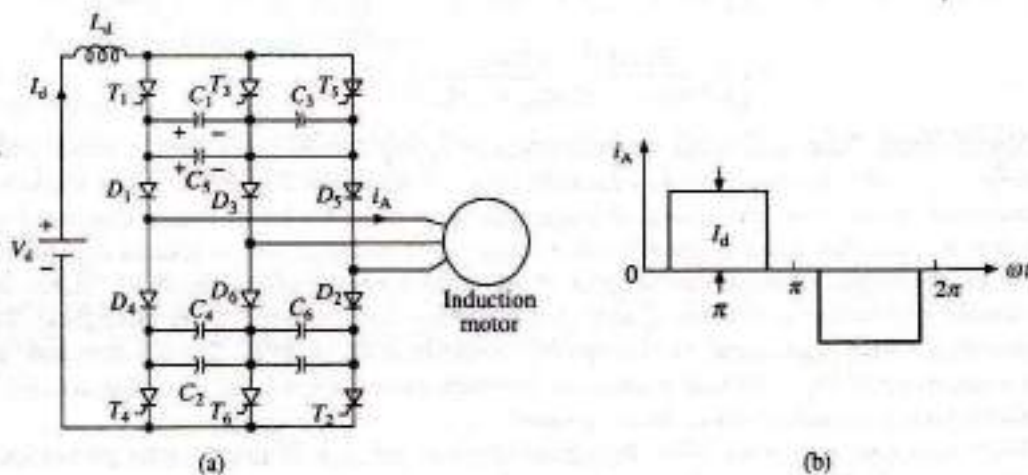
**(d)** In the fourth scheme the variation of voltage is obtained by a chopper. Due to the chopper the harmonic injection into the AC supply is reduced. This scheme is a combination that is used when a high frequency output is required and hence a PWM inverter is not possible.

#### **Control of Induction Motors by Current Source Inverter:**

An Inverter belongs to the CSI category if looking from the load side the AC terminals of the Inverter function as a Current Source. A current source has large internal Impedance and hence the terminal voltage of a CSI changes substantially with change in load. If used in a multi motor drive a change in load would affect the other motor drives and hence a CSI is not suitable for multimotor drives. But since the inverter current is independent of load impedance it has inherent protection against short circuits across its terminals.

In a Current Source Inverter the DC source is connected to the Inverter through a large series Inductor  $L_s$  which would limit the current to be almost constant. The output current waveform would roughly be a square wave since current is constant and the output voltage would be approximately triangular. It is easy to limit the over current conditions in this system but the output voltage can swing widely in response to changes in load conditions.

A thyristor based current source Inverter (CSI) is shown in the figure(a) below. This is a stepped wave inverter whose operation is already explained. Diodes  $D_1$ -  $D_6$  and capacitors  $C_1$ - $C_6$  provide commutation of thyristors  $T_1$ - $T_6$  which are fired with a phase difference of  $60^\circ$  in sequence of their numbers. Figure (b) below shows the nature of output current waveforms. The inverter behaves as a current source inverter due to the presence of the large Inductor in the DC link.



**Fig: (a) Circuit diagram of a Current Source Inverter (b) Current waveform**

The fundamental component of motor phase current from the figure (b) is given by

$$I_s = (\sqrt{6/\pi}) \cdot I_d$$

For a given speed, torque is controlled by varying the DC link current  $I_d$  by changing the value of  $V_d$ . Hence when supply is AC, a controlled rectifier is connected between the supply and Inverter. When the supply is DC a chopper is connected between the supply and Inverter as shown in the figure (b) below. The maximum value of DC output voltage of the fully controlled rectifier and chopper are chosen such that the motor terminal voltage saturates at rated value.

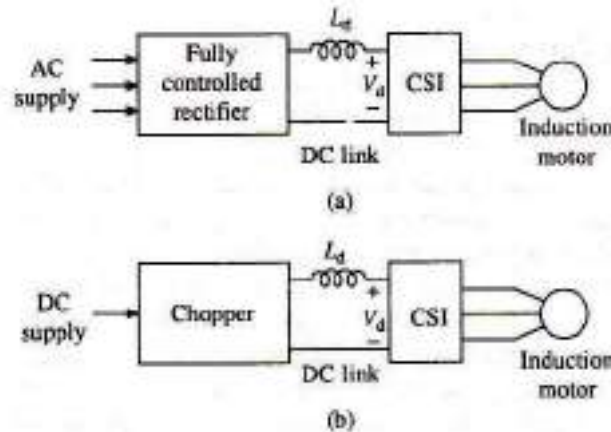


Fig: Different configurations of CSI Induction motor drives.

Comparison of VSIs with CSIs :

	Current source inverter	Voltage source inverter
Main circuit configuration		
Type of source	Current source – $I_s$ almost constant	Voltage source – $V_s$ almost constant
Output impedance	High	Low
Output waveform		
Characteristics	<ol style="list-style-type: none"> <li>1. Easy to control overcurrent conditions with this design</li> <li>2. Output voltage varies widely with changes in load</li> </ol>	<ol style="list-style-type: none"> <li>1. Difficult to limit current due to capacitor</li> <li>2. Output voltage variations small due to capacitor</li> </ol>

- The major advantage of CSI is its reliability. In case of VSIs a commutation failure would cause the switching devices in the same leg to conduct simultaneously. This causes a shorting of the source voltage and hence the current through the devices

would rise to very high levels. Expensive high speed semiconductor fuses are required to be used to protect the devices.

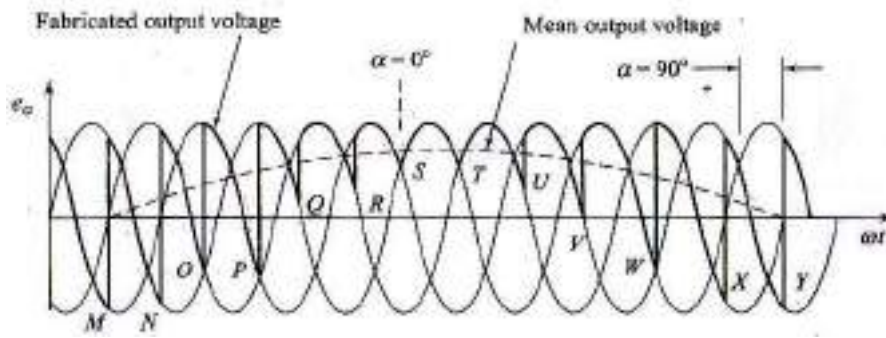
- In case of CSIs simultaneous conduction of two devices in the same leg will not lead to sudden rise of current due to the presence of the large Inductance. This allows time for commutation to take place and normal operation will get restored in the subsequent cycles. Further less expensive HRC fuses are good enough for protection of thyristors.
- As seen in the CSI current waveforms, the motor current rise and fall are vary fast. Such a fast rise and fall of current through the motor leakage Inductance of the motor produces large voltage spikes. Therefore a motor with low leakage reactance is used. Even then voltage spikes could be large. The commutation capacitors C1-C6 reduce the voltage spikes to some extent by limiting the rise and fall of current. But large values of capacitors are required to substantially reduce the voltage spikes. Large values of commutation capacitors have the advantage that cheap converter grade thyristors can be used but then they reduce the frequency range of the inverter and hence the speed range of the drive.
- Further, due to large values of Inductors and capacitors, the CSI drive is expensive and will have more weight and volume.

### **Cycloconverter:**

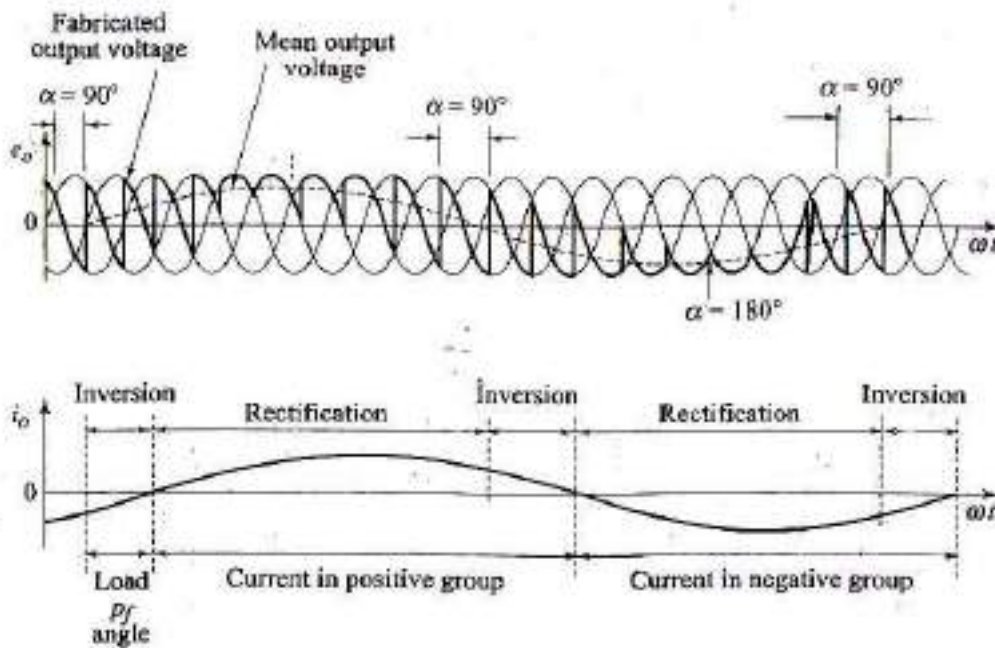
Cycloconverter is a device for directly converting AC power at one frequency to AC power at another frequency. The input to cycloconverter is a three phase source which consists of three AC voltages equal in magnitude and phase shifted from each other by  $120^\circ$ . The output is the desired frequency at the required voltage and power level.

As we know, in a three phase full converter the mean output DC voltage is maximum with a firing angle of  $0^\circ$  and is zero with a firing angle of  $90^\circ$  and is negative maximum with a firing angle of  $180^\circ$ . In between it varies from positive maximum to negative maximum with corresponding firing angle variation. Cycloconverter makes use of this basic principle and generates its output voltage by selecting the combination of the three phases which are made to closely approximate the desired single phase output by varying the firing angle continuously in accordance with a control signal. The control signal is the low level frequency of the desired output.

The synthesized (fabricated )output voltage from the three phases along with the corresponding desired mean output voltage for half cycle and full cycle for one phase are shown in the figure below.

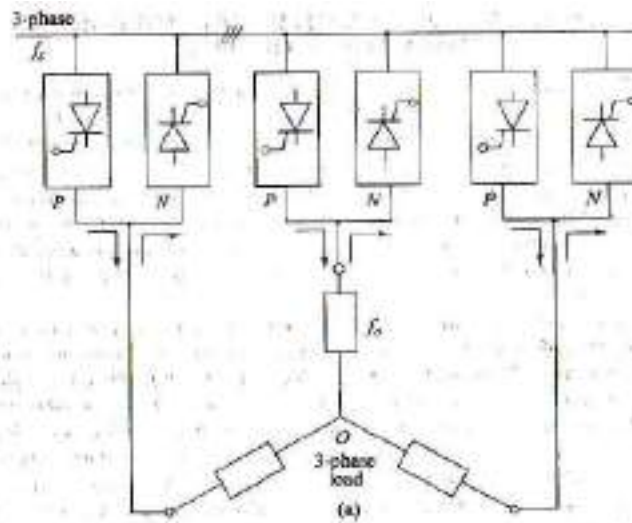


**Fig: Fabricated and mean output voltage waveform for a single phase cycloconverter (half cycle)**

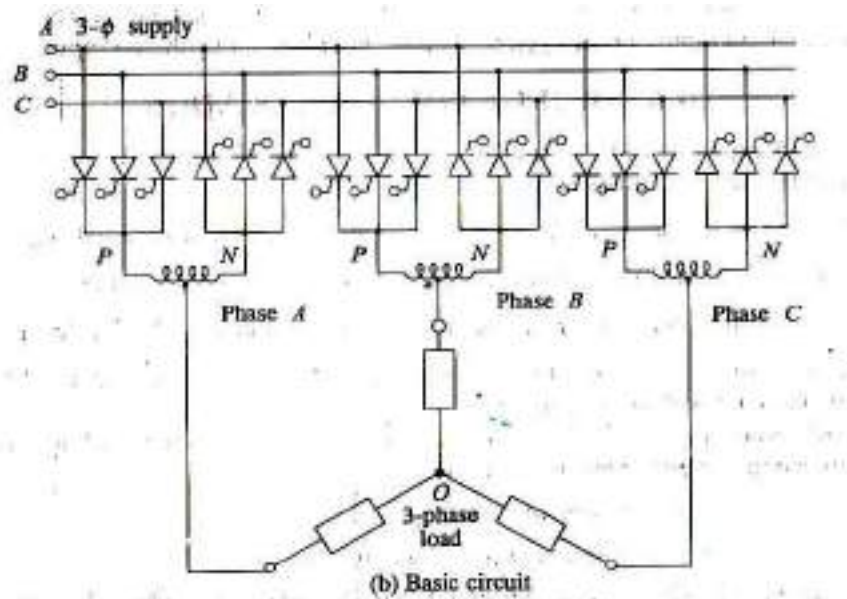


**Fig: Fabricated and mean output voltage waveform for a single phase cycloconverter (full cycle)**

A full three phase cycloconverter is made up of three such cycloconverters connected together as shown in the figure below utilising half wave converters connected in antiparallel in a circulating current mode as shown in the subsequent figures below.



**Fig: Three phase to Three phase cycloconverter Schematic diagram**



**Fig: Three phase to Three phase cycloconverter basic circuit diagram**



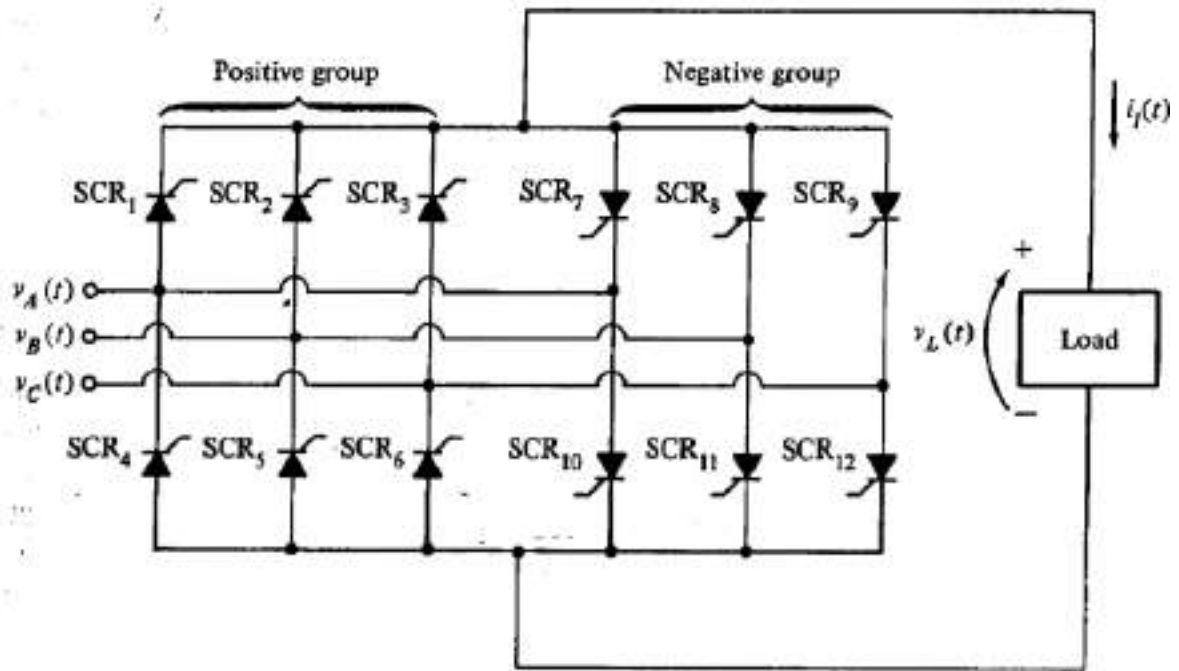


Fig: Non Circulating current cycloconverter

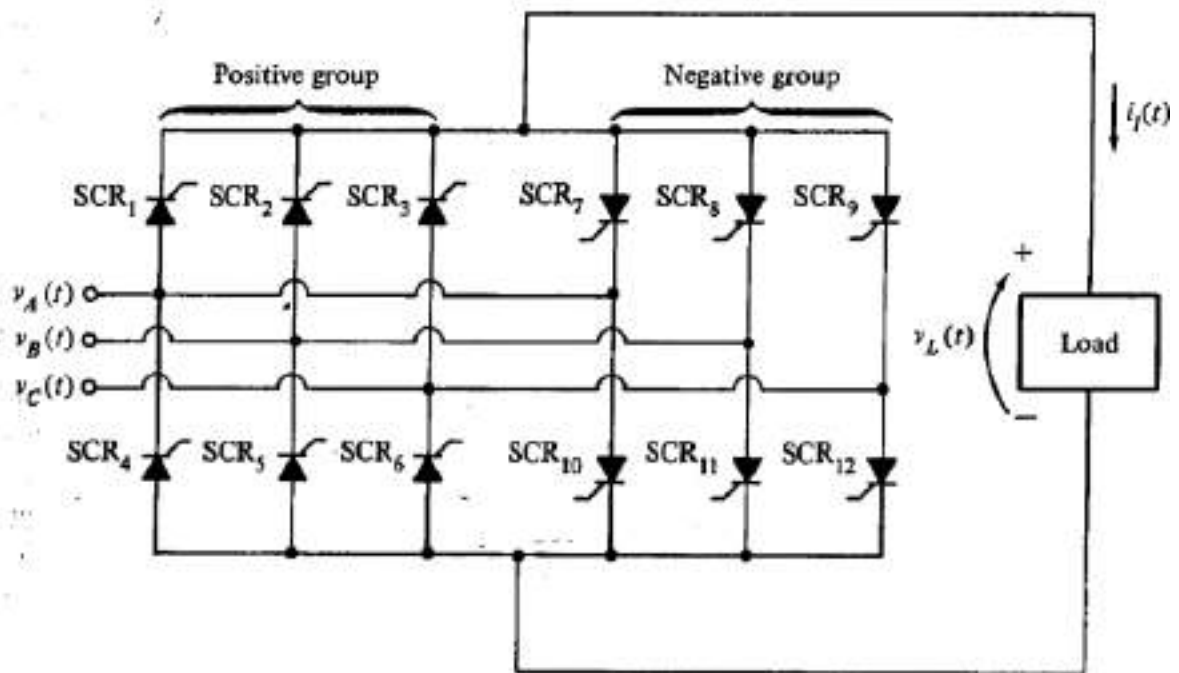


Fig: Circulating current cycloconverter

---

### Cycloconverter

- AC Power at one frequency is converted directly into a lower frequency in a single conversion stage.
- Functions on the principle of phase commutation and no auxiliary commutation circuits are necessary. Results in a compact circuit and also eliminates losses associated with forced commutation.
- Capable of power transfer in either direction between load or the source. Can supply power to loads at any power factor. Capable of regeneration at full power over the complete speed range. This feature makes cycloconverter suitable for large reversing drives requiring rapid acceleration and deceleration.
- Commutation failure causes a short circuit of the AC supply line. But if an individual thyristor fuse blows a complete shutdown is not necessary and the cycloconverter can continue to function with somewhat distorted waveform. A balanced load is presented to the AC supply even with unbalanced output conditions.
- Gives a high quality sinusoidal waveform even at low output frequencies since it is synthesized
- Has two power controllers and the full out power is converted in two stages.
- Requires forced commutation for the inverter even though the rectifier works on the principle of phase control.
- This feature is slightly difficult and is involved to incorporate.
- DC link converter cannot provide this feature.
- Gives a stepped waveform which causes a non uniform rotation at from a large number of segments of the three phase supply. Hence

### DC link converter

---

---

this is often preferable for very low speed applications.

- For a reasonable power output and efficiency the output frequency is limited to about one third of the input frequency.
- Requires a large number of thyristors (36) and its control circuitry is more complex. Not justified for small installations but suitable for units of 20 KVA and more.
- Has a low power factor especially at reduced output voltages.
- Extremely suitable for large power low speed reversing drives.

- The frequency can be varied from zero to rated value. The upper frequency limit is decided by the device switching speed.
- Requires only 12 devices and control circuits are less complex.
- Has high PF with Diode rectifier. With phase controller the PF depends on phase angle.
- Extremely suitable for high frequencies.

low frequencies. The distorted waveform also causes system instability at low frequencies.

**Closed loop speed control with VSI/cycloconverter based Induction Motor drives:**

A closed loop speed control system similar to the one we have studied for a DC motor control is shown in the figure below. It employs a slip speed inner loop and an outer speed loop. Since for a given slip speed current and Torque are constant slip speed inner loop is used in place of inner current loop. Further it ensures that speed of operation is always on that portion of the Speed Torque curve between synchronous speed and the speed at maximum Torque for all frequencies. This ensures high Torque to current ratio. The drive uses a PWM inverter fed from a DC source which has capability for regenerative braking and four quadrant operation. This scheme is applicable to any of the VSI or cycloconverter drives as well which has Regenerative or dynamic braking capability. The closed loop operation is explained below.

The speed error is processed through a PI controller and a slip regulator. PI controller is used to get good steady state accuracy. The slip regulator sets the slip speed command  $\omega^*_{sl}$  whose maximum value is limited to limit the inverter current to a permissible value. The synchronous speed obtained by adding actual speed  $\omega_m$  and slip speed  $\omega^*_{sl}$  determines the inverter frequency. The reference signal for the closed loop control of the machine terminal voltage  $V^*$  is generated from frequency  $f$  using a function generator which ensures a constant flux operation up to base speed and operation at constant terminal voltage above base speed.

A step increase in speed command  $\omega^*_m$  produces a positive speed error. The slip speed command  $\omega^*_{sl}$  is set to the maximum positive value. The drive accelerates at the maximum permissible inverter current producing maximum available torque until the speed error is reduced to a small value. The drive finally settles at a slip speed for which the motor torque balances the load torque.

A step decrease in speed command  $\omega^*_m$  produces a negative speed error. The slip speed command  $\omega^*_{sl}$  is set to the maximum negative value. The drive decelerates under regenerative braking at the maximum permissible inverter current producing maximum available braking torque until the speed error is reduced to a small value. The drive finally settles at a slip speed for which the motor torque balances the load torque.

With this scheme the drive has fast response because the speed error is corrected at the maximum available torque. Direct control of slip assures stable operation under all operating conditions.

For operation above base speed, the slip speed limit of the slip regulator must be increased linearly with the frequency until the breakdown torque value is reached. This is achieved by adding to the slip regulator output an additional slip speed signal proportional to frequency and of appropriate sign. For frequencies higher than the frequency for which the breakdown torque is reached, the slip speed limit is kept fixed near the breakdown value.

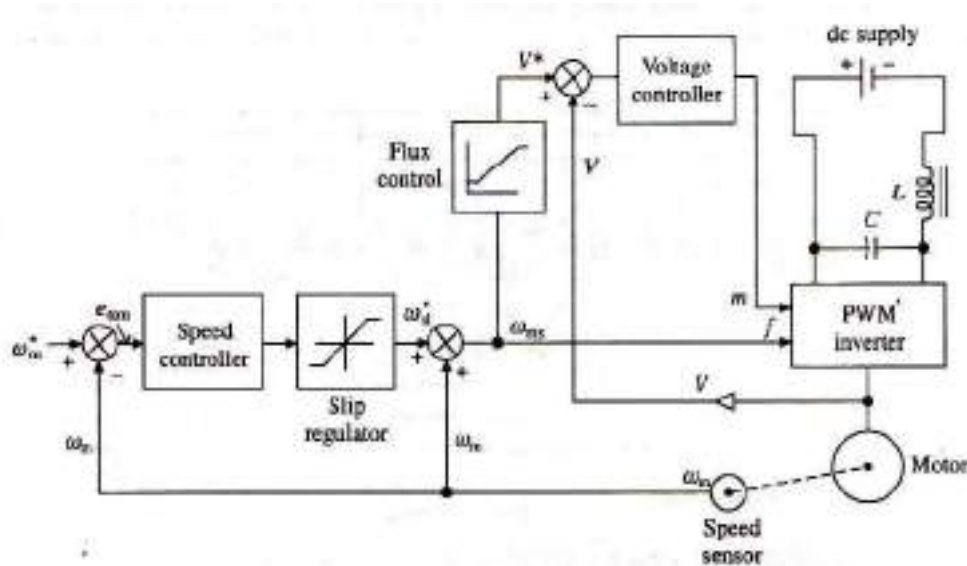


Fig.: Closed loop slip controlled VSI Induction motor drive with PWM inverter.

### Summary:

#### Important concepts and conclusions:

- Synchronous speed of an induction motor is directly proportional to the supply frequency. Hence by changing the supply frequency the synchronous speed and hence the motor speed can be varied.
- The motor terminal voltage is proportional to the product of the frequency and the flux neglecting the stator voltage drop as given by the relation:  $v(t) \propto \omega \cdot \phi$ . Hence any reduction in the supply frequency without a corresponding reduction in the stator voltage would cause an increase in the air gap flux and a corresponding increase in the magnetisation current which is not desirable.
- Hence to avoid excessive magnetisation currents and also to maintain the torque constant variable frequency control below the base speed is normally carried out by reducing the stator voltage along with frequency in such a manner that magnetic flux is maintained constant. This method is called constant V/f control. But above the base speed, the stator voltage is maintained constant because of the limit imposed

by the stator insulation or by supply voltage limitations and hence the developed torque would come down.

- The resistance drop which was negligible for high values of  $f$  becomes appreciable in comparison with the terminal voltage for low values of  $f$ . As a result the ratio of actual stator voltage with frequency ( $E/f$ ) reduces thus decreasing the magnetic flux and hence the motor Torque capability.
- But when working in regenerative braking mode, the rotor current direction is reversed and hence the stator voltage drop has the opposite effect i.e. the flux and the braking torque will have higher values at lower frequencies.
- To make full use of the motor's torque capability at the start and for low speeds, the ( $V/f$ ) ratio is increased to compensate for the stator resistance drop at low frequencies.
- The two important systems of Induction motor speed control using variable frequency are Voltage Source Inverters(VSI) and Current Source Inverters(CSI).
- The important type of Inverters used in these systems are Quasi Square Wave Inverters(QSW), Pulse Width Modulated Inverters(PWM) and cycloconverters.

#### Important formulae and equations:

- **Normal Torque –Speed relations**

- Torque developed by the motor  $T_d$ :

$$T_d = \frac{P_{\text{gross}}}{\omega_r} = \frac{P_{\text{gross}}}{\omega_s(1-s)} = \frac{3V_1^2 R_2 / s}{\omega_s [(R_1 + R_2/s)^2 + (X_1 + X_2)^2]}$$

$$\text{or } T_d = \frac{3}{\omega_s} I_2^2 \frac{R_2}{s} \text{ N-m}$$

- Slip at maximum Torque  $S_{\text{max}}$ :

$$S_{\text{max}} = \pm \frac{R_2}{\sqrt{R_1^2 + (X_1 + X_2)^2}}$$

- Maximum developed torque  $T_{\text{max}}$ :

$$T_{\text{max}} = \frac{3V_{1\text{ph}}^2}{2\omega_s [R_1 \pm \sqrt{R_1^2 + (X_1 + X_2)^2}]}$$

- Starting torque  $T_{\text{st}}$ :

$$T_{\text{st}} = \frac{3V_1^2 R_2}{\omega_s [(R_1 + R_2)^2 + (X_1 + X_2)^2]}$$

- **Torque –Speed relations below the base speed i.e. rated frequency ( $K < 1$ ):**

- The expressions for Torque in this operating region are obtained by substituting  $K\omega_s$  for  $\omega_s$ ,  $KV_{rated}$  for  $V_{rated}$  and  $K(X_1+X_2)$  for  $(X_1+X_2)$  in the standard equations as below.

$$T = \frac{3}{\omega_s} \left[ \frac{V_{rated}^2 R_2 / (KS)}{\left(\frac{R_1}{K} + \frac{R_2}{KS}\right)^2 + (X_1 + X_2)^2} \right], K < 1$$

$$T_{max} = \frac{3}{2\omega_s} \left[ \frac{V_{rated}^2}{\left(R_1/K\right) \pm \sqrt{\left(R_1/K\right)^2 + (X_1 + X_2)^2}} \right], K < 1$$

- **Torque –Speed relations above the base speed i.e rated frequency (k>1):**

- The expressions for Torque in this operating region are obtained by substituting  $K\omega_s$  for  $\omega_s$ , and  $K(X_1+X_2)$  for  $(X_1+X_2)$  in the standard equations as below. (Note that here  $V_{rated}$  is not changed as it is maintained constant.)

$$T = \frac{3}{\omega_s} \left[ \frac{V_{rated}^2 R_2 / (KS)}{\left(R_1 + \frac{R_2}{s}\right)^2 + K^2 (X_1 + X_2)^2} \right], K > 1$$

$$T_{max} = \frac{3}{2\omega_s K} \left[ \frac{V_{rated}^2}{R_1 \pm \sqrt{R_1^2 + K^2 (X_1 + X_2)^2}} \right], K > 1$$

## UNIT-V

### SYLLABUS/CONTENTS:

#### CONTROL OF INDUCTION MOTORS FROM ROTOR SIDE :

- Static Rotor Resistance Control
- Slip Power Recovery
- Static Scherbius Drive
- Static Kramer drive
  - Their Performance
  - Speed -Torque Characteristics
  - Advantages
  - Applications
  - Problems
- Summary
  - Important concepts and conclusions

#### CONTROL OF SYNCHRONOUS MOTORS :

- Introduction
- Separate control and self control of Synchronous Motors
- Operation of Self controlled Synchronous Motors by VSI and CSI cycloconverters
- Load commutated CSI fed Synchronous Motor:
  - Operation , Waveforms
  - Speed- Torque Characteristics
  - Applications & Advanatges
  - Numerical problems
- Closed loop operation of Synchronous motor drives (Block Diagram only)
- Variable frequency control, Cyclo converter, PWM, VFI, CSI (As per R17 to be added New )
- Summary
  - Important concepts and conclusions
  - Important formulae and equations

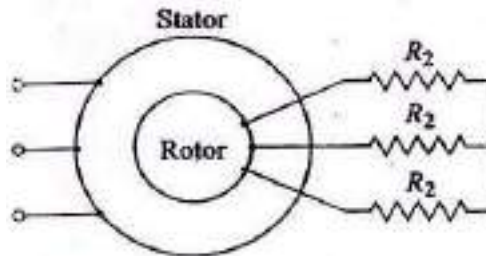
#### Static Rotor resistance control:

---



**Introduction to Rotor Resistance Control:**

Before explaining the static Rotor resistance control a brief introduction to the basic method of **Rotor resistance control** is given here. The speed of an Induction motor can be controlled by the introduction of an external resistance in the Rotor circuit as shown in the figure below.



**Fig: External Rotor resistances connected in a Slip Ring Induction Motor**

The speed-Torque characteristics of an Induction motor with such a control are shown in the figure below. Before studying /analyzing these characteristics, the basic Torque speed relations in an induction motor what we have learnt earlier are given here for a quick reference.

- Torque developed by the motor  $T_d$ :

$$T_d = \frac{P_{\text{gross}}}{\omega_r} = \frac{P_{\text{gross}}}{\omega_s(1-s)} = \frac{3V_1^2 R_2 / s}{\omega_s [(R_1 + R_2/s)^2 + (X_1 + X_2)^2]}$$

or  $T_d = \frac{3}{\omega_s} I_2^2 \frac{R_2}{s} \text{ N-m}$

- Slip at maximum Torque  $S_{\text{maxT}}$ :

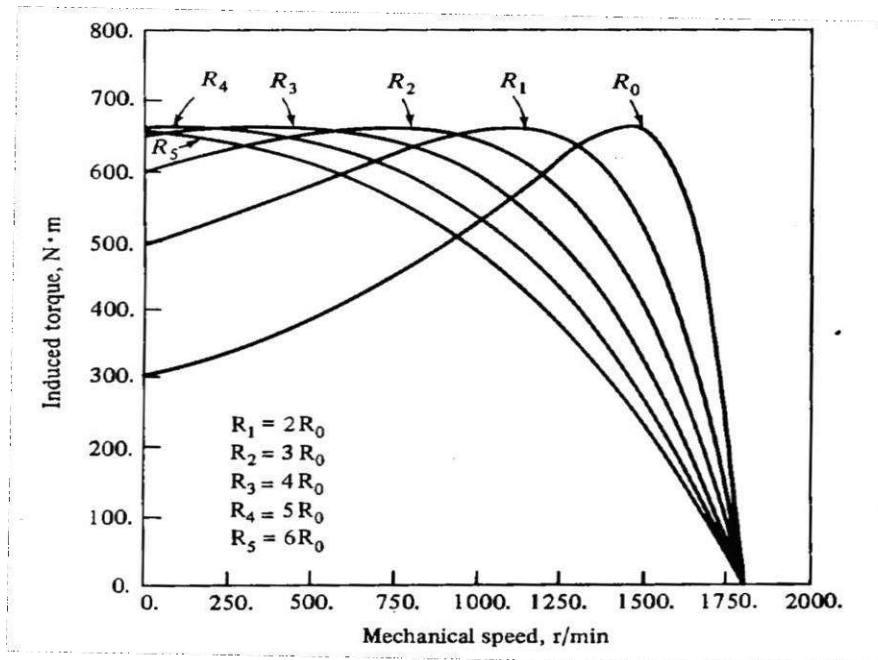
$$S_{\text{maxT}} = \pm \frac{R_2}{\sqrt{R_1^2 + (X_1 + X_2)^2}}$$

- Maximum developed torque  $T_{\text{max}}$ :

$$T_{\text{max}} = \frac{3V_{1\text{ph}}^2}{2\omega_s [R_1 \pm \sqrt{R_1^2 + (X_1 + X_2)^2}]}$$

- Starting torque  $T_{\text{st}}$ :

$$T_{\text{st}} = \frac{3V_1^2 R_2}{\omega_s [(R_1 + R_2)^2 + (X_1 + X_2)^2]}$$



**Fig: Induction Motor Torque-Speed Characteristics with variation of Rotor Resistance.**

A study of the above relations along with the characteristics shows that:

- For a given Load torque, the motor speed is reduced (since slip  $s$  Increases) as the Rotor resistance is increased. However the no load speed remains the same with the variation of the Rotor Resistance.
- The increase in rotor resistance does not affect the value of the maximum Torque but increases the value of Slip at which it occurs.
- With increase in Rotor resistance the starting torque increases and the starting current reduces. Hence the **Torque to current ratio** improves.

*Advantages and disadvantages of Rotor resistance control:*

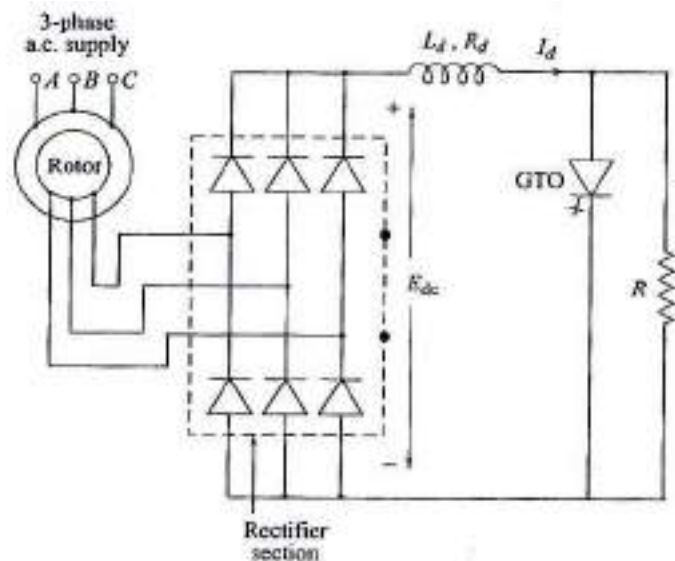
- External resistors can be added only during the accelerating period to increase the starting torque and can be removed later during the steady state. This minimises the losses with dissipation in external resistors.
- The rotor temperature rise is substantially lower than it would have been if the higher resistance were incorporated in the rotor winding as in the case of squirrel cage motors. This allows the optimum utilisation of the motor torque capabilities.
- It provides a constant torque operation with high Torque to current ratio.

- Though Rotor copper losses increase with decrease in speed most of it is dissipated in the external resistors. The copper losses inside the motor remains constant for a given fixed torque. Because of this, a motor of smaller size can be employed.
- **Motor efficiency decreases and the rotor copper losses increase with the decrease in speed. This is the main disadvantage and hence to overcome this, static Rotor resistance control is adopted.**

### Static Rotor Resistance control with a Chopper:

Instead of mechanically varying the Rotor Resistance or electrically by using contactors it can be varied by using a chopper as shown in the figure below. This gives stepless and smooth variation of Resistance and hence the Speed of the motor. In this system the external resistor is introduced in the rotor circuit after converting the slip power into DC using a three phase bridge rectifier instead of directly connecting in the rotor circuit. Along with the resistor a chopper is also connected in parallel. By switching the chopper ON and OFF at a high frequency the effective value of the Resistance is controlled smoothly. As  $T_{on}$  is changed from 0 to its full time period of  $T$  the resistance changes from  $R$  to  $0$ . In terms of the duty ratio  $\delta$  of the Chopper the effective value of the resistance  $R_E$  introduced into the Rotor is given by :

$$R_E = (1 - \delta).R$$



**Fig: Induction Motor Speed control using a chopper**

A filter inductor  $L_d$  is provided in series between the rectifier and the external resistor to smoothen the current  $I_d$ . A high ripple in  $I_d$  produces a high harmonics in the rotor current and hence the rotor copper losses will increase. The diode bridge is the main contributor for the ripple and not the Chopper Switch since it operates at relatively higher frequency.

The Diode Bridge output  $E_{DC}$  changes from its maximum value at standstill to about 5 % at near motor rated speed. Here a Thyristor is not suitable as a Switch since reliable commutation at a higher switching frequency can be obtained only by external commutating circuits which would be bulky and expensive.

The DC voltage  $E_{DC}$  is small because Induction motors are usually designed with stator to Rotor turns ratio of greater than 1. Hence a Transistor switch is good enough for low power drives and GTO can be used for ratings beyond the capability of Transistors. Self commutation capability of these devices ensures reliable commutation and at all operating points and makes the Semiconductor switch compact.

### Slip Power Recovery:

We have seen that In the Rotor resistance control method the slip power which increases with decreasing speed gets dissipated in the resistance and hence the efficiency of the system gets reduced at lower speeds. The mechanical power that can be obtained from the Air gap power is with a per unit conversion efficiency of  $(1-s)$  and the overall motor efficiency would still be lesser than this. The Air gap power is almost totally dissipated as heat in the Rotor circuits at lower speeds and hence the efficiency would be very poor. Therefore the Rotor resistance method of speed control is very inefficient except for a very small speed range close to the synchronous speed.

However instead of dissipating the slip power in the resistance, if it can be conveniently returned to the mains or effectively utilized to increase the drive power then the Drive system becomes more efficient. This is achieved by means of two widely used *slip power recovery* methods known as **Scherbius** and **Kramer** drives. They are also called as cascade drives.

In the traditional **Scherbius** drive shown in the figure below a rotary converter rectifies the slip power and the rectified output drives a DC motor which is coupled to a squirrel cage Induction Generator. The Induction generator is driven at super synchronous speeds and returns the slip power to the same mains supply which gives supply to the Induction motor drive.

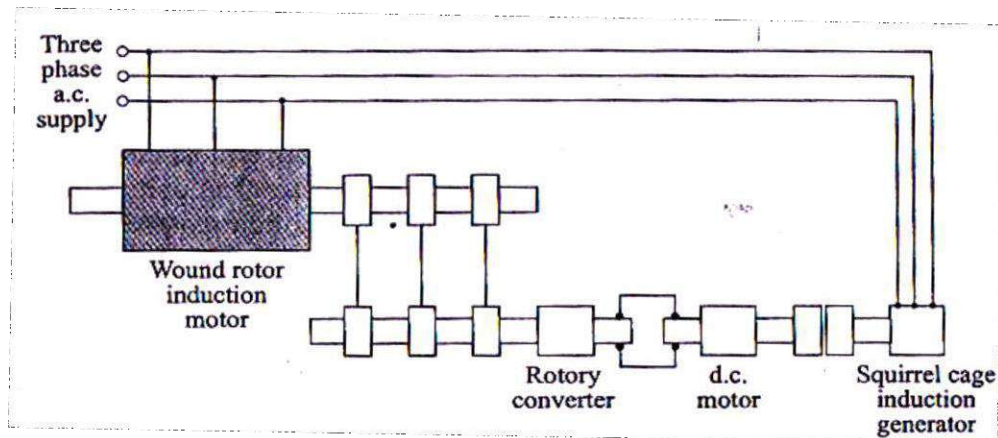


Fig: Traditional Scherbius drive.

In the traditional Kramer drive also the slip power is rectified by a Rotary converter and the rectified output drives a DC motor but it is coupled mechanically directly to the main Induction Motor which aids in generating mechanical power.

These basic methods of slip power recovery by cascading connections are effectively equivalent to Speed control by external e.m.f injection into the rotor circuit. Assume that the motor is operating normally at a slip  $s$ , and an external voltage is applied to the rotor through slip rings in phase opposition to the rotor e.m.f, then the resultant decrease in rotor current reduces the motor torque. This results in an increase in the slip due to the braking action of the load torque. However this increase in slip causes an increase in the induced rotor voltage and hence the rotor current and hence an increase in the rotor torque. This closed loop operation finally establishes a stable operation at a reduced speed when the motor torque just equals the load torque. But in this system the main problem is providing a suitable e.m.f source in which the frequency of the injected source is same as that of the rotor slip frequency.

This problem is eliminated by using static frequency converters/inverters in place of the auxiliary machines used in the traditional cascade drives.

#### Static Scherbius drive:

The static **Scherbius** drive system for the speed control of a wound rotor Induction motor is shown in the figure below. This is also known as sub synchronous converter cascade since it is capable of providing speed control only in the sub synchronous speed range..

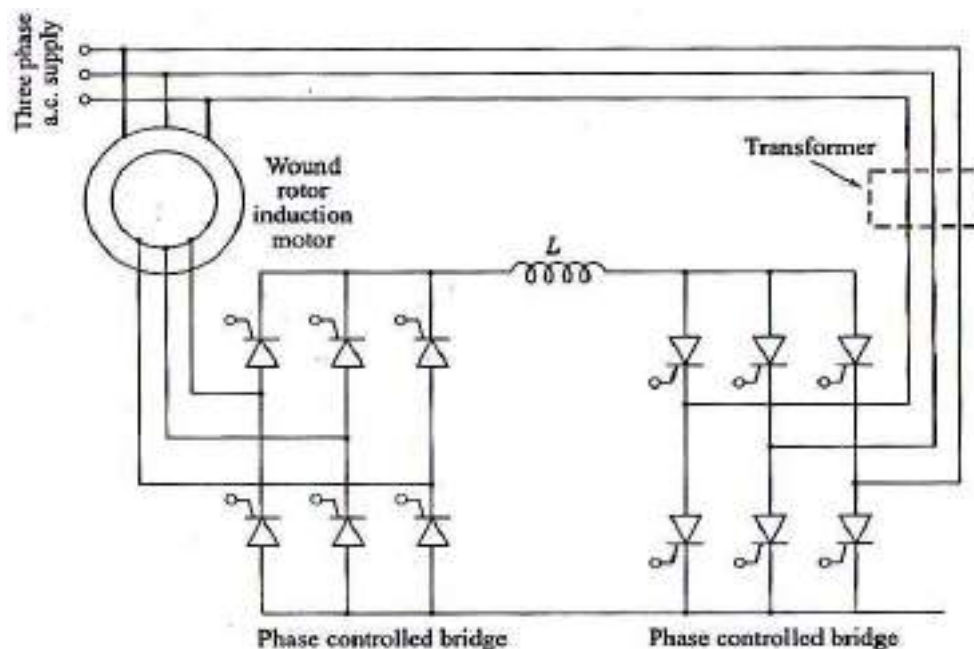


Fig: Static Scherbius drive

The DC link converter consists of a three phase diode bridge rectifier which operates at slip frequency and feeds the rectified slip power to a phase controlled three phase Inverter through a smoothing Inductor. The inverter returns the rectified slip power to the AC supply. The rectifier and the inverter are both naturally commutated by the alternating e.m.fs appearing at the slip rings of the rotor circuit and supply bursars respectively. The problem of matching the frequencies of the injected e.m.f and the rotor e.m.f is eliminated by rectifying the rotor voltage and using the variable back e.m.f available from the controlled three phase inverter as the externally injected speed control voltage.

If commutation overlap is negligible the DC output voltage of the uncontrolled three phase rectifier is given by :

$$E_{DC} = 1.35 E_r s$$

Where  $E_r$  is the line to line Rotor voltage at stand still and  $s$  is the *fractional slip* ( per unit slip )

For a line commutated three phase bridge inverter with negligible commutation overlap the average back e.m.f is given by:

$$E_i = 1.35 E_L \cos \alpha$$

Where  $\alpha$  is the inverter firing angle ( $\alpha > 90^\circ$ ) and  $E_L$  is the AC line to voltage.

Neglecting the drop across the inductor,

$$E_{DC} + E_i = 0 \quad \text{or} \quad 1.35 E_r s + 1.35 E_L \cos \alpha = 0$$

$$\text{And hence } s = - ( E_i / E_r ) \cos \alpha = a |\cos \alpha|$$

Where  $a = (E_L / E_r)$  is the effective stator to rotor turns ratio of the motor. Therefore speed control is obtained by simple variation of the Inverter firing angle. If 'a' is unity the no-load speed of the motor can be controlled from near standstill to full speed as  $|\cos \alpha|$  is varied from *almost unity* ( since the maximum value of  $\alpha$  is limited about  $165^\circ$  for safe commutation of Inverter thyristors ) to zero.

In practice the motor turns ratio  $a$  is larger than unity resulting in a lower Rotor voltage. This results in the requirement of lower value of  $\cos \alpha$  for a given lower speed and hence a *lower power factor* which is not desirable. To overcome this limitation a step-down transformer is introduced in between the supply lines and the Inverter as shown by the dotted lines with a turns ratio of  $m$ . The governing relation between the firing angle ( $\alpha$  from  $90^\circ$  to  $165^\circ$ ) and the slip then becomes:

$$s = (a/m) |\cos \alpha|$$

We know that the power factor of the converter is low at low firing angles . Hence the turns ratio 'm' of the transformer is chosen such that the drive operates always at  $\alpha = 165^\circ$  ( $|\cos \alpha| = 0.966$ ) for the required lowest speed ( highest slip  $s_{max}$  ) so that the power factor is highest.

**Torque-Speed relationship:**

Assuming the rotor resistance to be small:

The Rotor slip power is equal to the DC link power. i.e.  $s \cdot P_{ag} = E_1 \cdot I_d$

$$P_{ag} = E_1 \cdot I_d / s$$

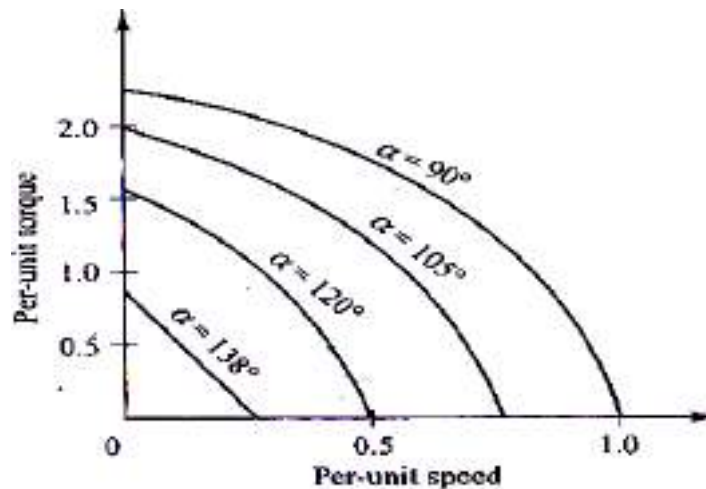
But

$$P_{ag} = T \cdot \omega_s$$

And hence

$$T = E_1 \cdot I_d / s \cdot \omega_s$$

Thus the steady state Torque is proportional to the rectified Rotor current  $I_d$  which in turn is equal to the difference between the rectified Rotor voltage and the average back e.m.f of the inverter divided by the resistance of the DC link Inductor. The inverter e.m.f is constant for a fixed firing angle and hence the Rotor slip increases linearly with load torque giving Torque-Speed characteristics similar to that of a separately excited DC motor with armature voltage control. The complete open loop Torque-Speed characteristics of the Induction motor with a **Scherbius** drive are shown in the figure below.



**Fig: open loop Torque-Speed characteristics of an Induction motor with a Scherbius drive**

**Important features of Scherbius drive:**

- Since power is fed back to the source, unlike in rotor resistance control where it is wasted in external resistors, drive has a high efficiency. The efficiency is even higher than the static voltage control for the same reason.

- Drive Input power is the difference between motor input power and the power fed back. Reactive power is the sum of the motor and inverter reactive powers. Therefore this drive has a poor power factor throughout its range of operation.

### Kramer drive:

#### Introduction:

In Kramer drive the slip power taken from the Rotor is usefully converted into mechanical power in an auxiliary motor mounted on the Induction motor shaft. The mechanical power produced by the auxiliary motor supplements the main motor power thus allowing the same power to be delivered to the load at different speeds.

In the traditional Kramer drive also the slip power is rectified by a Rotary converter (just like in a traditional Scherbius drive) and fed to a DC motor which is mechanically coupled to the main Induction motor. Thus the slip power is directly converted to mechanical power at the Induction motor shaft.

#### Static Kramer Drive:

In the Static Kramer drive the slip power is converted to DC by a Diode bridge and fed to a DC motor which is mechanically coupled to the Induction motor. Torque supplied to the motor is the sum of the torque produced by the Induction and DC motors. Speed control of the Induction motor is obtained by controlling the field current of the DC motor. A schematic diagram of this type of Static Kramer drive is shown in the figure below.

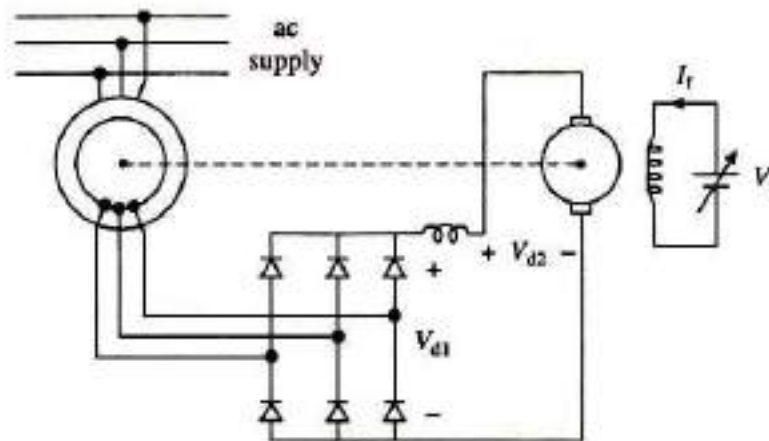


Fig: Static Kramer drive circuit

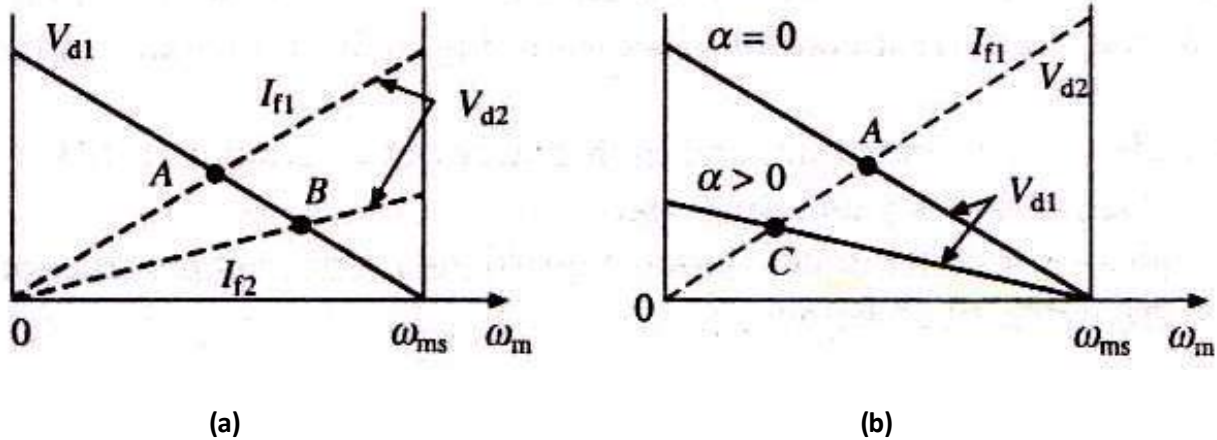
Figure (a) below shows the variations of  $V_{d1}$  and  $V_{d2}$  with speed for two values of field current. Steady state operation is obtained when  $V_{d1} = V_{d2}$  i.e at points **A** and **B** for field currents  $I_{f1}$  and  $I_{f2}$ . With this method speed control is possible from synchronous speed to around half of synchronous speed. Below



this the speed cannot be brought down. This limitation is mainly because: To increase the Speed on the lower side **Either**

- The slope of the line  **$V_{d1}$  vs. Speed** is to be decreased. For this, the maximum DC voltage  **$V_{d1}$  is to be reduced but** it is not possible from the **Diode Bridge**.
- **Or** the slope of the line  **$V_{d2}$  vs. Speed** is to be increased. i.e. the maximum value of  **$V_{d2}$**  is to be increased. This is also not possible because for a given DC motor with the maximum ratings the maximum value of speed and hence the maximum back e.m.f  **$V_{d2}$**  are fixed.

This can be clearly seen in figure (a) below.



**Fig: (a) Field control with Diode Bridge (b) Firing angle control of Thyristor Bridge with constant Motor field.**

When larger speed range is required, the above limitation is overcome (lower limit can be brought down) by replacing the **Diode Bridge with a Thyristor bridge**. With this the maximum value of  **$V_{d1}$**  can be brought down and the slope of the line  **$V_{d1}$  vs. Speed** can be reduced. This increases the lower speed limit as shown in figure (b) above. As can be seen, with this change, the speed can now be controlled almost up to standstill.

**Summary:****Important concepts and conclusions:**

- **In Rotor resistance control:**
  - For a given Load torque, the motor speed is reduced (since slip  $s$  increases) as the Rotor resistance is increased. However the no load speed remains the same with the variation of the Rotor Resistance.
  - The increase in rotor resistance does not affect the value of the maximum Torque but increases the value of Slip at which it occurs.
  - With increase in Rotor resistance the starting torque increases and the starting current reduces. Hence the Torque to current ratio improves.
- **In a Scherbius drive:** The slip  $S$  is a function of the firing angle  $\alpha$  of the Inverter as given by:

$$S = a |\cos\alpha|$$

Where  $a$  is the effective stator to rotor turns ratio of the induction motor and is given by  $a = n/m$

Where  $n$  is the actual stator to Rotor turns ratio and  $m$  is the turns ratio of the Transformer

from supply side to inverter side.

- **In a Kramer drive:**
  - The speed on the lower side is limited to about half of the synchronous speed. This is due to the fact that the maximum value of the DC out put from the Diode Bridge  $V_{d1}$  can not be brought down and maximum value of the back e.m.f of the DC motor  $V_{d2}$  cannot be increased. .
  - This problem is eliminated by the use of a fully controlled rectifier in place of the diode bridge whose maximum value of DC out put  $V_{d1}$  can be reduced by increasing the firing angle.

**UNIT-V Part-2****CONTROL OF SYNCHRONOUS MOTORS :**

- Introduction
- Separate control and self control of Synchronous Motors
- Operation of Self controlled Synchronous Motors by VSI and CSI cycloconverters
- Load commutated CSI fed Synchronous Motor:
  - Operation
  - Waveforms
  - Speed- Torque Characteristics
  - Applications
  - Advanatges
  - Numerical problems
- Closed loop operation of Synchronous motor drives (Block Diagram only)
- Variable frequency control, Cyclo converter, PWM, VFI, CSI (As per R17 to be added New )
- Summary
  - Important concepts and conclusions
  - Important formulae and equations

**Introduction:**

A synchronous motor is one in which the alternating current flows in the armature winding and DC excitation is supplied to the field winding. The armature winding is on the stator and is usually a three phase winding. The armature is identical to that of the stator in an Induction motor but there is no Induction into the Rotor. The field winding is on the rotor which is a solid forging and the slots are milled on the surface in which the DC field windings are placed.

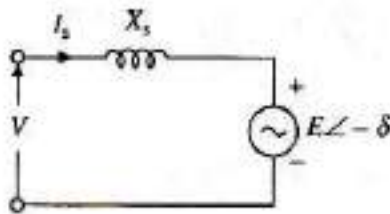
The balanced three phase armature currents establish a rotating magnetic field at the synchronous speed corresponding to the supply frequency ( $N_s = 120f/P$ ) just like in an Induction motor. If the Rotor which is supplied with a DC excitation is also made to rotate at the same synchronous speed, then the magnetic fields of stator and rotor are stationary relative to each other and a steady Torque is developed due to the tendency of the two magnetic fields to align with each other and this torque sustains the synchronous speed of the rotor. The process of initially bringing the rotor to the synchronous speed is called **Starting**.

Unlike an Induction motor Synchronous motor runs only at synchronous speed until the load Torque exceeds the **Pull out torque** which is the Torque beyond which the motor slips out of synchronism and comes to a halt.

There are several types of synchronous motors like cylindrical Rotor motors, salient pole motors, Reluctance motors, Permanent magnet motors etc. But to understand the basic control methodology we will briefly study the equivalent circuit of a cylindrical rotor motor.

**Equivalent circuit of a Synchronous Motor with cylindrical rotor :**

A simplified per phase Equivalent circuit of a Synchronous Motor with cylindrical rotor is shown in the figure below.



**Fig: Equivalent circuit of a synchronous motor with cylindrical rotor**

$X_s$  is the synchronous reactance and  $E$  is the excitation e.m.f. The power in put to the motor is given by :

$$P_{in} = 3 V I_s \cos\phi \quad \text{where } \phi \text{ is the phase angle of } I_s \text{ with respect to } V$$

Neglecting the stator loss which is small the power developed by the synchronous motor is given by :

$$P_m = 3 V I_s \cos \phi$$

$$I_s = \frac{V \angle 0 - E \angle -\delta}{jX_s} = \frac{V}{X_s} \angle -\pi/2 - \frac{E}{X_s} \angle -(\pi/2 + \delta)$$

$$I_s \cos \phi = \frac{V}{X_s} \cos(\pi/2) - \frac{E}{X_s} \cos(\pi/2 + \delta)$$

$$I_s \cos \phi = \frac{E}{X_s} \sin \delta$$

Substituting this in the equation for  $P_m$  we get

$$P_m = \frac{3VE \sin \delta}{X_s}$$

The rotating field produced by the stator moves at a synchronous speed given by :

$$\omega_{ms} = 4\pi f/P \text{ rad/sec}$$

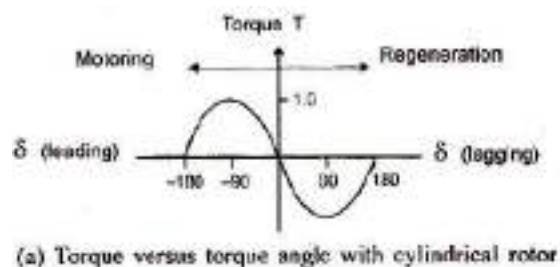
Where  $f$  is the supply frequency and  $P$  is the number of poles.

For a steady torque to be produced, rotor field must move at the same speed as the stator field. Since rotor field has the same speed as that of the Rotor the Rotor also runs at the same synchronous speed. Therefore torque is given by :

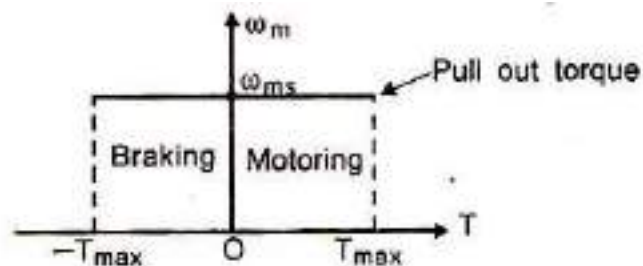
$$T = \frac{P_m}{\omega_m} = \frac{3VE}{X_s \omega_{ms}} \sin \delta$$

For a given field excitation  $E$  is constant. Therefore  $P_m$  and  $T$  are proportional to  $\sin \delta$ . The angle  $\delta$  is called **Torque (or Power) angle**.

The Pull out torque  $T_{\text{pull out}}$  (same as maximum Torque  $T_{\text{max}}$ ) is reached at  $\delta = +/- 90^\circ$ . If the load Torque exceeds  $T_{\text{pull out}}$  the motor pulls out of synchronism. The plot of developed torque vs. the torque angle  $\delta$  is shown in the figure (a) below.



The Speed-Torque curve is shown in figure (b) below. Motoring operation is obtained when  $\delta$  is positive i.e  $E$  lags behind  $V$ . Regenerative braking is obtained when  $\delta$  is negative or  $E$  leads  $V$ .



(b) Speed-torque characteristics with a fixed frequency supply

The important feature of wound field synchronous motor is that its power factor can be controlled by varying the field current which in turn varies the excitation voltage  $E$ . The phasor diagrams of a synchronous motor for a given developed power are shown in the figure below. As can be seen when the field excitation is small the motor operates with a lagging power factor. The power factor can be made unity or leading by increasing the field excitation.

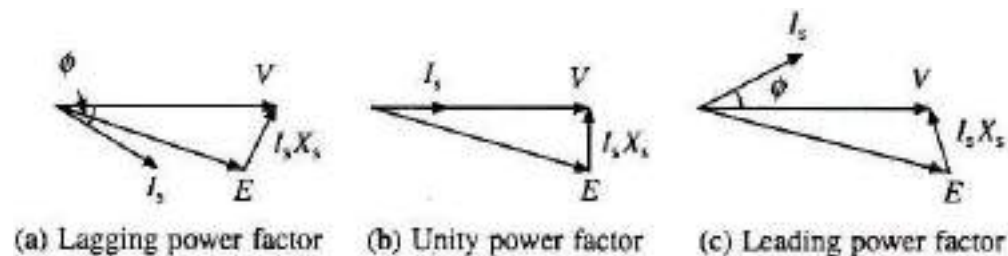


Fig: Variation of power factor with field excitation

#### Speed control of synchronous motors:

In synchronous motors also, in steady state, the speed is directly proportional to the supply frequency and the control methodology is same like in Induction motors. Constant flux operation below base speed is achieved by constant  $V/f$  control. Above base speed once the rated voltage is reached, the terminal voltage is kept constant and frequency is increased. The pull out Torque ( $T_{max}$ ) is constant during the constant flux operation where as it decreases with increase in frequency for higher speeds.

Unlike an Induction motor the synchronous motor either runs at the synchronous speed or it does not run at all. Hence the variable frequency control adopts any of the following two methods.

1. True Synchronous Mode or Separate Control Mode

## 2. Self control Mode

### Separate Control Mode:

This is an open loop control mode in which the stator supply frequency is controlled from an Independent oscillator. Hence the frequency is gradually increased from its initial value to the final desired value so that the difference between the synchronous and rotor speed is always very small. This enables the rotor to track the changes in synchronous speed and catch up with out pulling out. When the desired synchronous speed is reached, the rotor pulls into step, after hunting oscillations. This method can be used for smooth starting and regenerative braking. This method is best suited for multiple synchronous reluctance or Permanent magnet (PM) motor drives where close speed tracking is essential among a number of machines in applications such as fiber spinning mills, paper and textile mills where accurate speed tracking is required.

The block diagram of such an open loop control system using this separate control method for multiple synchronous motors is shown in the figure below.

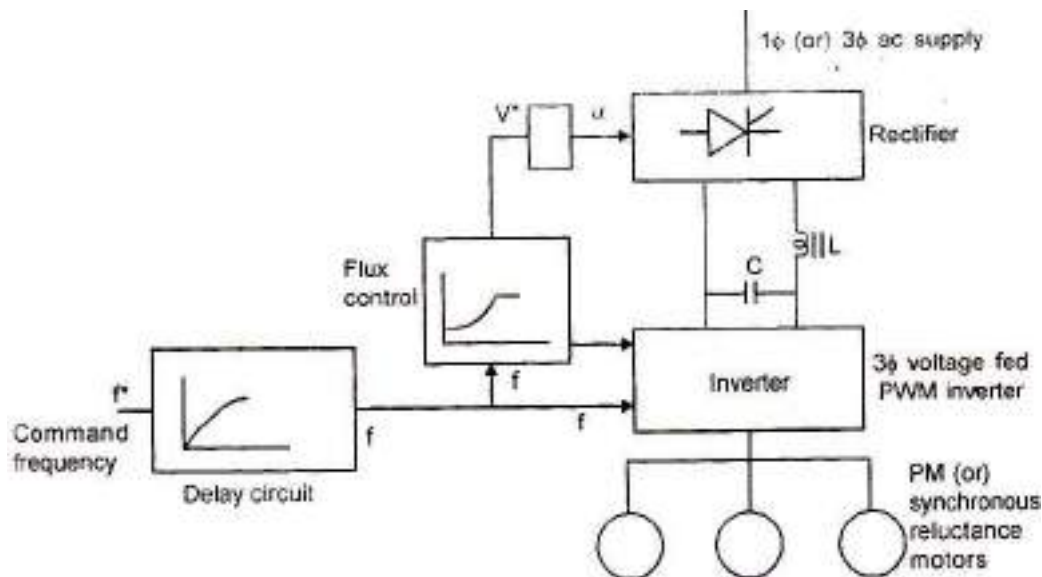


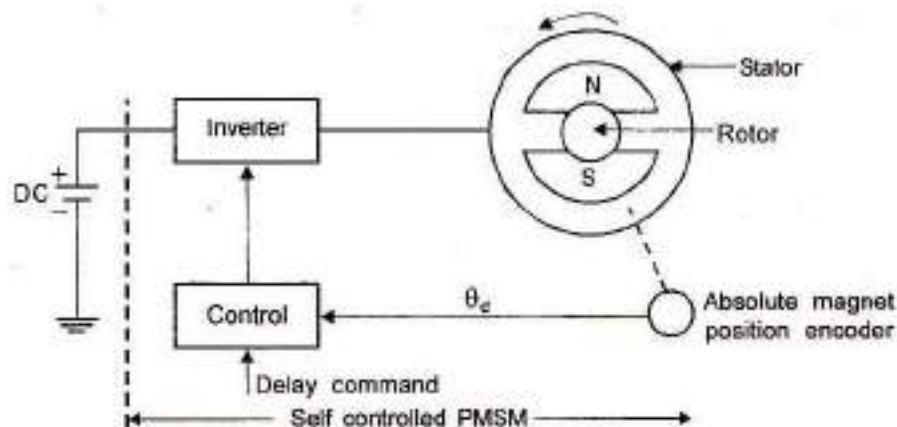
Fig: Open loop speed control of multiple PM synchronous motors.

Here all the machines are connected to the same Inverter and they move in response to the command frequency  $f^*$  at the input to the Ramp/delay circuit. The Input speed command is given through a ramp generator with a finite delay to ensure that the rotor gradually picks up speed and pulls into synchronism with the stator magnetic field and settles at the final synchronous speed. The frequency command  $f^*$  after passing through the ramp/delay circuit generates the required  $V$  and  $f$  control signals just like in a VSI with a PWM Inverter as shown in the figure. The  $V$  control is applied to the DC converter through a flux control block so as to generate the required Voltage to generate a constant flux with varying frequency. The Rectifier output then gets applied to the PWM inverter through  $L$  &  $C$  filter as required for a VSI type drive. The frequency command is directly applied to the PWM inverter. The synchronous motor can be built with damper winding to prevent oscillations.

### Self controlled mode:

In this method the supply frequency is changed such that the synchronous speed is same as that of the rotor speed. Hence motor cannot pull-out out of step and hunting oscillations are eliminated. For such a mode of operation the motor does not require a damper winding.

The basic block diagram of a **self control system** for a permanent magnet (PM) synchronous motor is shown in the figure below.



Here the frequency and phase of the control signal required to generate the required input to the synchronous motor is produced by comparing the output of an absolute position sensor mounted on the shaft of the synchronous motor thus giving it the self control characteristic. Here the pulse train from the position sensor can be delayed by an external command as shown in the figure.

In this kind of control the machine behavior is decided by the torque angle and voltage/current. Such a motor can be considered as a DC motor with its commutator replaced by a fully controlled converter connected to the stator. Such a self controlled motor has the properties of a DC motor both under steady state and dynamic conditions. Hence it is called a Commutator Less Motor (CLM). These motors have better stability performance.



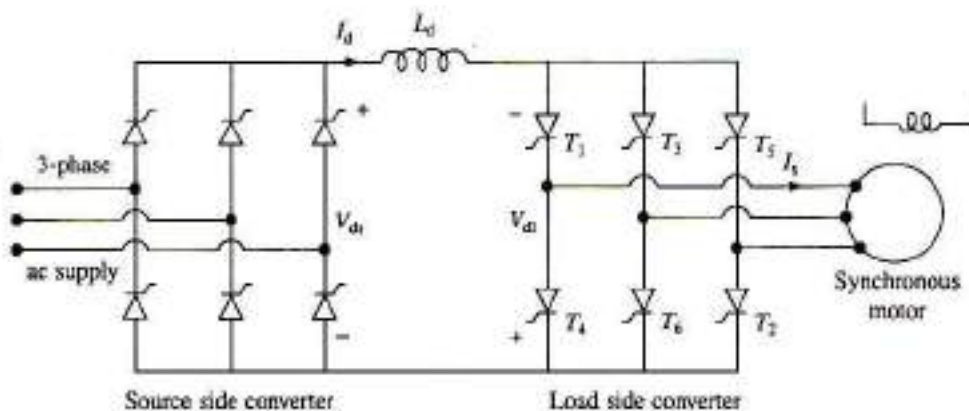
Alternately the firing pulses for the inverter can be obtained from the phase angle of the stator voltages in which case the rotor position sensor can be dispensed with. When synchronous motors are over excited (field current is large) they will work with a leading power factor and can supply the reactive power required for commutation of thyristors. In such a case the induced voltages in the synchronous motor provide the required voltages for commutation of the thyristors in the inverter just as a line commutated Inverter works.

Here the firing angles are synchronized with the motor induced voltages and hence they serve both for control as well as commutation. Hence the frequency of the inverter will be same as that of the motor induced voltages. This type of inverters are called load commutated Inverters (LCI). Hence the commutation is simple due to the absence of diodes, capacitors and auxiliary thyristors.

But this natural commutation is not possible at low speeds upto 10% of base speed as the motor voltages are not sufficient to provide satisfactory commutation. At that time forced commutation must be employed.

#### Load commutated CSI fed synchronous motor:

The circuit diagram of a self controlled synchronous motor drive employing a load commutated thyristor Inverter is shown in the figure below. This drive consists of two parts: Source side converter and load side converter.



**Fig: Self controlled Synchronous Motor Drive employing Load Commutated Inverter**

The source side converter is a 3 phase 6 pulse line commutated fully controlled converter. When the firing angle range is  $0^\circ < \alpha_s < 90^\circ$  the converter acts as a line commutated fully controlled rectifier. During this mode the output voltage  $V_{d_s}$  and output current  $I_{d_s}$  are both positive.

When the firing angle range is  $90^\circ < \alpha_s < 180^\circ$  the converter acts as a line commutated fully controlled inverter. During this mode the output voltage  $V_{d_s}$  is negative and output current  $I_{d_s}$  is positive.

When the synchronous motor operates at a leading power factor, thyristors of the load side converter are commutated by the motor induced voltages just like the thyristors in a line commutated converter are commutated by the supply voltages. This is called Load commutation (here load is synchronous motor). Firing (triggering) angles are referred to the induced voltages just like the triggering angles in a line commutated inverter are referred to the supply voltages.

When the firing angle range is  $0^\circ < \alpha_1 < 90^\circ$  the **load side** converter acts as a line commutated fully controlled rectifier. During this mode the output voltage  $V_{d1}$  and output current  $I_d$  are both positive.

When the firing angle range is  $90^\circ < \alpha_1 < 180^\circ$  the **load side** converter acts as a line commutated fully controlled inverter. During this mode the output voltage  $V_{d1}$  is negative and current  $I_d$  is positive.

For  $0^\circ < \alpha_s < 90^\circ$ ,  $90^\circ < \alpha_1 < 180^\circ$  and with  $V_{ds} > V_{d1}$  the source side converter acts like a line commutated Rectifier and load side Converter acts like a line commutated Converter causing power to flow from the source to the motor thus giving motoring operation.

When the firing angles are changed such that  $90^\circ < \alpha_s < 180^\circ$  and  $0^\circ < \alpha_1 < 90^\circ$  the load side converter acts like a line commutated Rectifier and source side Converter acts like a line commutated Inverter causing power to flow from the motor to the source thus giving regenerative braking operation.

The magnitude of Torque depends on  $(V_{ds} - V_{d1})$ . The motor speed can be controlled by control of line side converter firing angles.

When working as an Inverter, the firing angle has to be less than  $180^\circ$  to take care of commutation overlap and turn off of thyristors. It is common to define a commutation lead angle for load side converter as

$$\beta_1 = 180^\circ - \alpha_1$$

If commutation overlap is ignored, the input AC current of the converter will lag behind the input AC voltage by an angle  $\alpha_1$ . Since motor input current has an opposite phase to converter input current, the motor current will lead its terminal voltage by an angle  $\beta_1$ . Therefore the motor operates at a leading power factor.

Lower the value of  $\beta_1$ , higher the motor power factor and lower the Inverter rating. The commutation overlap for the load side converter depends on the sub transient Inductance of the motor. The motor is provided with a damper winding in order to reduce the sub transient Inductance. This allows operation with a substantially lower value of  $\beta_1$ . The damper winding does not play its conventional role of starting the motor as an Induction motor and to damp oscillations, because rotor and rotating field speeds are always the same as explained later. In a simple control scheme, the drive is operated at a fixed value of commutation lead angle  $\beta_{1c}$  for the load side converter working as an Inverter and at  $\beta_1 = 180^\circ$  (or  $\alpha_1 = 0^\circ$ ) when working as a rectifier. When good power factor is required to minimize converter rating, the load side converter when working as an inverter is operated with **constant margin angle control**.

# What is overlap angel of a thyristor?

In: [Technology](#) [[Edit categories](#)]

Answer:

**Overlap angle of a rectifier ( $\mu$ ):** The commutation process in a practical rectifier is not instantaneous. During the period of commutation, both the incoming and the outgoing devices conduct current simultaneously. This period, expressed in radians, is called the overlap angle " $\mu$ " of a rectifier. It is easily verified that  $\alpha + \mu + \gamma = \pi$  radian.

$\alpha$ = Firing angel

$\mu$ =Overlap angel

$\gamma$  =extinction angel

Back to the commutation overlap angle: If you had an entirely inductive circuit, commutation overlap would be 90 degrees, and the diode would be in forward conduction for approximately 90 degrees after the applied voltage polarity goes negative across the diode. As the L/R ratio decreases, the commutation angle decreases

What is meant by margin angle of commutation?

The difference between the lead angle of firing and the overlap angle is called the margin angle of commutation. If this angle of the thyristor, commutation failure occurs. Safe commutation is assured if this angle has a minimum value equal to the turn off angle of the thyristor.

If commutation overlap of the thyristor under commutation is denoted by  $\mu$ , then the duration for which the thyristor under commutation is subjected to reverse bias after the current through that has fallen to zero is given by

$$\gamma = \beta_1 - \mu$$

For successful commutation of thyristor

$$\gamma > \omega \cdot t_q$$

where  $t_q$  is the turn off time of the thyristors and  $\omega$  the frequency of motor voltage in radians/sec. Since  $\mu$  is proportional to  $I_d$ , for a given  $I_d$ ,  $\beta_1$  can be calculated such that the thyristor under commutation is reverse biased for a duration of  $\gamma_{min}$  which is just enough for its commutation. This in turn minimizes the  $\beta_1$  and maximizes the motor power factor. Since  $\gamma$  is kept constant at its minimum value  $\gamma_{min}$ , the control scheme is called **constant angle margin control**.

---

The DC link inductor  $L_d$  reduces the ripple in the DC link current  $I_d$  and prevents the two converters from interfering with each other's operation. Because of the presence of the Inductor in the DC link, the load side converter when working as an inverter behaves essentially as a current source Inverter of Induction motor drives except that thyristor commutation is now performed by motor induced voltages. Consequently, the motor phase current has six step waveform like in the earlier CSI. Because of the DC current through  $L_d$ , the AC input current of source side converter also has a six step current waveform.

The DC line current  $I_d$  flows through the motor phase for  $120^\circ$  in each half cycle. Fundamental component of motor phase current  $I_s$  has the following relationship with  $I_d$ .

$$I_s = (\sqrt{6/\pi}) \cdot I_d.$$

For motor operation in the self controlled mode, rotating **stator** field speed should be same as the rotor speed. This condition is realized by making frequency of the load side converter output voltage equal to the frequency of voltage induced in the armature. Firing pulses are therefore generated either by comparison of motor terminal voltages (as induced voltages are not directly accessible) or by the rotor position sensors which are stationary and suitably aligned with the Armature winding thus ensuring proper self control. The frequency of induced voltages depends on the speed of rotor (or rotor field) and their phase depends on the location of rotor poles with respect to the armature windings. Hence, signals generated by the rotor position sensors have the same frequency as that of the induced voltages and have a definite phase with respect to the induced voltages. Load side converter thyristors are fired in the sequence of their numbers with  $60^\circ$  interval. Therefore for the control of load side converter thyristors in all six rotor angular positions are required to be detected per cycle of the induced voltage. Hall- effect sensors can detect the magnitude and direction of a magnetic field. Hence, to detect the six rotor position they are mounted at  $60^\circ$  electrical interval and aligned suitably with armature winding.

As stated earlier, the load side converter and the current source Inverter used in induction motor drives perform essentially the same function. The only difference between the two is that while the former uses the load commutation, the later uses forced commutation. Load commutation has a number of advantages over forced commutation:

1. It does not require commutation circuits.
2. Frequency of operation can be higher and
3. It can operate at power levels beyond the capability of forced commutation.

Load side converter performs some what similar functions as a commutator in a DC machine. The load side converter and synchronous motor combination functions similar to a DC motor. First, it is fed from a DC supply and secondly like a DC motor the stator and the rotor fields remain stationary with respect to each other at all speeds. Consequently the drive consisting of load side converter and synchronous motor is known as **Commutator Less DC motor**.

At low speeds, motor induced e.m.fs will be insufficient to commutate the thyristors of load side converter, therefore, at start and speeds below 10% of base speed ,the commutation of load side

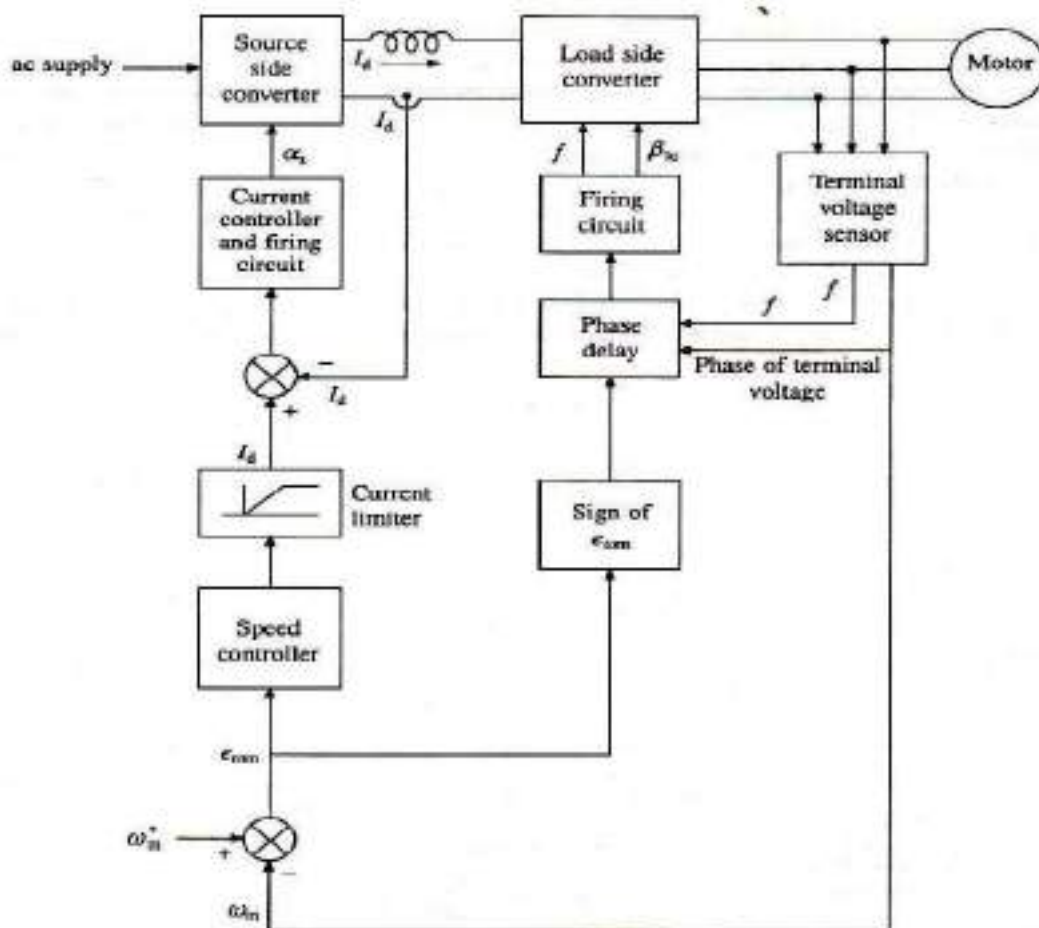
---

converter thyristors is done by forcing the current through conducting thyristors to Zero. This is realized by making source side converter to work as an inverter each time load side converter thyristors are to be turned off.

For example thyristors T1 and T2 are to conduct together for  $60^\circ$  electrical. After  $60^\circ$ , source side converter will be made to work as an inverter, which will reverse  $V_{ds}$  and turn off thyristors T1 and T2. Now the source side converter operation is brought back to rectification mode and gate pulses are released to T2 and T3 to turn them ON and make them conduct together for next  $60^\circ$  electrical. Since frequency of operation of load side converter at low motor speeds is very low compared to source frequency, such an operation can be realized. This operation of the Inverter can be termed as **Pulsed mode**. This mode of operation requires rotor position sensors. Therefore, even when the normal operation above 10% of base speed is implemented by sensing motor's terminal voltages, rotor position sensors will be needed to realize pulsed mode.

### Closed loop operation of Synchronous drives:

A closed loop speed control scheme is shown in the figure below.



It employs outer speed control loop and inner current control loop with a limiter like in a DC motor speed control system. The terminal voltage sensors generate reference pulses of same frequency as the motor-induced voltages. The phase delay circuit shifts the reference pulses suitably to obtain control at a constant commutation lead angle  $\beta_{ic}$ . Depending on the sign of speed error,  $\beta_{ic}$  is set to provide motoring or braking operation. Speed  $\omega_m$  can be sensed either from the terminal voltage sensor or from a separate tachometer. An increase in reference speed  $\omega_m$  produces a positive speed error.  $\beta_{ic}$  value is then set for motoring operation. The speed controller and the current limiter set the DC link current reference at the maximum permissible value. The motor accelerates fast. When close to the desired speed the current limiter desaturates and the drive settles at the desired speed and at a DC link current which balances motor and load torques. Similarly a reduction in reference speed produces a negative speed error. This sets  $\beta_{ic}$  for regenerative braking operation (i.e.  $180^\circ$ ) and the motor decelerates. When speed error changes sign  $\beta_{ic}$  value is set for motoring operation and the drive settles at the desired speed.

At very high power levels harmonics generated at the source and motor terminals require special attention. The source harmonics are reduced by using a 12 pulse converter.

**Advantages:**

- High efficiency, four quadrant operation with regenerative braking, high power ratings (upto 100Mw) and ability to run at high speeds (6000 RPM) are some important advantages of this drive.

**Applications:**

- Wound field Synchronous motors are used in large power drives.
- Permanent motor synchronous motors are used in medium power drives.
- Some prominent applications are high speed and high power drives for compressors, blowers, fans, pumps, conveyors, steel rolling mills, main line traction, ship propulsion and aircraft test facilities.

